

SERVICE MANUAL

SERVICE MANUAL SECTION

**3200, 4100, 4300, 4400, 7300, 7400, 7500, 7600, 7700, 8500, RXT
Models Built March 1, 2007 to March 18, 2008 — ELECTRICAL CIRCUIT
DIAGRAMS**

Model: 3200

Start Date: 03/01/2007 End Date: 03/18/2008

Model: 4100

Start Date: 03/01/2007 End Date: 03/18/2008

Model: 4300

Start Date: 03/01/2007 End Date: 03/18/2008

Model: 4400

Start Date: 03/01/2007 End Date: 03/18/2008

Model: 7300

Start Date: 03/01/2007 End Date: 03/18/2008

Model: 7400

Start Date: 03/01/2007 End Date: 03/18/2008

Model: 7500

Start Date: 03/01/2007 End Date: 03/18/2008

Model: 7600

Start Date: 03/01/2007 End Date: 03/18/2008

Model: 7700

Start Date: 03/01/2007 End Date: 03/18/2008

Model: 8500

Start Date: 03/01/2007 End Date: 03/18/2008

Model: 8600

Start Date: 03/01/2007 End Date: 03/18/2008

Model: RXT

Start Date: 03/01/2007 End Date: 03/18/2008

S08322

03/25/2009

Table of Contents

1. TABLE OF CONTENTS (CHAPTER 1).....	1
2. INSTRUCTIONS AND CHARTS (CHAPTER 2).....	1
2.1. ABBREVIATIONS, P. 1.....	1
2.2. ACRONYMS, P. 2.....	2
2.3. CIRCUIT DIAGRAM INSTRUCTIONS, P. 3.....	3
2.4. CIRCUIT NUMBER IDENTIFICATION AND COLOR, P. 4.....	4
2.5. CIRCUIT NUMBER IDENTIFICATION AND COLOR, P. 5.....	5
2.6. CIRCUIT NUMBER IDENTIFICATION AND COLOR, P. 6.....	6
2.7. LAMP BULB CHART, P. 7.....	7
2.8. RELAY FUNCTION AND WIRING GUIDE, P. 8.....	8
2.9. SCHEMATIC SYMBOL CHART, P. 9.....	9
2.10. SCHEMATIC SYMBOL CHART, P. 10.....	10
2.11. SCHEMATIC SYMBOL CHART, P. 11.....	11
2.12. SCHEMATIC SYMBOL CHART, P.12.....	12
3. 12 VOLT POWER DISTRIBUTION, GROUNDS, DATA BUS AND ELECTRICAL SYSTEM CONTROLLER (CHAPTER 3).....	13
3.1. BATTERY FEED, P. 1.....	13
3.2. BATTERY FEED, P. 2.....	14
3.3. BATTERY FEED, P. 3.....	15
3.4. ACCESSORY FEED, P. 4.....	16
3.5. IGNITION FEED — STANDARD, THEFT DETERRENT, REMOTE START/STOP, P. 5.....	17
3.6. IGNITION FEED RELAY 1, P. 6.....	18
3.7. IGNITION FEED RELAY 2, P. 7.....	19
3.8. IGNITION FEED RELAY 3, P. 8.....	20
3.9. J1708 DATA LINK — PUBLIC EFFECTS, P. 9.....	21
3.10. J1708 DATA LINK — PUBLIC EFFECTS, P. 10.....	22
3.11. J1708 DATA LINK — PRIVATE WITH POWER WINDOW AND LOCK, P. 11.....	23
3.12. J1939 DATA LINK, P. 12.....	24
3.13. J1939 DATA LINK WITH OPTIONS, P. 13.....	25
3.14. J1939 DATA LINK WITH OPTIONS, P. 14.....	26
3.15. J1939 DATA LINK — ISM 2007 ENGINE, P. 15.....	27
3.16. J1939 DATA LINK — I6 2007 ENGINE, P. 16.....	28
3.17. J1939 DATA LINK — C11/C13 2007 ENGINE, P. 17.....	29
3.18. GROUND — IP, P. 18.....	30
3.19. GROUND — IP, P. 19.....	31
3.20. GROUND — IP, P. 20.....	32
3.21. GROUND — IP, P. 21.....	33
3.22. ENGINE GROUND, P. 22.....	34
3.23. ENGINE GROUND, P. 23.....	35
3.24. GROUND — CHASSIS, P. 24.....	36
3.25. GROUND — CHASSIS WITH HEAVY DUTY DIESEL, P. 25.....	37
3.26. GROUND — CHASSIS, P. 26.....	38
3.27. ZERO VOLT REFERENCE, P. 27.....	39
3.28. ZERO VOLT REFERENCE, P. 28.....	40
3.29. GROUND — CHASSIS, P. 29.....	41

3.30. J1939 DATA LINK WITH V8 ENGINE, P. 30.....	42
4. CAB ACCESSORIES (CHAPTER 4).....	43
4.1. CIGAR LIGHTER AND POWER FEED, P. 1.....	43
4.2. CIGAR LIGHTER AND POWER FEED, P. 2.....	44
4.3. CB POWER RADIO, P. 3.....	45
4.4. COMPASS AND TEMPERATURE DISPLAY, P. 4.....	46
4.5. FRONT DOOR WINDOWS AND LOCKS (POWER), P. 5.....	47
4.6. FRONT DOOR WINDOWS AND LOCKS (POWER) FOR CREW, P. 6.....	48
4.7. HORN, ELECTRIC AND AIR, P. 7.....	49
4.8. HORN, ELECTRIC AND AIR, P. 8.....	50
4.9. MIRRORS (HEATED, LIGHTED AND POWER), P. 9.....	51
4.10. MIRRORS (HEATED, LIGHTED AND POWER), P. 9A.....	52
4.11. DUAL HEATED MOTORIZED MIRRORS WITH HEATED WINDSHIELD, P. 9B.....	53
4.12. RADIO (ENTERTAINMENT), SPEAKERS WITH 12 WAY CONN, P. 10.....	54
4.13. RADIO (ENTERTAINMENT), SPEAKERS WITH 16 WAY CONN, P. 11.....	55
4.14. 2-WAY RADIO, P. 12.....	56
4.15. WINDSHIELD WIPER, P. 13.....	57
4.16. WASHER PUMP, P. 14.....	58
4.17. SWITCH PACK OPTIONAL GAUGE PACK, P. 15.....	59
4.18. ROOF AUXILIARY LOAD, P. 16.....	60
4.19. SATELLITE COMMUNICATION — QUALCOMM IMCT, P. 17.....	61
4.20. SATELLITE COMMUNICATION — TRIPMASTER, P. 18.....	62
4.21. COMPUTER PREWIRED — XATA SYSTEM, P. 19.....	63
4.22. CADEC GPS SYSTEM, P. 20.....	64
4.23. SATELLITE COMMUNICATION — MOBILEMAX, P. 21.....	65
4.24. SELF CONTAINED AIR SEAT, P. 22.....	66
4.25. HEATED SEATS, P. 23.....	67
4.26. TELEMATICS SYSTEM, P. 24.....	68
4.27. EATON VORAD COLLISION AVOIDANCE SYSTEM, P. 25.....	69
4.28. EATON VORAD COLLISION AVOIDANCE SYSTEM, P. 26.....	70
4.29. DRIVER DISPLAY, P. 27.....	71
4.30. BACK-UP CAMERA, P. 28.....	72
4.31. SATELLITE COMMUNICATION — QUALCOMM MCT, P. 29.....	73
4.32. SATELLITE COMMUNICATION — QUALCOMM MCT WITH MVPC KEYBOARD, P. 30.....	74
4.33. SATELLITE COMMUNICATION — QUALCOMM TMCT, P. 31.....	75
4.34. SATELLITE COMMUNICATION — QUALCOMM TMCT, P. 32.....	76
4.35. AIR SHIELD LIGHT, P. 33.....	77
5. 12V CHARGING + CRANKING SYSTEM (CHAPTER 5).....	78
5.1. I6 / V8 ENGINES WITH MANUAL TRANSMISSION, P. 1.....	78
5.2. CAT — CUMMINS ENGINES WITH MANUAL TRANSMISSION, P. 2.....	79
5.3. I6 / V8 ENGINES WITH ALLISON TRANSMISSION, P. 3.....	80
5.4. CAT — CUMMINS ENGINES WITH ALLISON TRANSMISSION, P. 4.....	81
5.5. I6 ENGINE WITH AUTOSHIFT, ULTRASHIFT AND EATON HYBRID TRANSMISSION, P. 5.....	82
5.6. CAT — CUMMINS ENGINES WITH AUTOSHIFT AND ULTRASHIFT TRANSMISSION, P. 6.....	83
5.7. I6 POWER PACK, P. 7.....	84
5.8. ROCKER START, P. 8.....	85
6. FANS AND ENGINE ACCESSORIES (CHAPTER 6).....	86
6.1. FAN WIRING, I6 / V8 2007 ENGINES, P. 1.....	86
6.2. FAN WIRING, ISM, C11-C13 2007 ENGINES, P. 2.....	87
6.3. STARTING AID — ETHER START, P. 3.....	88

6.4. SNOW VALVE, P. 4.....	89
7. ELECTRONIC ENGINES (CHAPTER 7).....	90
7.1. ELECTRONIC ENGINE CONTROLS, CAT ENGINES, P. 1.....	90
7.2. ELECTRONIC ENGINE CONTROLS, CAT ENGINES, P. 2.....	91
7.3. ENGINE BODY BUILDER — REMOTE ENGINE CONTROL (CAT/IBBE ENGINE), P. 3.....	92
7.4. ELECTRONIC ENGINE CONTROLS, ISM ENGINES, P. 4.....	93
7.5. ELECTRONIC ENGINE CONTROLS, ISM ENGINES, P. 5.....	94
7.6. ELECTRONIC ENGINE CONTROLS, ISM ENGINES, P. 6.....	95
7.7. ELECTRONIC ENGINE CONTROLS, I6 ENGINES, P. 7.....	96
7.8. ELECTRONIC ENGINE CONTROLS, I6 ENGINES, P. 8.....	97
7.9. ELECTRONIC ENGINE CONTROLS, I6 ENGINES, P. 9.....	98
7.10. ELECTRONIC ENGINE CONTROLS, I6 ENGINES, P. 10.....	99
7.11. ELECTRONIC ENGINE CONTROLS, I6 ENGINES, P. 11.....	100
7.12. ELECTRONIC ENGINE CONTROLS — V8 ENGINES, P. 12.....	101
7.13. ELECTRONIC ENGINE CONTROLS — V8 ENGINES, P. 13.....	102
7.14. ELECTRONIC ENGINE CONTROLS — V8 ENGINES, P. 14.....	103
7.15. CRUISE CONTROL, P. 15.....	104
8. GAUGES WITH AND WITHOUT INTERNAL WARNING LIGHT (CHAPTER 8).....	105
8.1. IP/GAUGES, P. 1.....	105
8.2. WARNING LIGHT LIST, P. 2.....	106
8.3. WARNING LIGHTS CONTROLLED BY ENGINE, TRANSMISSION, ABS CONTROLLER, P. 3.....	107
8.4. ENGINE OIL PRESSURE AND TEMP, SPEEDOMETER, TACHOMETER, VOLTMETER AND WATER TEMP GAUGE CIRCUITS, P. 4.....	108
8.5. IP/GAUGES AND WARNING LIGHTS — GAUGE CLUSTER, P. 5.....	109
8.6. AIR PRESSURE INPUT CIRCUIT, P. 6.....	110
8.7. AXLE TEMPERATURE, GAUGE INPUT CIRCUIT, P. 7.....	111
8.8. FUEL GAUGE CIRCUITRY (SINGLE TANK), P. 8.....	112
8.9. DIFFERENTIAL LOCK WARNING LAMPS, P. 9.....	113
8.10. AIR PARK BRAKE AND MANUAL TRANSMISSION OIL TEMP GAUGE, P. 10.....	114
8.11. GAUGES AND WARNING LIGHTS — AMMETER, P. 11.....	115
8.12. ENGINE OIL TEMPERATURE GAUGE WITH CATERPILLAR, P. 12.....	116
8.13. FRONT AXLE ENGAGEMENT LAMP, P. 13.....	117
8.14. WARNING LIGHTS — OPTIONAL, P. 14.....	118
8.15. WARNING LIGHTS — OPTIONAL, P. 15.....	119
8.16. LOAD MONITORING, P. 16.....	120
9. LIGHTS (CHAPTER 9).....	121
9.1. BACKUP LIGHTS N/ ALLISON TRANSMISSION, P. 1.....	121
9.2. BACKUP LIGHTS W/ ALLISON TRANSMISSION, P. 2.....	122
9.3. LIGHT SYSTEMS — CLEARANCE, MARKER, PARK, TAIL, TURN AND STOP LIGHTS, P. 3.....	123
9.4. LIGHT SYSTEMS — CLEARANCE, MARKER, PARK, TAIL, TURN AND STOP LIGHTS (CONT.), P. 4.....	124
9.5. LIGHT SYSTEMS — CLEARANCE, MARKER, PARK, TAIL, TURN AND STOP LIGHTS (CONT.), P. 5.....	125
9.6. LIGHT SYSTEMS — CLEARANCE, MARKER, PARK, TAIL, TURN AND STOP LIGHTS (CONT.), P. 6.....	126
9.7. LIGHT SYSTEMS — TURN SIGNAL AND STOP SWITCHES, P. 7.....	127
9.8. DOME LIGHT, MAP LIGHT, P. 8.....	128
9.9. DOME LIGHT, MAP LIGHT (CONT.), P. 9.....	129

9.10. DOME LIGHT, MAP LIGHT (CONT.), P. 10.....	130
9.11. FOG LIGHT AND WORK LIGHT, P. 11.....	131
9.12. HEADLIGHTS, P. 12.....	132
9.13. AUX. HEADLIGHTS, SNOW PLOW LIGHTS, P. 13.....	133
9.14. AUX. HEADLIGHTS, SNOW PLOW LIGHTS (CONT), P. 14.....	134
9.15. PANEL LIGHTS, P. 15.....	135
10. CHASSIS ACCESSORIES (CHAPTER 10).....	136
10.1. ABS — BENDIX AIR, P. 1.....	136
10.2. ABS — BENDIX AIR, P. 2.....	137
10.3. ABS — BENDIX AIR, P. 3.....	138
10.4. ABS — WABCO AIR, P. 4.....	139
10.5. ABS — WABCO AIR, P. 5.....	140
10.6. WABCO FULL POWER BRAKES, P. 6.....	141
10.7. WABCO FULL POWER BRAKES, P. 7.....	142
10.8. WABCO FULL POWER BRAKES, P. 8.....	143
10.9. BODY BUILDER AND TRAILER — TURN, MARKERS AND STOP, P. 9.....	144
10.10. BODY BUILDER AND TRAILER — TURN, MARKERS AND STOP, P. 10.....	145
10.11. TRAILER SOCKET — SOC AND EOF, P. 11.....	146
10.12. BODY BUILDER AND TRAILER SOCKET — SOC AND EOF, P. 12.....	147
10.13. BODY BUILDER CONNECTIONS, P. 13.....	148
10.14. REMOTE START / STOP, P. 14.....	149
10.15. AUX TRAILER CIRCUIT, P. 15.....	150
10.16. TWO SPEED AXLE SWITCH, P. 16.....	151
10.17. AIR SOLENOID, P. 17.....	152
10.18. AIR SOLENOID, P. 18.....	153
10.19. REMOTE POWER UNITS, SOLENOID PACKS, REMOTE ENGINE SPEED CONTROLLER, P. 19.....	154
10.20. BLANK PAGE, P. 20.....	155
10.21. AUX AND POWER SOURCE, P. 21.....	156
10.22. AIR DRYER AND HEATED DRAIN VALVE, P. 22.....	157
10.23. FUEL / WATER SEPARATOR, P. 23.....	158
10.24. ELECTRIC TRAILER BRAKE, P. 24.....	159
10.25. LECTRASHIFT ACCOMMODATION, P. 25.....	160
10.26. HOUR METER — PTO, P. 26.....	161
10.27. AUX INPUTS AND DRIVERS, P. 27.....	162
10.28. FUEL TRANSFER PUMP, P. 28.....	163
10.29. BLANK PAGE, P. 29.....	164
10.30. TELEMATICS AWARE — BODY BUILDER, P. 30.....	165
10.31. PRESSURE SWITCH, P. 31.....	166
10.32. LIFT GATE, P. 32.....	167
10.33. WHEELCHAIR LIFT INTERLOCK, P. 33.....	168
10.34. LIFT AXLE WITH CONTROLS FOR ONE LIFT AXLE, P. 34.....	169
10.35. LIFT AXLE (NON-STEERABLE), P. 35.....	170
10.36. LIFT AXLE (STEERABLE), P. 36.....	171
10.37. LIFT AXLES, P. 37.....	172
10.38. LIFT AXLES, P. 37A.....	173
10.39. ABS — BENDIX AIR 6S/6M, P. 38.....	174
10.40. ABS — BENDIX AIR 6S/6M, P. 39.....	175
10.41. LIFT AXLE WITH CONTROLS FOR TWO LIFT AXLES, P. 40.....	176
10.42. LIFT AXLE WITH CONTROLS FOR THREE LIFT AXLES, P. 41.....	177
10.43. LIFT AXLE WITH CONTROLS FOR FOUR LIFT AXLES, P. 42.....	178
10.44. ABS ESP / RSP, P. 43.....	179

10.45. ABS ESP / RSP, P. 44.....	180
11. TRANSMISSIONS (CHAPTER 11).....	181
11.1. ALLISON GEN 4 1/2000 TRANSMISSION WITH I6 AND WITH V8 ENGINE, P. 1.....	181
11.2. ALLISON GEN 4 1/2000 TRANSMISSION WITH I6 AND WITH V8 ENGINE, P. 2.....	182
11.3. ALLISON GEN 4 1/2000 TRANSMISSION W/ I6, CAT, ISM ENGINE, P. 3.....	183
11.4. TRANSMISSION, ALLISON MD WITH I6 AND WITH V8 ENGINE, P. 4.....	184
11.5. TRANSMISSION, ALLISON MD 3/4000 WITH I6 AND WITH V8 ENGINE, P. 5.....	185
11.6. TRANSMISSION, ALLISON MD/HD (WTEC) WITH I6 AND WITH V8 ENGINE, P. 6.....	186
11.7. TRANSMISSION, ALLISON MD/HD (WTEC) WITH I6 AND WITH V8 ENGINE (CONT.), P. 7.....	187
11.8. TRANSMISSION, ALLISON MD (WTEC), P. 8.....	188
11.9. TRANSMISSION, ALLISON MD (WTEC), P. 8A.....	189
11.10. TRANSMISSION, ALLISON MD (WTEC) (ISM ENGINE), P. 9.....	190
11.11. TRANSMISSION, ALLISON MD (WTEC) (ISM ENGINE), P. 10.....	191
11.12. EATON AUTOSHIFT TRANSMISSION W/ I6 ENGINE, P. 11.....	192
11.13. EATON AUTOSHIFT TRANSMISSION, P. 12.....	193
11.14. TRANSMISSION ALLISON MD (WTEC) W/ CAT ENGINE, P. 13.....	194
11.15. TRANSMISSION ALLISON MD (WTEC) W/ CAT ENGINE, P. 14.....	195
11.16. TRANSMISSION RETARDER CONTROLS WIRING WITH MD TRANSMISSION HARD WIRED EFFECTS, P. 15.....	196
11.17. EATON AUTO AND ULTRASHIFT GEN 3 TRANSMISSION W/ CAT AND W/ ISM ENGINE, P. 16.....	197
11.18. ALLISON TRANSMISSION 3/4000 GEN 4 WITH AUTO NEUTRAL, P. 17.....	198
11.19. EATON ULTRASHIFT GEN 3 / MERITOR — G — MANUAL TRANSMISSION, P. 18.....	199
11.20. EATON HYBRID TRANSMISSION, P. 19.....	200
11.21. EATON HYBRID TRANSMISSION, P. 20.....	201
11.22. EATON HYBRID TRANSMISSION, P. 21.....	202
11.23. EATON HYBRID TRANSMISSION, P. 22.....	203
11.24. EATON HYBRID TRANSMISSION, P. 23.....	204
11.25. TRANSMISSION ALLISON MD (WTEC) WITH CAT ENGINE, P. 24.....	205
11.26. FREEDOMLINE TRANSMISSION WITH CAT AND ISM ENGINE, P. 25.....	206
12. AIR CONDITIONING (CHAPTER 12).....	207
12.1. AIR CONDITIONING, P. 1.....	207
12.2. AIR CONDITIONING, P. 2.....	208
12.3. HVAC SYSTEM, P. 3.....	209
12.4. HVAC SYSTEM, P. 4.....	210
12.5. HVAC SYSTEM, P. 5.....	211
12.6. AUTOTHERM SYSTEM, P. 6.....	212
13. CONNECTOR COMPOSITES (CHAPTER 13).....	213
13.1. CONNECTOR COMPOSITES (1J), (2J), (71), P. 1.....	213
13.2. CONNECTOR COMPOSITES (72), (254F), (254M), (345), (400), P. 2.....	214
13.3. CONNECTOR COMPOSITES (421), (422), (422F), (423), (424), (425), P. 3.....	215
13.4. CONNECTOR COMPOSITES (520), (521), (522), (523), (524), (827), P. 4.....	216
13.5. CONNECTOR COMPOSITES (830), (1002), (1003), (1006), P. 5.....	217
13.6. CONNECTOR COMPOSITES (1008), (1009), P. 6.....	218
13.7. CONNECTOR COMPOSITE (1010), P. 7.....	219
13.8. CONNECTOR COMPOSITE (1011), P. 8.....	220
13.9. CONNECTOR COMPOSITE (1012), P. 9.....	221
13.10. CONNECTOR COMPOSITE (1013), P. 10.....	222
13.11. CONNECTOR COMPOSITE (1014), P. 11.....	223

13.12. CONNECTOR COMPOSITE (1015), P. 12.....	224
13.13. CONNECTOR COMPOSITE (1016), P. 13.....	225
13.14. CONNECTOR COMPOSITE (1017), P. 14.....	226
13.15. CONNECTOR COMPOSITE (1018), P. 15.....	227
13.16. CONNECTOR COMPOSITE (1019), P. 16.....	228
13.17. CONNECTOR COMPOSITES (1020), P. 17.....	229
13.18. CONNECTOR COMPOSITES (1021), (1022), (1023A), (1023B), P. 18.....	230
13.19. CONNECTOR COMPOSITES (1023C), (1023D), (1024), (1025), P. 18A.....	231
13.20. CONNECTOR COMPOSITES (1025), (1026), (1029), P. 19.....	232
13.21. CONNECTOR COMPOSITES (1100), (1100MA), (1101), (1101A), P. 20.....	233
13.22. CONNECTOR COMPOSITES (1105), (1106), (1107), (1108), P. 21.....	234
13.23. CONNECTOR COMPOSITES (1109), (1110), (1200), P. 22.....	235
13.24. CONNECTOR COMPOSITES (1210), (1227), (1227M), (1228), P. 23.....	236
13.25. CONNECTOR COMPOSITES (1229), (1230F), (1231), (1240F), P. 24.....	237
13.26. CONNECTOR COMPOSITES (1242), (1243), (1300), (1301), (1338), P. 25.....	238
13.27. CONNECTOR COMPOSITES (1378), (1400), (1401), (1402), P. 26.....	239
13.28. CONNECTOR COMPOSITES (1403), (1410), P. 26A.....	240
13.29. CONNECTOR COMPOSITES (1420), (1421), (1500), P. 27.....	241
13.30. CONNECTOR COMPOSITES (1501), (1510), (1511), (1512), P. 28.....	242
13.31. CONNECTOR COMPOSITES (1556), (1557), (1558), (1600), P. 29.....	243
13.32. CONNECTOR COMPOSITE (1601), P. 30.....	244
13.33. CONNECTOR COMPOSITE (1602), P. 31.....	245
13.34. CONNECTOR COMPOSITES (1603), (1604), (1620), (1623), P. 32.....	246
13.35. CONNECTOR COMPOSITES (1625), (1626), (1650), (1657), P. 33.....	247
13.36. CONNECTOR COMPOSITES (1660), (1661), P. 34.....	248
13.37. CONNECTOR COMPOSITE (1700), P. 35.....	249
13.38. CONNECTOR COMPOSITE (1700), P. 36.....	250
13.39. CONNECTOR COMPOSITE (1700), P. 37.....	251
13.40. CONNECTOR COMPOSITE (1701), P. 38.....	252
13.41. CONNECTOR COMPOSITE (1701), P. 39.....	253
13.42. CONNECTOR COMPOSITE (1701), P. 40.....	254
13.43. CONNECTOR COMPOSITE (1702), P. 41.....	255
13.44. CONNECTOR COMPOSITE (1702), P. 42.....	256
13.45. CONNECTOR COMPOSITE (1702), P. 43.....	257
13.46. CONNECTOR COMPOSITE (1702), P. 44.....	258
13.47. CONNECTOR COMPOSITES (1800), P. 45.....	259
13.48. CONNECTOR COMPOSITES (1804), (1807), (1808), P. 46.....	260
13.49. CONNECTOR COMPOSITES (1809), (1810), (1811), (1812), (1813), (1815), (1822), P. 47.....	261
13.50. CONNECTOR COMPOSITES (1820), (1821), P. 47A.....	262
13.51. CONNECTOR COMPOSITES (1823), (1824), (1825), (1826), (1827), P. 48.....	263
13.52. CONNECTOR COMPOSITES (1828), (1852), (1860), P. 48A.....	264
13.53. CONNECTOR COMPOSITES (1861), (1872), (1873), (1874), (1875), (1900), P. 49.....	265
13.54. CONNECTOR COMPOSITES (1901), (1902), (1910), (1912), (1916), P. 50.....	266
13.55. CONNECTOR COMPOSITES (1918), (1923), (1927), (1929), (1935), (2000), P. 51.....	267
13.56. CONNECTOR COMPOSITES (2000), (2002), (2003), (2004), (2005), (2006), P. 52.....	268
13.57. CONNECTOR COMPOSITES (2020), (2021), (2022), (2115), (2116), (2116M), (2117), (2117M), P. 53.....	269
13.58. CONNECTOR COMPOSITES (2301), (2302), (2303), (2304), (2305), (2502), P. 54.....	270
13.59. CONNECTOR COMPOSITES (2503), (2600), (2601), (2602), P. 55.....	271
13.60. CONNECTOR COMPOSITES (2700), (2700M), P. 56.....	272
13.61. CONNECTOR COMPOSITES (2701), (2701F), (2701G), (2702), P. 57.....	273
13.62. CONNECTOR COMPOSITES (2703), (3000), (3002), (3003), P. 58.....	274

13.63. CONNECTOR COMPOSITES (3100), (3200), (3201), P. 59.....	275
13.64. CONNECTOR COMPOSITES (3202), (3203), (3204), (3208), P. 60.....	276
13.65. CONNECTOR COMPOSITES (3209), (3210), (3211), (3400), (4003), (4004), P. 61.....	277
13.66. CONNECTOR COMPOSITES (4017), (4018), (4019), (4021), (4022), (4037), (4038), (4070), (4071), P. 62.....	278
13.67. CONNECTOR COMPOSITES (4087), (4087A), (4111M), (4120), (4320), P. 63.....	279
13.68. CONNECTOR COMPOSITES (4321), (4322), (4323), (4410D), (4410E), (4410F), P. 64.....	280
13.69. CONNECTOR COMPOSITES (4410H), (4410K), (4410L), (4410M), P. 65.....	281
13.70. CONNECTOR COMPOSITES (4450AM), (4450M), (4460AM), (4460BF), P. 66.....	282
13.71. CONNECTOR COMPOSITES (4460BM), (4460M), (4500), (4905), P. 67.....	283
13.72. CONNECTOR COMPOSITES (4906), (4950), (4951), (5117), P. 68.....	284
13.73. CONNECTOR COMPOSITES (6000), (6001), P. 69.....	285
13.74. CONNECTOR COMPOSITES (6010), (6011), P. 70.....	286
13.75. CONNECTOR COMPOSITES (6020M), P. 71.....	287
13.76. CONNECTOR COMPOSITES (6020), P. 72.....	288
13.77. CONNECTOR COMPOSITES (6022), (6023), P. 73.....	289
13.78. CONNECTOR COMPOSITES (6200), (6201), (6259), (6260), P. 74.....	290
13.79. CONNECTOR COMPOSITES (6261), (6262), (6263), (6304), (6323), P. 75.....	291
13.80. CONNECTOR COMPOSITES (6334), (6400), (6401), P. 76.....	292
13.81. CONNECTOR COMPOSITES (6402), (6403), (6406M), P. 77.....	293
13.82. CONNECTOR COMPOSITES (6407M), (6550), (6650), (6701), P. 77A.....	294
13.83. CONNECTOR COMPOSITES (6702), (6703), (6703M), (6704), P. 78.....	295
13.84. CONNECTOR COMPOSITES (6704M), (6712), (6714), (6747), P. 79.....	296
13.85. CONNECTOR COMPOSITES (6900), (6901), (7103), (7103M), (7104), P. 80.....	297
13.86. CONNECTOR COMPOSITES (7104), (7105), P. 81.....	298
13.87. CONNECTOR COMPOSITES (7110), (7111), P. 82.....	299
13.88. CONNECTOR COMPOSITES (7150), P. 83.....	300
13.89. CONNECTOR COMPOSITES (7150F), P. 84.....	301
13.90. CONNECTOR COMPOSITES (7151), P. 85.....	302
13.91. CONNECTOR COMPOSITES (7205M), (7206F), P. 86.....	303
13.92. CONNECTOR COMPOSITES (7210), (7211), (7212), (7213), P. 87.....	304
13.93. CONNECTOR COMPOSITES (7250), (7251), (7350), P. 88.....	305
13.94. CONNECTOR COMPOSITES (7500), (7502M), (7600), (7601), (7601M), P. 89.....	306
13.95. CONNECTOR COMPOSITES (7602), (7603), (7604), (7605), (7607), (7608), (7609), (7611), P. 90.....	307
13.96. CONNECTOR COMPOSITES (7615), (7700), (7702), (7703), (7801), P. 91.....	308
13.97. CONNECTOR COMPOSITES (7801M), (7802), P. 92.....	309
13.98. CONNECTOR COMPOSITES (7905), (7909), P. 93.....	310
13.99. CONNECTOR COMPOSITES (7910), (7911), P. 93A.....	311
13.100. CONNECTOR COMPOSITES (8000), (8001), (8102), (8103), (8150), (8151), P. 94.....	312
13.101. CONNECTOR COMPOSITES (8200), (8201), (8301), (8303), (8305), (8310), (8311), P. 95.....	313
13.102. CONNECTOR COMPOSITES (8312), (8500), (8501), (8502), (8502A), (8503), (8503A), P. 96.....	314
13.103. CONNECTOR COMPOSITES (8505), (8506), (8507), (8508), (8509), (8601), (8602), P. 97.....	315
13.104. CONNECTOR COMPOSITES (8700), (8701), (8750), P. 97A.....	316
13.105. CONNECTOR COMPOSITES (8800), (8801), (8802), (8803), P. 98.....	317
13.106. CONNECTOR COMPOSITES (8803), (8805), (8806), P. 99.....	318
13.107. CONNECTOR COMPOSITES (8807), (8809), (8900), (9001), P. 100.....	319
13.108. CONNECTOR COMPOSITES (9100), (9101), (9102), (9103), (9108), (9255), (9260), (9261), (9280), P. 101.....	320
13.109. CONNECTOR COMPOSITES (9300), (9303), P. 102.....	321

13.110. CONNECTOR COMPOSITES (9310), (9311), (9315), (9316), (9501), (9502), (9503), (9504), P. 103.....	322
13.111. CONNECTOR COMPOSITES (9506), (9510), (9510A), (9510B), (9510F), (9510M), P. 104.....	323
13.112. CONNECTOR COMPOSITE (9511), P. 105.....	324
13.113. CONNECTOR COMPOSITES (9512), (9513), (9514), P. 106.....	325
13.114. CONNECTOR COMPOSITES (9516), (9517), (9518), (9519), (9520), (9521), (9522), (9523), (9524), P. 107.....	326
13.115. CONNECTOR COMPOSITES (9524), (9530), P. 108.....	327
13.116. CONNECTOR COMPOSITES (9715), (9716), P. 109.....	328
13.117. CONNECTOR COMPOSITES (9718), (9719M), (9720), (9736), (9737), P. 110.....	329
13.118. CONNECTOR COMPOSITE (9740), P. 111.....	330
13.119. CONNECTOR COMPOSITES (9740), (9745), (9746), (9747), (9748), P. 112.....	331
13.120. CONNECTOR COMPOSITES (9751), (9752), (9753), (9753A), (9754), P. 113.....	332
13.121. CONNECTOR COMPOSITES (9758), (9759), (9760), P. 114.....	333
13.122. CONNECTOR COMPOSITE (9761), P. 115.....	334
13.123. CONNECTOR COMPOSITES (9761F), (9762), (9763), (9764), (9765), (9766), P. 116.....	335
13.124. CONNECTOR COMPOSITES (9775), (9777), (9777A), (9778), P. 117.....	336
13.125. CONNECTOR COMPOSITES (9779F), (9780M), (9781M), (9782F), P. 118.....	337
13.126. CONNECTOR COMPOSITES (9800), P. 119.....	338
13.127. CONNECTOR COMPOSITES (9811), (9812), (9814), (9815), (9820M), P. 120.....	339
13.128. CONNECTOR COMPOSITES (9830), (9832), (9900), (9900E), P. 121.....	340
13.129. CONNECTOR COMPOSITES (9913B), (9915), (9920), (9921), (9994), (9999), P. 122.....	341

1. TABLE OF CONTENTS (CHAPTER 1)

2. INSTRUCTIONS AND CHARTS (CHAPTER 2)

2.1. ABBREVIATIONS, P. 1

INTERNATIONAL TRUCK AND ENGINE CORPORATION				ELECTRICAL CIRCUIT DIAGRAM CHAPTER 2	
THIS PRINT IS PROVIDED ON A RESTRICTED BASIS AND IS NOT TO BE USED IN ANY WAY DETRIMENTAL TO THE INTEREST OF INTERNATIONAL TRUCK AND ENGINE CORPORATION.				ABBREVIATIONS	
ABBREVIATION	DESCRIPTION	ABBREVIATION	DESCRIPTION	ABBREVIATION	DESCRIPTION
ACCESS	ACCESSORY	CRUS	CRUISE	PWR	POWER
ACCUM	ACCUMULATOR	CUR	CURRENT	PRESS	PRESSURE
AC	AIR CONDITIONING	DPNL	DASHBOARD	RAD	RADIO
AIR CLNR	AIR CLEANER	DFTR	DEFLECTOR	RLY	RELAY
ALT	ALTERNATOR	DFR	DEFROSTER	RES	RESISTOR
ACCEL	ACCELERATOR	DEG	DEGREE	REGEN	REGENERATE
AFTR	AFTERTREATMENT	DIAG	DIAGRAM	R	RIGHT
AMM	AMMETER	DSL	DIESEL	RTR	ROTOR
AMP	AMPERE	DIFF	DIFFERENTIAL	SNSR	SENSOR
AMP HR	AMPERE HOUR	DIMR	DIMMER	SHLD	SHIELD
AMPL	AMPLIFIER	ELEC	ELECTRICAL	SHFT	SHIFTER
ARM	ARMATURE	ELEX	ELECTRONIC	SLPR	SLEEPER
ARSR	ARRESTER	ENG	ENGINE	SLV	SLEEVE
ASSY	ASSEMBLY	EXH	EXHAUST	SPKR	SPEAKER
AUX	AUXILIARY	FL	FLUID	SPR	SPRING
B/U	BACK-UP	FWD	FORWARD	STD	STANDARD
BTRY	BATTERY	FR	FRONT	STRG	STEERING
BM	BENCHMARKING	FREQ	FREQUENCY	STLITE	SATELLITE
BLK	BLOCK	GA	GAUGE	SUNSH	SUNSHADE
BOOS	BOOSTER	GEN	GENERATOR	SW	SWITCH
BOT	BOTTOM	GND	GROUND	SYS	SYSTEM
BK	BRAKE	HARN	HARNESS	TACH	TACHOMETER
BRKR	BREAKER	HDLP	HEADLAMP	TEMP	TEMPERATURE
BRTHR	BREATHER	HTD	HEATED	TERM	TERMINAL
BRI	BRIGHT	HT TR	HEAT TREAT	THROT	THROTTLE
BUZ	BUZZER	HTR	HEATER	THRU	THROUGH
CA	CABLE	HP	HORSEPOWER	TRAC	TRACTION
CD	CANDELA	HYD	HYDRAULIC	TRLR	TRAILER
CP	CANDLEPOWER	ID	IDENTIFICATION	XDCR	TRANSDUCER
CAP	CAPACITOR	IGN	IGNITION	XFER	TRANSFER
CAT	CATERPILLAR	ILLUM	ILLUMINATION	XFMR	TRANSFORMER
CHAS	CHASSIS	IND	INDICATOR	XSTR	TRANSISTOR
CH	CHOKE	INST	INSTRUMENT	XMSN	TRANSMISSION
CIRC	CIRCUIT	INT	INTERMITTENT	XMTR	TRANSMITTER
CLK	CLOCK	L	LEFT	TRK	TRUCK
CW	CLOCKWISE	LT	LIGHT	UPR	UPPER
CLSTR	CLUSTER	LTR	LIGHTER	VLV	VALVE
CL	CLUTCH	LWR	LOWER	VERT	VERTICAL
COL	COLUMN	MAG	MAGNET	VM	VOLTMETER
COMM	COMMUTATOR	MOD	MODULATOR	VOL	VOLUME
COMPNT	COMPONENT	MDL	MODULE	WSHR	WASHER
CPRSR	COMPRESSOR	MOT	MOTOR	WHL	WHEEL
CONN	CONNECTOR	MTD	MOUNTED	WDO	WINDOW
CONT	CONTINUE	NEG	NEGATIVE	WSHLD	WINDSHIELD
CSL	CONSOLE	N/	NOT WITH	WPR	WIPER
CONT	CONTACT	NO	NUMBER	W/	WITH
CONT	CONTROL	PASS	PASSENGER	W/O	WITHOUT
CONV	CONVERTER	POSN	POSITION		
CLR	COOLER	POS	POSITIVE		
CTSY	COURTESY	POT	POTENTIOMETER		

CHK	DATE	CHANGE	REV	REFERENCE	DRAWN	NAME
RAW6	04DEC07	DELETED AC & RR FROM	B	61000T	U00K640	CIRCUIT DIAGRAM, 42/43/44/85/8600 & 73/74/7500
	ABBREVIATIONS LIST				RELEASE NO.	DATE
					59974G	12SEP06
					PART NO.	SHEET
					AE08056608	001

Figure 1 Abbreviations

2.2. ACRONYMS, P. 2

INTERNATIONAL TRUCK AND ENGINE CORPORATION		ELECTRICAL CIRCUIT DIAGRAM CHAPTER 2																																																																																																																																																																																					
THIS PRINT IS PROVIDED ON A RESTRICTED BASIS AND IS NOT TO BE USED IN ANY WAY DETRIMENTAL TO THE INTEREST OF INTERNATIONAL TRUCK AND ENGINE CORPORATION.		ACRONYMS																																																																																																																																																																																					
<table border="1" style="width: 100%; border-collapse: collapse;"> <thead> <tr> <th style="width: 50%;">DESCRIPTION</th> <th style="width: 50%;">ACRONYM</th> <th style="width: 50%;">DESCRIPTION</th> <th style="width: 50%;">ACRONYM</th> </tr> </thead> <tbody> <tr><td>ANTILOCK BRAKING SYSTEM</td><td>ABS</td><td>HEAVY DUTY DIESEL</td><td>HDD</td></tr> <tr><td>ANTENNA COMMUNICATION UNIT</td><td>ACU</td><td>HIGH PERFORMANCE TRUCK</td><td>HPT</td></tr> <tr><td>ALTERNATING CURRENT</td><td>AC</td><td>HIGH SIDE DRIVER</td><td>HSD</td></tr> <tr><td>AXLE TO BACK OF CAB</td><td>AC</td><td>HEATING, VENTILATION, AND AIR CONDITIONING</td><td>HVAC</td></tr> <tr><td>AXLE TO FRAME</td><td>AF</td><td>INJECTOR DRIVE MODULE</td><td>IDM</td></tr> <tr><td>ACCELERATOR PEDAL MODULE</td><td>APM</td><td>INPUT/OUTPUT</td><td>I/O</td></tr> <tr><td>ACCELERATOR POSITION SENSOR</td><td>APS</td><td>INTEGRATED MOBILE COMMUNICATION TERMINAL</td><td>IMCT</td></tr> <tr><td>AUXILIARY POWER UNIT</td><td>APU</td><td>INSTRUMENT PANEL</td><td>I/P</td></tr> <tr><td>AMERICAN TRUCKING ASSOCIATION</td><td>ATA</td><td>INDEPENDENT POWER TAKE-OFF</td><td>IPTO</td></tr> <tr><td>AUTOMATIC TRACTION CONTROL</td><td>ATC</td><td>INPUT SPEED SENSOR</td><td>ISS</td></tr> <tr><td>AUDIO VIDEO INTERFACE</td><td>AVI</td><td>LIGHT COMMERCIAL TRANSMISSION</td><td>LCT</td></tr> <tr><td>BAROMETRIC ATMOSPHERE PRESSURE</td><td>BAP</td><td>LOW PRESSURE MODULE</td><td>LPM</td></tr> <tr><td>BRAKE HORSEPOWER</td><td>BHP</td><td>LOW SIDE DRIVE</td><td>LSD</td></tr> <tr><td>BACK OF CAB</td><td>BOC</td><td>MEDIUM DUTY</td><td>MD</td></tr> <tr><td>CITIZEN BAND</td><td>CB</td><td>MOMENTARY ENGINE IGNITION INTERRUPT RELAY</td><td>MEIIR</td></tr> <tr><td>COLD CRANKING AMPERES</td><td>CCA</td><td>MAJFUNCTION INDICATION LAMP</td><td>MIL</td></tr> <tr><td>CLEAN POWER ELECTRICAL CONNECTOR</td><td>CEC</td><td>MULTIPLY SWITCH MODULE</td><td>MSM</td></tr> <tr><td>CENTRAL JUNCTION BOX</td><td>CJB</td><td>OUTPUT SPEED SENSOR</td><td>OSS</td></tr> <tr><td>CENTRAL PROCESSING UNIT</td><td>CPU</td><td>PYROMETER AMMETER MODULE</td><td>PAM</td></tr> <tr><td>CAB OVER ENGINE</td><td>COE</td><td>POWER DISTRIBUTION CENTER</td><td>PDC</td></tr> <tr><td>DIRECT CURRENT</td><td>DC</td><td>PROGRAMMABLE LOGIC CONTROLLER</td><td>PLC</td></tr> <tr><td>DRIVER CONTROL MODULE</td><td>DCM</td><td>POWER TAKE-OFF</td><td>PTO</td></tr> <tr><td>DIGITAL DATA LINK</td><td>DDL</td><td>PULSE WIDTH MODULATION</td><td>PWM</td></tr> <tr><td>DIESEL OXIDATION CATALYST INLET TEMPERATURE</td><td>DOCT</td><td>REAR AXLE</td><td>RA</td></tr> <tr><td>DIESEL PARTICULATE FILTER</td><td>DPF</td><td>RADIO FREQUENCY</td><td>RF</td></tr> <tr><td>DIESEL PARTICULATE FILTER DELTA PRESSURE</td><td>DPFDP</td><td>ROLL STABILITY PROGRAM</td><td>RSP</td></tr> <tr><td>DIESEL PARTICULATE FILTER TEMPERATURE</td><td>DPFT</td><td>SEVERE SERVICE</td><td>SS</td></tr> <tr><td>DIESEL TURBOCHARGED</td><td>DT</td><td>TRANSMISSION CONTROL MODULE</td><td>TCM</td></tr> <tr><td>DAY TIME RUNNING LIGHTS</td><td>DTRL</td><td>TERRESTRIAL COMMUNICATION UNIT</td><td>TCU</td></tr> <tr><td>ELECTRONIC CONTROL MODULE</td><td>ECM</td><td>TERRESTRIAL MOBILE COMMUNICATION TERMINAL</td><td>TMCT</td></tr> <tr><td>ELECTRONIC CONTROL UNIT</td><td>ECU</td><td>THERMAL OVERCRANK PROTECTION</td><td>TOCP</td></tr> <tr><td>EXHAUST GAS RECIRCULATION</td><td>EGR</td><td>THROTTLE POSITION SENSOR</td><td>TPS</td></tr> <tr><td>EXHAUST GAS TEMPERATURE</td><td>EGT</td><td>TURBINE SPEED SENSOR</td><td>TSS</td></tr> <tr><td>ELECTRO MAGNETIC INTERFERENCE</td><td>EMI</td><td>VEHICLE SPEED OUTPUT</td><td>VSO</td></tr> <tr><td>END OF FRAME</td><td>EOF</td><td>VEHICLE SPEED SENSOR</td><td>VSS</td></tr> <tr><td>ELECTRIC TRAILER BRAKE</td><td>ETB</td><td>WORLD TRANSMISSION ELECTRONIC CONTROLS</td><td>WTEC</td></tr> <tr><td>FRONT AXLE</td><td>FA</td><td>ZERO VOLT REFERENCE</td><td>ZVR</td></tr> <tr><td>FRONT END</td><td>FE</td><td></td><td></td></tr> <tr><td>FRONT OF DASH</td><td>FOD</td><td></td><td></td></tr> <tr><td>FULL POWER BRAKE</td><td>FPB</td><td></td><td></td></tr> <tr><td>GENERIC ELECTRONIC MODULE</td><td>GEM</td><td></td><td></td></tr> <tr><td>GLOBAL POSITIONING SYSTEM</td><td>GPS</td><td></td><td></td></tr> <tr><td>HYDRAULIC CONTROL UNIT</td><td>HCU</td><td></td><td></td></tr> <tr><td>HEAVY DUTY</td><td>HD</td><td></td><td></td></tr> </tbody> </table>				DESCRIPTION	ACRONYM	DESCRIPTION	ACRONYM	ANTILOCK BRAKING SYSTEM	ABS	HEAVY DUTY DIESEL	HDD	ANTENNA COMMUNICATION UNIT	ACU	HIGH PERFORMANCE TRUCK	HPT	ALTERNATING CURRENT	AC	HIGH SIDE DRIVER	HSD	AXLE TO BACK OF CAB	AC	HEATING, VENTILATION, AND AIR CONDITIONING	HVAC	AXLE TO FRAME	AF	INJECTOR DRIVE MODULE	IDM	ACCELERATOR PEDAL MODULE	APM	INPUT/OUTPUT	I/O	ACCELERATOR POSITION SENSOR	APS	INTEGRATED MOBILE COMMUNICATION TERMINAL	IMCT	AUXILIARY POWER UNIT	APU	INSTRUMENT PANEL	I/P	AMERICAN TRUCKING ASSOCIATION	ATA	INDEPENDENT POWER TAKE-OFF	IPTO	AUTOMATIC TRACTION CONTROL	ATC	INPUT SPEED SENSOR	ISS	AUDIO VIDEO INTERFACE	AVI	LIGHT COMMERCIAL TRANSMISSION	LCT	BAROMETRIC ATMOSPHERE PRESSURE	BAP	LOW PRESSURE MODULE	LPM	BRAKE HORSEPOWER	BHP	LOW SIDE DRIVE	LSD	BACK OF CAB	BOC	MEDIUM DUTY	MD	CITIZEN BAND	CB	MOMENTARY ENGINE IGNITION INTERRUPT RELAY	MEIIR	COLD CRANKING AMPERES	CCA	MAJFUNCTION INDICATION LAMP	MIL	CLEAN POWER ELECTRICAL CONNECTOR	CEC	MULTIPLY SWITCH MODULE	MSM	CENTRAL JUNCTION BOX	CJB	OUTPUT SPEED SENSOR	OSS	CENTRAL PROCESSING UNIT	CPU	PYROMETER AMMETER MODULE	PAM	CAB OVER ENGINE	COE	POWER DISTRIBUTION CENTER	PDC	DIRECT CURRENT	DC	PROGRAMMABLE LOGIC CONTROLLER	PLC	DRIVER CONTROL MODULE	DCM	POWER TAKE-OFF	PTO	DIGITAL DATA LINK	DDL	PULSE WIDTH MODULATION	PWM	DIESEL OXIDATION CATALYST INLET TEMPERATURE	DOCT	REAR AXLE	RA	DIESEL PARTICULATE FILTER	DPF	RADIO FREQUENCY	RF	DIESEL PARTICULATE FILTER DELTA PRESSURE	DPFDP	ROLL STABILITY PROGRAM	RSP	DIESEL PARTICULATE FILTER TEMPERATURE	DPFT	SEVERE SERVICE	SS	DIESEL TURBOCHARGED	DT	TRANSMISSION CONTROL MODULE	TCM	DAY TIME RUNNING LIGHTS	DTRL	TERRESTRIAL COMMUNICATION UNIT	TCU	ELECTRONIC CONTROL MODULE	ECM	TERRESTRIAL MOBILE COMMUNICATION TERMINAL	TMCT	ELECTRONIC CONTROL UNIT	ECU	THERMAL OVERCRANK PROTECTION	TOCP	EXHAUST GAS RECIRCULATION	EGR	THROTTLE POSITION SENSOR	TPS	EXHAUST GAS TEMPERATURE	EGT	TURBINE SPEED SENSOR	TSS	ELECTRO MAGNETIC INTERFERENCE	EMI	VEHICLE SPEED OUTPUT	VSO	END OF FRAME	EOF	VEHICLE SPEED SENSOR	VSS	ELECTRIC TRAILER BRAKE	ETB	WORLD TRANSMISSION ELECTRONIC CONTROLS	WTEC	FRONT AXLE	FA	ZERO VOLT REFERENCE	ZVR	FRONT END	FE			FRONT OF DASH	FOD			FULL POWER BRAKE	FPB			GENERIC ELECTRONIC MODULE	GEM			GLOBAL POSITIONING SYSTEM	GPS			HYDRAULIC CONTROL UNIT	HCU			HEAVY DUTY	HD		
DESCRIPTION	ACRONYM	DESCRIPTION	ACRONYM																																																																																																																																																																																				
ANTILOCK BRAKING SYSTEM	ABS	HEAVY DUTY DIESEL	HDD																																																																																																																																																																																				
ANTENNA COMMUNICATION UNIT	ACU	HIGH PERFORMANCE TRUCK	HPT																																																																																																																																																																																				
ALTERNATING CURRENT	AC	HIGH SIDE DRIVER	HSD																																																																																																																																																																																				
AXLE TO BACK OF CAB	AC	HEATING, VENTILATION, AND AIR CONDITIONING	HVAC																																																																																																																																																																																				
AXLE TO FRAME	AF	INJECTOR DRIVE MODULE	IDM																																																																																																																																																																																				
ACCELERATOR PEDAL MODULE	APM	INPUT/OUTPUT	I/O																																																																																																																																																																																				
ACCELERATOR POSITION SENSOR	APS	INTEGRATED MOBILE COMMUNICATION TERMINAL	IMCT																																																																																																																																																																																				
AUXILIARY POWER UNIT	APU	INSTRUMENT PANEL	I/P																																																																																																																																																																																				
AMERICAN TRUCKING ASSOCIATION	ATA	INDEPENDENT POWER TAKE-OFF	IPTO																																																																																																																																																																																				
AUTOMATIC TRACTION CONTROL	ATC	INPUT SPEED SENSOR	ISS																																																																																																																																																																																				
AUDIO VIDEO INTERFACE	AVI	LIGHT COMMERCIAL TRANSMISSION	LCT																																																																																																																																																																																				
BAROMETRIC ATMOSPHERE PRESSURE	BAP	LOW PRESSURE MODULE	LPM																																																																																																																																																																																				
BRAKE HORSEPOWER	BHP	LOW SIDE DRIVE	LSD																																																																																																																																																																																				
BACK OF CAB	BOC	MEDIUM DUTY	MD																																																																																																																																																																																				
CITIZEN BAND	CB	MOMENTARY ENGINE IGNITION INTERRUPT RELAY	MEIIR																																																																																																																																																																																				
COLD CRANKING AMPERES	CCA	MAJFUNCTION INDICATION LAMP	MIL																																																																																																																																																																																				
CLEAN POWER ELECTRICAL CONNECTOR	CEC	MULTIPLY SWITCH MODULE	MSM																																																																																																																																																																																				
CENTRAL JUNCTION BOX	CJB	OUTPUT SPEED SENSOR	OSS																																																																																																																																																																																				
CENTRAL PROCESSING UNIT	CPU	PYROMETER AMMETER MODULE	PAM																																																																																																																																																																																				
CAB OVER ENGINE	COE	POWER DISTRIBUTION CENTER	PDC																																																																																																																																																																																				
DIRECT CURRENT	DC	PROGRAMMABLE LOGIC CONTROLLER	PLC																																																																																																																																																																																				
DRIVER CONTROL MODULE	DCM	POWER TAKE-OFF	PTO																																																																																																																																																																																				
DIGITAL DATA LINK	DDL	PULSE WIDTH MODULATION	PWM																																																																																																																																																																																				
DIESEL OXIDATION CATALYST INLET TEMPERATURE	DOCT	REAR AXLE	RA																																																																																																																																																																																				
DIESEL PARTICULATE FILTER	DPF	RADIO FREQUENCY	RF																																																																																																																																																																																				
DIESEL PARTICULATE FILTER DELTA PRESSURE	DPFDP	ROLL STABILITY PROGRAM	RSP																																																																																																																																																																																				
DIESEL PARTICULATE FILTER TEMPERATURE	DPFT	SEVERE SERVICE	SS																																																																																																																																																																																				
DIESEL TURBOCHARGED	DT	TRANSMISSION CONTROL MODULE	TCM																																																																																																																																																																																				
DAY TIME RUNNING LIGHTS	DTRL	TERRESTRIAL COMMUNICATION UNIT	TCU																																																																																																																																																																																				
ELECTRONIC CONTROL MODULE	ECM	TERRESTRIAL MOBILE COMMUNICATION TERMINAL	TMCT																																																																																																																																																																																				
ELECTRONIC CONTROL UNIT	ECU	THERMAL OVERCRANK PROTECTION	TOCP																																																																																																																																																																																				
EXHAUST GAS RECIRCULATION	EGR	THROTTLE POSITION SENSOR	TPS																																																																																																																																																																																				
EXHAUST GAS TEMPERATURE	EGT	TURBINE SPEED SENSOR	TSS																																																																																																																																																																																				
ELECTRO MAGNETIC INTERFERENCE	EMI	VEHICLE SPEED OUTPUT	VSO																																																																																																																																																																																				
END OF FRAME	EOF	VEHICLE SPEED SENSOR	VSS																																																																																																																																																																																				
ELECTRIC TRAILER BRAKE	ETB	WORLD TRANSMISSION ELECTRONIC CONTROLS	WTEC																																																																																																																																																																																				
FRONT AXLE	FA	ZERO VOLT REFERENCE	ZVR																																																																																																																																																																																				
FRONT END	FE																																																																																																																																																																																						
FRONT OF DASH	FOD																																																																																																																																																																																						
FULL POWER BRAKE	FPB																																																																																																																																																																																						
GENERIC ELECTRONIC MODULE	GEM																																																																																																																																																																																						
GLOBAL POSITIONING SYSTEM	GPS																																																																																																																																																																																						
HYDRAULIC CONTROL UNIT	HCU																																																																																																																																																																																						
HEAVY DUTY	HD																																																																																																																																																																																						
CHK	DATE	CHANGE	REV	REFERENCE	DRAWN	NAME																																																																																																																																																																																	
RAW6	04DEC07	REVISED AND REDRAWN	B	61000T	U00K640	CIRCUIT DIAGRAM, 42/43/44/85/8600 & 73/74/7500																																																																																																																																																																																	
					RELEASE NO.	DATE	PART NO.																																																																																																																																																																																
					59974G	12SEP06	AE08056608																																																																																																																																																																																
							SHEET 002																																																																																																																																																																																

Figure 2 Acronyms

2.3. CIRCUIT DIAGRAM INSTRUCTIONS, P. 3







<p>INTERNATIONAL TRUCK AND ENGINE CORPORATION THIS PRINT IS PROVIDED ON A RESTRICTED BASIS AND IS NOT TO BE USED IN ANY WAY DETRIMENTAL TO THE INTEREST OF INTERNATIONAL TRUCK AND ENGINE CORPORATION.</p>	<p>ELECTRICAL CIRCUIT DIAGRAM CHAPTER 2 CIRCUIT DIAGRAM INSTRUCTIONS</p>																																										
<p>A - SWITCH AND RELAY POSITIONS AS SHOWN ON CIRCUIT DIAGRAMS INDICATE NORMAL POSITION WITH IGNITION OFF UNLESS OTHERWISE NOTED.</p> <div style="display: flex; justify-content: space-around;"> <div style="text-align: center;">  <p>SWITCH, MECHANICAL</p> </div> <div style="text-align: center;">  <p>SOLENOID</p> </div> <div style="text-align: center;">  <p>RELAY - SUPPRESSED</p> </div> </div>	<p>B - MULTIPLE CONNECTIONS ARE DISPLAYED ON SCHEMATIC AS SHOWN WITH R/D NUMBER & CAVITY NUMBER. REFER TO CONNECTOR COMPOSITE FOR MORE INFORMATION</p> <div style="display: flex; justify-content: space-around;"> <div style="text-align: center;">  <p>R/D NUMBER CAVITY NUMBER</p> </div> <div style="text-align: center;">  <p>CAVITY NUMBER R/D NUMBER</p> </div> </div> <p>AND/OR</p> <div style="text-align: center;">  <p>SINGLE IN-LINE CONNECTORS DISPLAYED AS SHOWN BELOW WITHOUT R/D NUMBER</p> </div>																																										
<p>C - PHANTOM LINES INDICATE PRINTED CIRCUITS OR BUSSED CIRCUITS. THESE CIRCUITS EXIST IN THE INSTRUMENT CLUSTER AND FUSE / CIRCUIT BREAKER CONNECTORS.</p> <div style="display: flex; justify-content: space-around;"> <div style="text-align: center;">  <p>PRINTED CIRCUIT IN INSTRUMENT CLUSTER</p> </div> <div style="text-align: center;">  <p>VOLTMETER</p> </div> <div style="text-align: center;">  <p>LOCATION / CIRCUIT NUMBER WIRE GAUGE / WIRE COLOR</p> <p>LOCATION IN FUSE / CIRCUIT BREAKER CONNECTION</p> <p>FUSE RATING</p> </div> </div>																																											
<p>D - MULTIPLE CIRCUIT NUMBERS ON A LINE INDICATE ONE CIRCUIT DISTRIBUTING CURRENT TO TWO CIRCUITS.</p> <div style="text-align: center;">  <p>SPLICE</p> </div>																																											
<p>E - SWITCHES, RELAYS AND COMPONENTS INDICATE EXTERNAL WIRE CONNECTIONS AND / OR INTERNAL CONNECTIONS OR CONTACTS.</p> <div style="display: flex; justify-content: space-around;"> <div style="text-align: center;">  <p>KEY SWITCH (1101M)</p> </div> <div style="text-align: center;">  <p>EXTERNAL WIRE CONNECTIONS</p> <p>WIRE CONNECTION</p> <p>BUSSED CONTACT</p> </div> <div style="text-align: center;">  <p>PIGTAIL</p> <p>16RD</p> <p>16WH</p> <p>BODY CONTROLLER (1602)</p> </div> </div>																																											
<p>F - CIRCUIT "11" DENOTES ANY COMMON GROUND (MORE THAN ONE CIRCUIT). ANY INDIVIDUAL GROUND CIRCUIT IS IDENTIFIED WITH THAT PARTICULAR CIRCUIT NUMBER. I.E.G. CIRCUIT 32 CRUISE CONTROL IS IDENTIFIED AS PER EXAMPLE)</p> <div style="display: flex; justify-content: space-around;"> <div style="text-align: center;">  <p>COMMON GROUND CIRCUIT NUMBER</p> </div> <div style="text-align: center;">  <p>SUFFIX BEGINNING WITH G INDICATES A GROUND CIRCUIT</p> </div> <div style="text-align: center;">  <p>INDIVIDUAL GROUND CIRCUIT NUMBER</p> </div> <div style="text-align: center;">  <p>SUFFIX BEGINNING WITH G INDICATES A GROUND CIRCUIT</p> </div> </div> <p style="text-align: center; margin-top: 10px;">NOTE: FOR CIRCUIT DESCRIPTION OTHER THAN GROUNDS NEITHER THE LETTER "G" NOR THE COLOR WHITE SHALL BE USED</p>																																											
<table border="1" style="width: 100%; border-collapse: collapse; font-size: small;"> <tr> <td>CHK</td> <td>DATE</td> <td>CHANGE</td> <td>REV</td> <td>REFERENCE</td> <td>DRAWN</td> <td>NAME</td> </tr> <tr> <td>CNA</td> <td>05MAY07</td> <td>REVISED & REDRAWN</td> <td>A</td> <td>60782A</td> <td>U00K640</td> <td>42/43/44/85/8600 & 73/74/7500 CIRC DIAGRAMS</td> </tr> <tr> <td></td> <td></td> <td></td> <td></td> <td></td> <td>RELEASE NO.</td> <td>DATE</td> </tr> <tr> <td></td> <td></td> <td></td> <td></td> <td></td> <td>59974G</td> <td>20APR06</td> </tr> <tr> <td></td> <td></td> <td></td> <td></td> <td></td> <td>PART NO.</td> <td>SHEET</td> </tr> <tr> <td></td> <td></td> <td></td> <td></td> <td></td> <td>AE08-56608</td> <td>03</td> </tr> </table>		CHK	DATE	CHANGE	REV	REFERENCE	DRAWN	NAME	CNA	05MAY07	REVISED & REDRAWN	A	60782A	U00K640	42/43/44/85/8600 & 73/74/7500 CIRC DIAGRAMS						RELEASE NO.	DATE						59974G	20APR06						PART NO.	SHEET						AE08-56608	03
CHK	DATE	CHANGE	REV	REFERENCE	DRAWN	NAME																																					
CNA	05MAY07	REVISED & REDRAWN	A	60782A	U00K640	42/43/44/85/8600 & 73/74/7500 CIRC DIAGRAMS																																					
					RELEASE NO.	DATE																																					
					59974G	20APR06																																					
					PART NO.	SHEET																																					
					AE08-56608	03																																					

Figure 3 Circuit Diagram Instructions

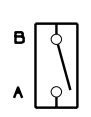
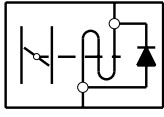
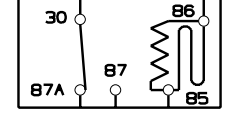
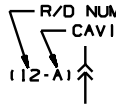
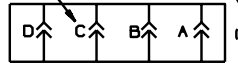
2.4. CIRCUIT NUMBER IDENTIFICATION AND COLOR, P. 4

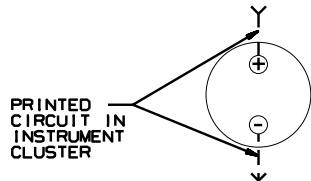
INTERNATIONAL TRUCK AND ENGINE CORPORATION <small>THIS PRINT IS PROVIDED ON A RESTRICTED BASIS AND IS NOT TO BE USED IN ANY WAY DETRIMENTAL TO THE INTEREST OF INTERNATIONAL TRUCK AND ENGINE CORPORATION.</small>		ELECTRICAL CIRCUIT DIAGRAM CHAPTER 2 CIRCUIT NUMBER IDENTIFICATION AND COLOR																																																																																																																																																			
<table border="1" style="width:100%; border-collapse: collapse;"> <thead> <tr> <th style="width:10%;">CIRCUIT NUMBER</th> <th style="width:10%;">COLOR</th> <th style="width:80%;">DESCRIPTION</th> </tr> </thead> <tbody> <tr><td>1</td><td>LTBL</td><td>ALTERNATOR - FIELD</td></tr> <tr><td>2</td><td>RD</td><td>ALTERNATOR - CHARGE</td></tr> <tr><td rowspan="2">3</td><td>DKBL</td><td>SERIAL / DATA COMMUNICATION J1587 / J1708 (+)</td></tr> <tr><td>GY</td><td>SERIAL / DATA COMMUNICATION J1587 / J1708 (-)</td></tr> <tr><td rowspan="2">4</td><td>DKBL</td><td>SERIAL / DATA COMMUNICATION J1922 (+)</td></tr> <tr><td>GY</td><td>SERIAL / DATA COMMUNICATION J1922 (-)</td></tr> <tr><td rowspan="2">5</td><td>YL</td><td>SERIAL / DATA COMMUNICATION J1939 /11 / J1939/15 (+)</td></tr> <tr><td>GN</td><td>SERIAL / DATA COMMUNICATION J1939 /11 / J1939/15 (-)</td></tr> <tr><td>6</td><td>GY</td><td>LOW VOLTAGE ELECTRONIC FEED (LESS THAN 9 VOLTS)</td></tr> <tr><td>7</td><td>RD</td><td>ALTERNATOR - RESISTANCE</td></tr> <tr><td>8</td><td></td><td></td></tr> <tr><td>9</td><td>GY</td><td>LOW VOLTAGE ELECTRONIC GROUND</td></tr> <tr><td>10</td><td>WH</td><td>CHASSIS / ENGINE GROUND</td></tr> <tr><td>11</td><td>WH</td><td>CAB / SLEEPER GROUND</td></tr> <tr><td>12</td><td>LTBL</td><td>ACCESSORY FEED</td></tr> <tr><td rowspan="2">13</td><td>PK</td><td>IGNITION FEED</td></tr> <tr><td>BK</td><td>IGNITION FEED (BODY BUILDER CONNECTOR)</td></tr> <tr><td>14</td><td>RD</td><td>BATTERY FEED</td></tr> <tr><td>15</td><td>RD</td><td>KEY SWITCH FEED</td></tr> <tr><td>16</td><td></td><td></td></tr> <tr><td>17</td><td>PK</td><td>STARTER CONTROL</td></tr> <tr><td>18</td><td>PK</td><td>GLOW PLUG / PRE-HEATER</td></tr> <tr><td>19</td><td>GY</td><td>ENGINE SHUTDOWN</td></tr> <tr><td>20</td><td>LTGN</td><td>REMOTE POWER MODULE</td></tr> <tr><td>21</td><td>TN</td><td>COLD START CONTROLS (ETHER)</td></tr> <tr><td>22</td><td>TN</td><td>TIRE PRESSURE MONITORING / CONTROL</td></tr> <tr><td>23</td><td>TN</td><td>ENGINE FAN / SHUTTERS</td></tr> <tr><td>24</td><td>GY</td><td>ENGINE EXHAUST BRAKE</td></tr> <tr><td>25</td><td>TN</td><td>PYROMETER</td></tr> <tr><td>26</td><td>TN</td><td>AMMETER</td></tr> <tr><td>27</td><td>TN</td><td>VOLTMETER</td></tr> <tr><td>28</td><td>TN</td><td>INSTRUMENTS AND GAUGES</td></tr> <tr><td>29</td><td>TN</td><td>ENGINE WATER TEMPERATURE</td></tr> <tr><td>30</td><td>TN</td><td>ENGINE OIL TEMPERATURE</td></tr> <tr><td>31</td><td>TN</td><td>TRANSMISSION OIL TEMPERATURE</td></tr> <tr><td>32</td><td>TN</td><td>AXLE OIL TEMPERATURE</td></tr> <tr><td>33</td><td>TN</td><td>ENGINE OIL LEVEL</td></tr> <tr><td>34</td><td>TN</td><td>COOLANT LEVEL</td></tr> <tr><td>35</td><td>TN</td><td>ENGINE OIL PRESSURE</td></tr> <tr><td>36</td><td>TN</td><td>FUEL LEVEL</td></tr> <tr><td>37</td><td>TN</td><td>FUEL PUMP</td></tr> <tr><td>38</td><td>GY</td><td>LIFT AXLE</td></tr> <tr><td>39</td><td>GY</td><td>AIR DRYER HEATER</td></tr> <tr><td>40</td><td>GY</td><td>LOW AIR PRESSURE WARNING</td></tr> <tr><td>41</td><td>TN</td><td>AIR TEMPERATURE</td></tr> <tr><td>42</td><td>GY</td><td>FRONT AXLE ENGAGED</td></tr> <tr><td>43</td><td>GY</td><td>POWER DIVIDER LOCK (PDL) WARNING</td></tr> <tr><td>44</td><td>GY</td><td>PARK BRAKE WARNING</td></tr> <tr><td>45</td><td>LTGN</td><td>ANTI-THEFT WARNING</td></tr> </tbody> </table>				CIRCUIT NUMBER	COLOR	DESCRIPTION	1	LTBL	ALTERNATOR - FIELD	2	RD	ALTERNATOR - CHARGE	3	DKBL	SERIAL / DATA COMMUNICATION J1587 / J1708 (+)	GY	SERIAL / DATA COMMUNICATION J1587 / J1708 (-)	4	DKBL	SERIAL / DATA COMMUNICATION J1922 (+)	GY	SERIAL / DATA COMMUNICATION J1922 (-)	5	YL	SERIAL / DATA COMMUNICATION J1939 /11 / J1939/15 (+)	GN	SERIAL / DATA COMMUNICATION J1939 /11 / J1939/15 (-)	6	GY	LOW VOLTAGE ELECTRONIC FEED (LESS THAN 9 VOLTS)	7	RD	ALTERNATOR - RESISTANCE	8			9	GY	LOW VOLTAGE ELECTRONIC GROUND	10	WH	CHASSIS / ENGINE GROUND	11	WH	CAB / SLEEPER GROUND	12	LTBL	ACCESSORY FEED	13	PK	IGNITION FEED	BK	IGNITION FEED (BODY BUILDER CONNECTOR)	14	RD	BATTERY FEED	15	RD	KEY SWITCH FEED	16			17	PK	STARTER CONTROL	18	PK	GLOW PLUG / PRE-HEATER	19	GY	ENGINE SHUTDOWN	20	LTGN	REMOTE POWER MODULE	21	TN	COLD START CONTROLS (ETHER)	22	TN	TIRE PRESSURE MONITORING / CONTROL	23	TN	ENGINE FAN / SHUTTERS	24	GY	ENGINE EXHAUST BRAKE	25	TN	PYROMETER	26	TN	AMMETER	27	TN	VOLTMETER	28	TN	INSTRUMENTS AND GAUGES	29	TN	ENGINE WATER TEMPERATURE	30	TN	ENGINE OIL TEMPERATURE	31	TN	TRANSMISSION OIL TEMPERATURE	32	TN	AXLE OIL TEMPERATURE	33	TN	ENGINE OIL LEVEL	34	TN	COOLANT LEVEL	35	TN	ENGINE OIL PRESSURE	36	TN	FUEL LEVEL	37	TN	FUEL PUMP	38	GY	LIFT AXLE	39	GY	AIR DRYER HEATER	40	GY	LOW AIR PRESSURE WARNING	41	TN	AIR TEMPERATURE	42	GY	FRONT AXLE ENGAGED	43	GY	POWER DIVIDER LOCK (PDL) WARNING	44	GY	PARK BRAKE WARNING	45	LTGN	ANTI-THEFT WARNING
CIRCUIT NUMBER	COLOR	DESCRIPTION																																																																																																																																																			
1	LTBL	ALTERNATOR - FIELD																																																																																																																																																			
2	RD	ALTERNATOR - CHARGE																																																																																																																																																			
3	DKBL	SERIAL / DATA COMMUNICATION J1587 / J1708 (+)																																																																																																																																																			
	GY	SERIAL / DATA COMMUNICATION J1587 / J1708 (-)																																																																																																																																																			
4	DKBL	SERIAL / DATA COMMUNICATION J1922 (+)																																																																																																																																																			
	GY	SERIAL / DATA COMMUNICATION J1922 (-)																																																																																																																																																			
5	YL	SERIAL / DATA COMMUNICATION J1939 /11 / J1939/15 (+)																																																																																																																																																			
	GN	SERIAL / DATA COMMUNICATION J1939 /11 / J1939/15 (-)																																																																																																																																																			
6	GY	LOW VOLTAGE ELECTRONIC FEED (LESS THAN 9 VOLTS)																																																																																																																																																			
7	RD	ALTERNATOR - RESISTANCE																																																																																																																																																			
8																																																																																																																																																					
9	GY	LOW VOLTAGE ELECTRONIC GROUND																																																																																																																																																			
10	WH	CHASSIS / ENGINE GROUND																																																																																																																																																			
11	WH	CAB / SLEEPER GROUND																																																																																																																																																			
12	LTBL	ACCESSORY FEED																																																																																																																																																			
13	PK	IGNITION FEED																																																																																																																																																			
	BK	IGNITION FEED (BODY BUILDER CONNECTOR)																																																																																																																																																			
14	RD	BATTERY FEED																																																																																																																																																			
15	RD	KEY SWITCH FEED																																																																																																																																																			
16																																																																																																																																																					
17	PK	STARTER CONTROL																																																																																																																																																			
18	PK	GLOW PLUG / PRE-HEATER																																																																																																																																																			
19	GY	ENGINE SHUTDOWN																																																																																																																																																			
20	LTGN	REMOTE POWER MODULE																																																																																																																																																			
21	TN	COLD START CONTROLS (ETHER)																																																																																																																																																			
22	TN	TIRE PRESSURE MONITORING / CONTROL																																																																																																																																																			
23	TN	ENGINE FAN / SHUTTERS																																																																																																																																																			
24	GY	ENGINE EXHAUST BRAKE																																																																																																																																																			
25	TN	PYROMETER																																																																																																																																																			
26	TN	AMMETER																																																																																																																																																			
27	TN	VOLTMETER																																																																																																																																																			
28	TN	INSTRUMENTS AND GAUGES																																																																																																																																																			
29	TN	ENGINE WATER TEMPERATURE																																																																																																																																																			
30	TN	ENGINE OIL TEMPERATURE																																																																																																																																																			
31	TN	TRANSMISSION OIL TEMPERATURE																																																																																																																																																			
32	TN	AXLE OIL TEMPERATURE																																																																																																																																																			
33	TN	ENGINE OIL LEVEL																																																																																																																																																			
34	TN	COOLANT LEVEL																																																																																																																																																			
35	TN	ENGINE OIL PRESSURE																																																																																																																																																			
36	TN	FUEL LEVEL																																																																																																																																																			
37	TN	FUEL PUMP																																																																																																																																																			
38	GY	LIFT AXLE																																																																																																																																																			
39	GY	AIR DRYER HEATER																																																																																																																																																			
40	GY	LOW AIR PRESSURE WARNING																																																																																																																																																			
41	TN	AIR TEMPERATURE																																																																																																																																																			
42	GY	FRONT AXLE ENGAGED																																																																																																																																																			
43	GY	POWER DIVIDER LOCK (PDL) WARNING																																																																																																																																																			
44	GY	PARK BRAKE WARNING																																																																																																																																																			
45	LTGN	ANTI-THEFT WARNING																																																																																																																																																			
CHK	DATE	CHANGE	REV	REFERENCE	DRAWN	NAME																																																																																																																																															
		REVISED AND REDRAWN	B	61000T	U00K640	CIRCUIT DIAGRAM, 42/43/44/85/8600 & 73/74/7500																																																																																																																																															
					RELEASE NO. 59974G	DATE 20APR06																																																																																																																																															
						PART NO. AE08056608																																																																																																																																															
						SHEET 004																																																																																																																																															

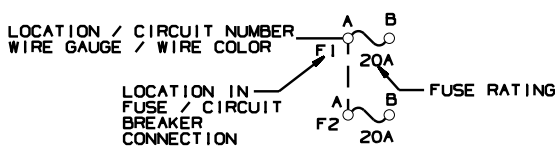
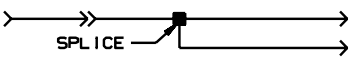
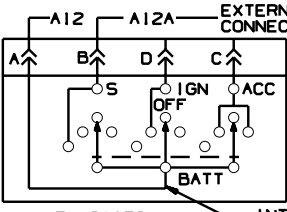
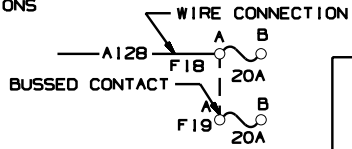
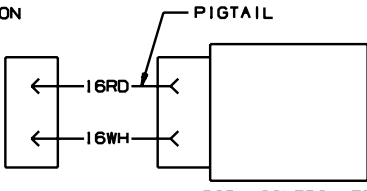
Figure 4 Circuit Number Identification and Color

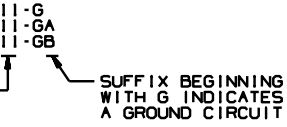
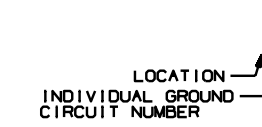
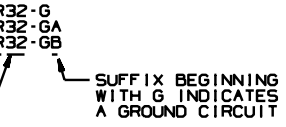
2.5. CIRCUIT NUMBER IDENTIFICATION AND COLOR, P. 5

CIRCUIT NUMBER	COLOR	DESCRIPTION
46	GY	POWER TAKE-OFF WARNING
47	GY	SPEEDOMETER
48	GY	TACHOMETER
49	GY	DIFFERENTIAL LOCK WARNING
50	YL	LIGHT SWITCH FEED
51	YL	DIMMER SWITCH FEED
52	YL	HEADLIGHT HI - BEAM
53	YL	HEADLIGHT LO - BEAM
54	BN	PARKING / MARKER LIGHTS
55	OR	TURN SIGNAL - FEED
56	OR	TURN SIGNAL LIGHTS - LEFT
	YL	TURN SIGNAL LIGHTS - LEFT (BODY BUILDER CONNECTION)
57	OR	TURN SIGNAL LIGHTS - RIGHT
	LTGN	TURN SIGNAL LIGHTS - RIGHT (BODY BUILDER CONNECTION)
58	BN	CLEARANCE / IDENTIFICATION LIGHTS
59	GY	SOLENOID
60	OR	HAZARD LIGHTS
61	GY	AIR SUSPENSION
62	DKBL	PANEL LIGHTS
63	DKBL	COURTESY / DOME LIGHTS
64	YL	FOG / DRIVING LIGHTS
65	OR	CAB REAR FLOOD LIGHTS
66	YL	DAYTIME RUNNING LIGHTS
67	GY	OBSTACLE AVOIDANCE / REMOTE SENSOR
68	BN	TAIL LIGHTS
69	BN	LICENSE PLATE LIGHT
70	OR	STOP LIGHTS
	RD	STOP LIGHTS (BODY BUILDER CONNECTION)
71	OR	BACK-UP LIGHTS
	LTBL	BACK-UP LIGHTS (BODY BUILDER CONNECTION)
72	OR	TRAILER AUXILIARY FEED - BATTERY
73	LTGN	PWM
74	LTGN	HEATER RECIRCULATION MOTOR
75	LTGN	HEATER BLOWER MOTOR
76	LTGN	AUXILIARY FAN
77	LTGN	AIR CONDITIONER
78	LTGN	MIRRORS - HEATED, MOTORIZED
79	GY	SEAT BELTS
80	BK	SLEEPER BOX RELAY - FEED
81	LTGN	POWER DOOR LOCKS
82	GY	WINDSHIELD WIPER
83	LTGN	POWER WINDOWS
84	LTGN	CIGAR LIGHTER
85	GY	HORN

CHK	DATE	CHANGE	REV	REFERENCE	DRAWN	NAME
RAW6	04DEC07	REVISED AND REDRAWN	B	61000T	U00K640	CIRCUIT DIAGRAM, 42/43/44/85/8600 & 73/74/7500
					RELEASE NO.	DATE
					59974G	12SEP06
						PART NO.
						AE08056608
						SHEET
						005

Figure 5 Circuit Number Identification and Color (Cont.)

2.6. CIRCUIT NUMBER IDENTIFICATION AND COLOR, P. 6

INTERNATIONAL TRUCK AND ENGINE CORPORATION		ELECTRICAL CIRCUIT DIAGRAM CHAPTER 2																																																																																																																													
THIS PRINT IS PROVIDED ON A RESTRICTED BASIS AND IS NOT TO BE USED IN ANY WAY DETRIMENTAL TO THE INTEREST OF INTERNATIONAL TRUCK AND ENGINE CORPORATION.		CIRCUIT NUMBER IDENTIFICATION AND COLOR (CONT)																																																																																																																													
<table border="1" style="width: 100%; border-collapse: collapse;"> <thead> <tr> <th style="width: 15%;">CIRCUIT NUMBER</th> <th style="width: 15%;">COLOR</th> <th style="width: 70%;">DESCRIPTION</th> </tr> </thead> <tbody> <tr><td>86</td><td>LTGN</td><td>RADIO - ENTERTAINMENT</td></tr> <tr><td>87</td><td>GY</td><td>WINDSHIELD WASHER</td></tr> <tr><td>88</td><td>LTGN</td><td>CLOCK / HOURMETER</td></tr> <tr><td>89</td><td>VT</td><td>AIR BAG</td></tr> <tr><td>90</td><td>GY</td><td>HYDRAULIC BRAKE PUMP</td></tr> <tr><td>91</td><td>VT</td><td>INTERCOMMUNICATIONS</td></tr> <tr><td>92</td><td>TN</td><td>TRANSMISSION CONTROLS - ELECTRONIC</td></tr> <tr><td>93</td><td>TN</td><td>AXLE SHIFT CONTROL</td></tr> <tr><td>94</td><td>GY</td><td>ANTILOCK BRAKE SYSTEM</td></tr> <tr><td>95</td><td>TN</td><td>EXHAUST EMISSION</td></tr> <tr><td>96</td><td>YL</td><td>SNOW PLOW LIGHTS / CRUISE CONTROLS</td></tr> <tr><td>97</td><td>VT</td><td>ENGINE CONTROLS - ELECTRONIC</td></tr> <tr><td>98</td><td>BK</td><td>DATALINK AND DIAGNOSTICS</td></tr> <tr><td>99</td><td>VT</td><td>ACCELERATOR POSITION SENSOR (APS)</td></tr> <tr><td>100</td><td>GY</td><td>AIR HORN (ELECTRIC SOLENOID ACTUATED)</td></tr> <tr><td>101</td><td>TN</td><td>BRAKE APPLICATION AIR</td></tr> <tr><td>102</td><td>YL</td><td>FLASH TO PASS</td></tr> <tr><td>103</td><td>LTGN</td><td>BODY BUILDER AUXILIARY FEED</td></tr> <tr><td>104</td><td>DKBL</td><td>REMOTE START / STOP</td></tr> <tr><td>105</td><td>LTGN</td><td>HEATED SEATS</td></tr> <tr><td>106</td><td>OR</td><td>HIGH VOLTAGE ALTERNATOR AC CHARGE</td></tr> <tr><td>107</td><td>GY</td><td>INSTRUMENT CLUSTER ELECTRONIC FEED (5V)</td></tr> <tr><td>108</td><td>GY</td><td>BRAKE PAD WEAR SENSOR</td></tr> <tr><td>109</td><td>GY</td><td>SLACK ADJUSTER</td></tr> <tr><td>110</td><td>GY</td><td>INSTRUMENT CLUSTER ELECTRONIC GROUND</td></tr> <tr><td>111</td><td>TN</td><td>FUEL FILTER RESTRICTION TRANSDUCERS</td></tr> <tr><td>112</td><td>GY</td><td>LIFT GATE</td></tr> </tbody> </table> <table border="1" style="width: 100%; border-collapse: collapse;"> <thead> <tr> <th style="width: 15%;">PREFIX</th> <th style="width: 85%;">LOCATION</th> </tr> </thead> <tbody> <tr><td>A</td><td>CAB - INSTRUMENT PANEL MODULE</td></tr> <tr><td>B</td><td>CAB - DRIVER CONTROL MODULE</td></tr> <tr><td>C</td><td>CAB - HEADER / CLEARANCE LIGHTS</td></tr> <tr><td>D</td><td>CAB - ROOF / REAR PANEL</td></tr> <tr><td>E</td><td>CAB - LEFT DOOR / DOORS</td></tr> <tr><td>F</td><td>CAB - RIGHT DOOR / DOORS</td></tr> <tr><td>H</td><td>CAB - SLEEPER</td></tr> <tr><td>J</td><td>CAB - DASH (OUTSIDE)</td></tr> <tr><td>K</td><td>ENGINE / RADIATOR</td></tr> <tr><td>L</td><td>TRANSMISSION</td></tr> <tr><td>M</td><td>CHASSIS / FRONT END (CAB DASH PANEL FORWARD)</td></tr> <tr><td>N</td><td>CHASSIS - CENTER SECTION (CAB DASH PANEL TO CAB REAR CROSS MEMBER)</td></tr> <tr><td>P</td><td>CHASSIS - WHEEL BASE SECTION</td></tr> <tr><td>R</td><td>CHASSIS - SUSPENSION / REAR AXLE / AXLES</td></tr> <tr><td>S</td><td>CHASSIS - AF SECTION / STOP / TAIL / TURN LIGHTS</td></tr> <tr><td>T</td><td>TRAVEL DOORS</td></tr> <tr><td>U</td><td>HOOD MTD HEADLIGHTS / MARKER LIGHTS</td></tr> <tr><td>V</td><td>SLEEPER ROOF / BACK PANEL WIRING</td></tr> <tr><td>W</td><td>WARDROBE CABINET WIRING</td></tr> </tbody> </table>				CIRCUIT NUMBER	COLOR	DESCRIPTION	86	LTGN	RADIO - ENTERTAINMENT	87	GY	WINDSHIELD WASHER	88	LTGN	CLOCK / HOURMETER	89	VT	AIR BAG	90	GY	HYDRAULIC BRAKE PUMP	91	VT	INTERCOMMUNICATIONS	92	TN	TRANSMISSION CONTROLS - ELECTRONIC	93	TN	AXLE SHIFT CONTROL	94	GY	ANTILOCK BRAKE SYSTEM	95	TN	EXHAUST EMISSION	96	YL	SNOW PLOW LIGHTS / CRUISE CONTROLS	97	VT	ENGINE CONTROLS - ELECTRONIC	98	BK	DATALINK AND DIAGNOSTICS	99	VT	ACCELERATOR POSITION SENSOR (APS)	100	GY	AIR HORN (ELECTRIC SOLENOID ACTUATED)	101	TN	BRAKE APPLICATION AIR	102	YL	FLASH TO PASS	103	LTGN	BODY BUILDER AUXILIARY FEED	104	DKBL	REMOTE START / STOP	105	LTGN	HEATED SEATS	106	OR	HIGH VOLTAGE ALTERNATOR AC CHARGE	107	GY	INSTRUMENT CLUSTER ELECTRONIC FEED (5V)	108	GY	BRAKE PAD WEAR SENSOR	109	GY	SLACK ADJUSTER	110	GY	INSTRUMENT CLUSTER ELECTRONIC GROUND	111	TN	FUEL FILTER RESTRICTION TRANSDUCERS	112	GY	LIFT GATE	PREFIX	LOCATION	A	CAB - INSTRUMENT PANEL MODULE	B	CAB - DRIVER CONTROL MODULE	C	CAB - HEADER / CLEARANCE LIGHTS	D	CAB - ROOF / REAR PANEL	E	CAB - LEFT DOOR / DOORS	F	CAB - RIGHT DOOR / DOORS	H	CAB - SLEEPER	J	CAB - DASH (OUTSIDE)	K	ENGINE / RADIATOR	L	TRANSMISSION	M	CHASSIS / FRONT END (CAB DASH PANEL FORWARD)	N	CHASSIS - CENTER SECTION (CAB DASH PANEL TO CAB REAR CROSS MEMBER)	P	CHASSIS - WHEEL BASE SECTION	R	CHASSIS - SUSPENSION / REAR AXLE / AXLES	S	CHASSIS - AF SECTION / STOP / TAIL / TURN LIGHTS	T	TRAVEL DOORS	U	HOOD MTD HEADLIGHTS / MARKER LIGHTS	V	SLEEPER ROOF / BACK PANEL WIRING	W	WARDROBE CABINET WIRING
CIRCUIT NUMBER	COLOR	DESCRIPTION																																																																																																																													
86	LTGN	RADIO - ENTERTAINMENT																																																																																																																													
87	GY	WINDSHIELD WASHER																																																																																																																													
88	LTGN	CLOCK / HOURMETER																																																																																																																													
89	VT	AIR BAG																																																																																																																													
90	GY	HYDRAULIC BRAKE PUMP																																																																																																																													
91	VT	INTERCOMMUNICATIONS																																																																																																																													
92	TN	TRANSMISSION CONTROLS - ELECTRONIC																																																																																																																													
93	TN	AXLE SHIFT CONTROL																																																																																																																													
94	GY	ANTILOCK BRAKE SYSTEM																																																																																																																													
95	TN	EXHAUST EMISSION																																																																																																																													
96	YL	SNOW PLOW LIGHTS / CRUISE CONTROLS																																																																																																																													
97	VT	ENGINE CONTROLS - ELECTRONIC																																																																																																																													
98	BK	DATALINK AND DIAGNOSTICS																																																																																																																													
99	VT	ACCELERATOR POSITION SENSOR (APS)																																																																																																																													
100	GY	AIR HORN (ELECTRIC SOLENOID ACTUATED)																																																																																																																													
101	TN	BRAKE APPLICATION AIR																																																																																																																													
102	YL	FLASH TO PASS																																																																																																																													
103	LTGN	BODY BUILDER AUXILIARY FEED																																																																																																																													
104	DKBL	REMOTE START / STOP																																																																																																																													
105	LTGN	HEATED SEATS																																																																																																																													
106	OR	HIGH VOLTAGE ALTERNATOR AC CHARGE																																																																																																																													
107	GY	INSTRUMENT CLUSTER ELECTRONIC FEED (5V)																																																																																																																													
108	GY	BRAKE PAD WEAR SENSOR																																																																																																																													
109	GY	SLACK ADJUSTER																																																																																																																													
110	GY	INSTRUMENT CLUSTER ELECTRONIC GROUND																																																																																																																													
111	TN	FUEL FILTER RESTRICTION TRANSDUCERS																																																																																																																													
112	GY	LIFT GATE																																																																																																																													
PREFIX	LOCATION																																																																																																																														
A	CAB - INSTRUMENT PANEL MODULE																																																																																																																														
B	CAB - DRIVER CONTROL MODULE																																																																																																																														
C	CAB - HEADER / CLEARANCE LIGHTS																																																																																																																														
D	CAB - ROOF / REAR PANEL																																																																																																																														
E	CAB - LEFT DOOR / DOORS																																																																																																																														
F	CAB - RIGHT DOOR / DOORS																																																																																																																														
H	CAB - SLEEPER																																																																																																																														
J	CAB - DASH (OUTSIDE)																																																																																																																														
K	ENGINE / RADIATOR																																																																																																																														
L	TRANSMISSION																																																																																																																														
M	CHASSIS / FRONT END (CAB DASH PANEL FORWARD)																																																																																																																														
N	CHASSIS - CENTER SECTION (CAB DASH PANEL TO CAB REAR CROSS MEMBER)																																																																																																																														
P	CHASSIS - WHEEL BASE SECTION																																																																																																																														
R	CHASSIS - SUSPENSION / REAR AXLE / AXLES																																																																																																																														
S	CHASSIS - AF SECTION / STOP / TAIL / TURN LIGHTS																																																																																																																														
T	TRAVEL DOORS																																																																																																																														
U	HOOD MTD HEADLIGHTS / MARKER LIGHTS																																																																																																																														
V	SLEEPER ROOF / BACK PANEL WIRING																																																																																																																														
W	WARDROBE CABINET WIRING																																																																																																																														
CHK	DATE	CHANGE	REV	REFERENCE	DRAWN	NAME																																																																																																																									
RAW6	04DEC07	REVISED AND REDRAWN	B	61000T	U00K640	CIRCUIT DIAGRAM, 42/43/44/85/8600 & 73/74/7500																																																																																																																									
					RELEASE NO.	DATE	PART NO.																																																																																																																								
					59974G	12SEP06	AE08056608																																																																																																																								
							SHEET 006																																																																																																																								

Figure 6 Circuit Number Identification and Color (Cont.)

2.7. LAMP BULB CHART, P. 7

INTERNATIONAL TRUCK AND ENGINE CORPORATION				ELECTRICAL CIRCUIT DIAGRAM		CHAPTER 2																																								
THIS PRINT IS PROVIDED ON A RESTRICTED BASIS AND IS NOT TO BE USED IN ANY WAY DETRIMENTAL TO THE INTEREST OF INTERNATIONAL TRUCK AND ENGINE CORPORATION.				LAMP BULB CHART																																										
<table border="1" style="width: 100%; border-collapse: collapse;"> <thead> <tr> <th style="width: 50%;">BULB APPLICATION</th> <th style="width: 25%;">CANDLEPOWER OR WATT</th> <th style="width: 25%;">BULB TRADE NUMBER</th> </tr> </thead> <tbody> <tr><td>BACK - UP LIGHTS</td><td>32 CP</td><td>GE1156</td></tr> <tr><td>CLEARANCE & IDENTIFICATION</td><td>3 CP</td><td>GE193</td></tr> <tr><td>COURTESY LIGHT</td><td>3CP</td><td>GE168</td></tr> <tr><td>FOG LIGHTS</td><td>55 WATTS</td><td>VH550</td></tr> <tr><td>LOW BEAMS</td><td>65 WATTS</td><td>GE9007</td></tr> <tr><td>HIGH BEAMS</td><td>65 WATTS</td><td>GE9007</td></tr> <tr><td>MAP LIGHT</td><td>3 CP</td><td>1816</td></tr> <tr><td>SIDE MARKER</td><td></td><td>2548</td></tr> <tr><td>STOP & TURN / TAIL & LICENSE PLATE</td><td>32/3 CP</td><td>1157</td></tr> <tr><td>TURN SIGNAL / MARKER (FENDER)</td><td></td><td>3157</td></tr> <tr><td>TURN SIGNAL & MARKER LIGHT</td><td></td><td>2356</td></tr> <tr><td>WORK (TRAILER HOOK - UP)</td><td>35 WATTS</td><td>4411</td></tr> </tbody> </table>								BULB APPLICATION	CANDLEPOWER OR WATT	BULB TRADE NUMBER	BACK - UP LIGHTS	32 CP	GE1156	CLEARANCE & IDENTIFICATION	3 CP	GE193	COURTESY LIGHT	3CP	GE168	FOG LIGHTS	55 WATTS	VH550	LOW BEAMS	65 WATTS	GE9007	HIGH BEAMS	65 WATTS	GE9007	MAP LIGHT	3 CP	1816	SIDE MARKER		2548	STOP & TURN / TAIL & LICENSE PLATE	32/3 CP	1157	TURN SIGNAL / MARKER (FENDER)		3157	TURN SIGNAL & MARKER LIGHT		2356	WORK (TRAILER HOOK - UP)	35 WATTS	4411
BULB APPLICATION	CANDLEPOWER OR WATT	BULB TRADE NUMBER																																												
BACK - UP LIGHTS	32 CP	GE1156																																												
CLEARANCE & IDENTIFICATION	3 CP	GE193																																												
COURTESY LIGHT	3CP	GE168																																												
FOG LIGHTS	55 WATTS	VH550																																												
LOW BEAMS	65 WATTS	GE9007																																												
HIGH BEAMS	65 WATTS	GE9007																																												
MAP LIGHT	3 CP	1816																																												
SIDE MARKER		2548																																												
STOP & TURN / TAIL & LICENSE PLATE	32/3 CP	1157																																												
TURN SIGNAL / MARKER (FENDER)		3157																																												
TURN SIGNAL & MARKER LIGHT		2356																																												
WORK (TRAILER HOOK - UP)	35 WATTS	4411																																												
CHK	DATE	CHANGE	REV	REFERENCE	DRAWN	NAME																																								
					U00K640	42/43/44/85/8600 & 73/74/7500 CIRC DIAGRAMS																																								
					RELEASE NO.	DATE	PART NO. SHEET																																							
					59974G	20APR06	AF08-56608 07																																							

Figure 7 Lamp Bulb Chart

2.8. RELAY FUNCTION AND WIRING GUIDE, P. 8

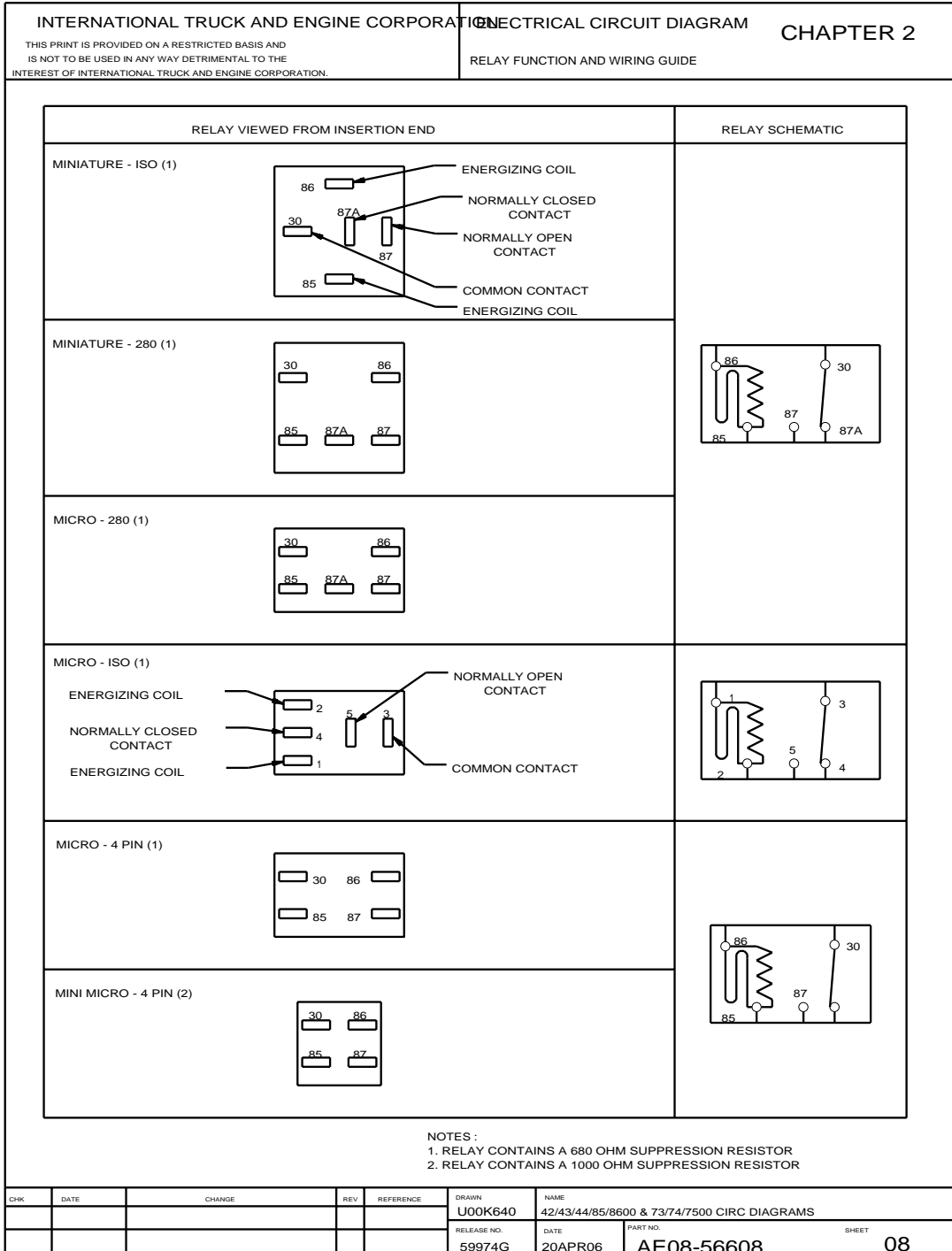

Figure 8 Relay Function and Wiring Guide

2.9. SCHEMATIC SYMBOL CHART, P. 9





INTERNATIONAL TRUCK AND ENGINE CORPORATION <small>THIS PRINT IS PROVIDED ON A RESTRICTED BASIS AND IS NOT TO BE USED IN ANY WAY DETRIMENTAL TO THE INTEREST OF INTERNATIONAL TRUCK AND ENGINE CORPORATION.</small>				ELECTRICAL CIRCUIT DIAGRAM CHAPTER 2 SCHEMATIC SYMBOL CHART																				
SYMBOL	DESCRIPTION	SYMBOL	DESCRIPTION																					
	ACCEL PEDAL POSN SENSOR		AMMETER																					
	ACCEL PEDAL POSN SENSOR		BATTERY																					
	AIR DRYER		BLUNT CUT CIRCUIT																					
	ALARM		BUSBAR																					
	ALTERNATOR		CIGAR LIGHTER																					
		TYPE 1  TYPE 2 OR 3 	CIRCUIT BREAKER																					
			DIODE																					
<table border="1" style="width: 100%; border-collapse: collapse;"> <tr> <th style="width: 10%;">CHK</th> <th style="width: 10%;">DATE</th> <th style="width: 20%;">CHANGE</th> <th style="width: 10%;">REV</th> <th style="width: 10%;">REFERENCE</th> <th style="width: 10%;">DRAWN</th> <th style="width: 30%;">NAME</th> </tr> <tr> <td>CNA</td> <td>9MAY07</td> <td>ADDED SYMBOL FOR</td> <td>A</td> <td>60782A</td> <td>U00K640</td> <td>42/43/44/85/8600 & 73/74/7500 CIRC DIAGRAMS</td> </tr> <tr> <td></td> <td></td> <td>ACCEL PEDAL POSN SNSR</td> <td></td> <td></td> <td>RELEASE NO. 59974G</td> <td>DATE 12SEP06 PART NO. AE08-56608 SHEET 09</td> </tr> </table>	CHK	DATE	CHANGE	REV	REFERENCE	DRAWN	NAME	CNA	9MAY07	ADDED SYMBOL FOR	A	60782A	U00K640	42/43/44/85/8600 & 73/74/7500 CIRC DIAGRAMS			ACCEL PEDAL POSN SNSR			RELEASE NO. 59974G	DATE 12SEP06 PART NO. AE08-56608 SHEET 09			
CHK	DATE	CHANGE	REV	REFERENCE	DRAWN	NAME																		
CNA	9MAY07	ADDED SYMBOL FOR	A	60782A	U00K640	42/43/44/85/8600 & 73/74/7500 CIRC DIAGRAMS																		
		ACCEL PEDAL POSN SNSR			RELEASE NO. 59974G	DATE 12SEP06 PART NO. AE08-56608 SHEET 09																		

Figure 9 Schematic Symbol Chart

2.10. SCHEMATIC SYMBOL CHART, P. 10

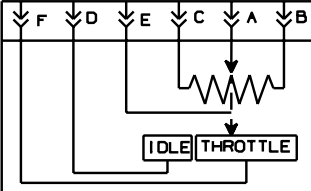
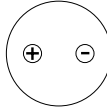
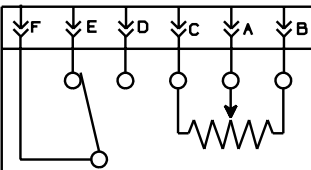
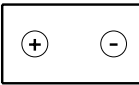
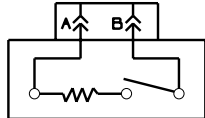
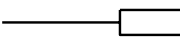
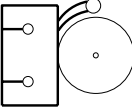
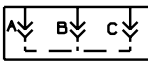
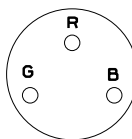
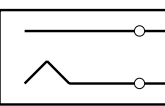







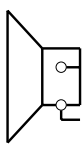
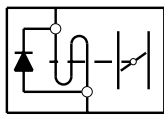

INTERNATIONAL TRUCK AND ENGINE CORPORATION <small>THIS PRINT IS PROVIDED ON A RESTRICTED BASIS AND IS NOT TO BE USED IN ANY WAY DETRIMENTAL TO THE INTEREST OF INTERNATIONAL TRUCK AND ENGINE CORPORATION.</small>				ELECTRICAL CIRCUIT DIAGRAM CHAPTER 2 SCHEMATIC SYMBOL CHART (CONT)																																											
	DIODE, LIGHT EMITTING		HORN		FAN SOLENOID																																										
	FEMALE TERMINAL		KEY SWITCH		FUSE																																										
	FUSIBLE LINK		KEY SWITCH, COMPLEX		FUSES W/ BUSBAR																																										
	GROUND N/ STUD		LIGHT W/ SWITCH		GROUND N/ STUD																																										
	HEATER		LIGHT, DOUBLE FILAMENT		HEATER																																										
	HOLDER, FUSE W/ BUSBAR		LIGHT, SINGLE FILAMENT		HOLDER, FUSE W/ BUSBAR																																										
<table border="1"> <tr> <th>CHR</th> <th>DATE</th> <th>CHANGE</th> <th>REV</th> <th>REFERENCE</th> <th>DRAWN</th> <th>NAME</th> </tr> <tr> <td>CNA</td> <td>0MAY07</td> <td>REVISED & REDRAWN</td> <td>A</td> <td>60782A</td> <td>U00K640</td> <td>42/43/44/85/8600 & 73/74/7500 CIRC DIAGRAMS</td> </tr> <tr> <td></td> <td></td> <td></td> <td></td> <td></td> <td>RELEASE NO.</td> <td>DATE</td> </tr> <tr> <td></td> <td></td> <td></td> <td></td> <td></td> <td>59974G</td> <td>12SEP06</td> </tr> <tr> <td></td> <td></td> <td></td> <td></td> <td></td> <td>PART NO.</td> <td>SHEET</td> </tr> <tr> <td></td> <td></td> <td></td> <td></td> <td></td> <td>AE08-56608</td> <td>10</td> </tr> </table>	CHR	DATE	CHANGE	REV	REFERENCE	DRAWN	NAME	CNA	0MAY07	REVISED & REDRAWN	A	60782A	U00K640	42/43/44/85/8600 & 73/74/7500 CIRC DIAGRAMS						RELEASE NO.	DATE						59974G	12SEP06						PART NO.	SHEET						AE08-56608	10					
CHR	DATE	CHANGE	REV	REFERENCE	DRAWN	NAME																																									
CNA	0MAY07	REVISED & REDRAWN	A	60782A	U00K640	42/43/44/85/8600 & 73/74/7500 CIRC DIAGRAMS																																									
					RELEASE NO.	DATE																																									
					59974G	12SEP06																																									
					PART NO.	SHEET																																									
					AE08-56608	10																																									

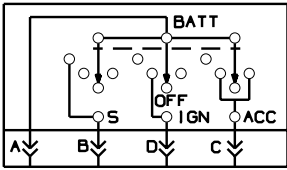
Figure 10 Schematic Symbol Chart (Cont.)

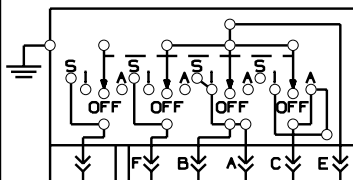
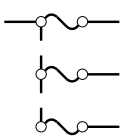
2.11. SCHEMATIC SYMBOL CHART, P. 11

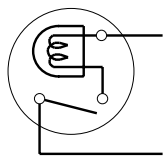
INTERNATIONAL TRUCK AND ENGINE CORPORATION <small>THIS PRINT IS PROVIDED ON A RESTRICTED BASIS AND IS NOT TO BE USED IN ANY WAY DETRIMENTAL TO THE INTEREST OF INTERNATIONAL TRUCK AND ENGINE CORPORATION.</small>				ELECTRICAL CIRCUIT DIAGRAM CHAPTER 2 SCHEMATIC SYMBOL CHART (CONT.)	
	SYMBOL	DESCRIPTION		SYMBOL	DESCRIPTION
→		MALE TERMINAL	——		RESISTOR
		MOTOR			SENDER - FUEL, OIL, TEMP, WATER
		PASS THRU CONNECTION			SENSOR, PRESSURE, ABS 6
		PRESSURE SWITCH			SENSOR, MAGNETIC
		RELAY, FIVE TERMINAL			SENSOR, YAW
		RELAY, FOUR TERMINAL			SOLENOID
		RELAY, LATCHING			SOLENOID W/ DIODE

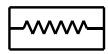
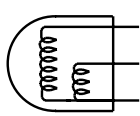
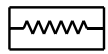
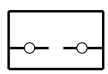
CHR	DATE	CHANGE	REV	REFERENCE	DWRN	NAME
CNA	9MAY07	REVISED & REDRAWN	A	60782A	U00K640	42/43/44/85/8600 & 73/74/7500 CIRC DIAGRAMS
					RELEASE NO.	DATE
					59974G	20APR06
					PART NO.	SHEET
					AE08-56608	11

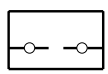
Figure 11 Schematic Symbol Chart (Cont.)

2.12. SCHEMATIC SYMBOL CHART, P.12

INTERNATIONAL TRUCK AND ENGINE CORPORATION				ELECTRICAL CIRCUIT DIAGRAM CHAPTER 2			
THIS PRINT IS PROVIDED ON A RESTRICTED BASIS AND IS NOT TO BE USED IN ANY WAY DETRIMENTAL TO THE INTEREST OF INTERNATIONAL TRUCK AND ENGINE CORPORATION.				SCHEMATIC SYMBOL CHART (CONT)			
SYMBOL		DESCRIPTION		SYMBOL		DESCRIPTION	
		SPEAKER				SWITCH, PUSH BUTTON	
		SPLICE				TERMINATING RESISTOR	
		STUD				THERMISTOR	
		START MOTOR W/ TOCP				THERMOSTAT	
		SWITCH, MECHANICAL (NORMALLY OPEN)				VALVE, ETHER BOTTLE	
		SWITCH, MECHANICAL (NORMALLY CLOSED)				VALVE, MODULATOR	
CHK	DATE	CHANGE	REV	REFERENCE	DRAWN	NAME	
RAW6	04DEC07	REVISED START MOTOR	B	61000T	U00K640	CIRCUIT DIAGRAM, 42/43/44/85/8600 & 73/74/7500	
	SYMBOL				RELEASE NO.	DATE	PART NO.
					59974G	20APR06	AE08056608
						SHEET	012

Figure 12 Schematic Symbol Chart (Cont.)

3. 12 VOLT POWER DISTRIBUTION, GROUNDS, DATA BUS AND ELECTRICAL SYSTEM CONTROLLER (CHAPTER 3)

3.1. BATTERY FEED, P. 1

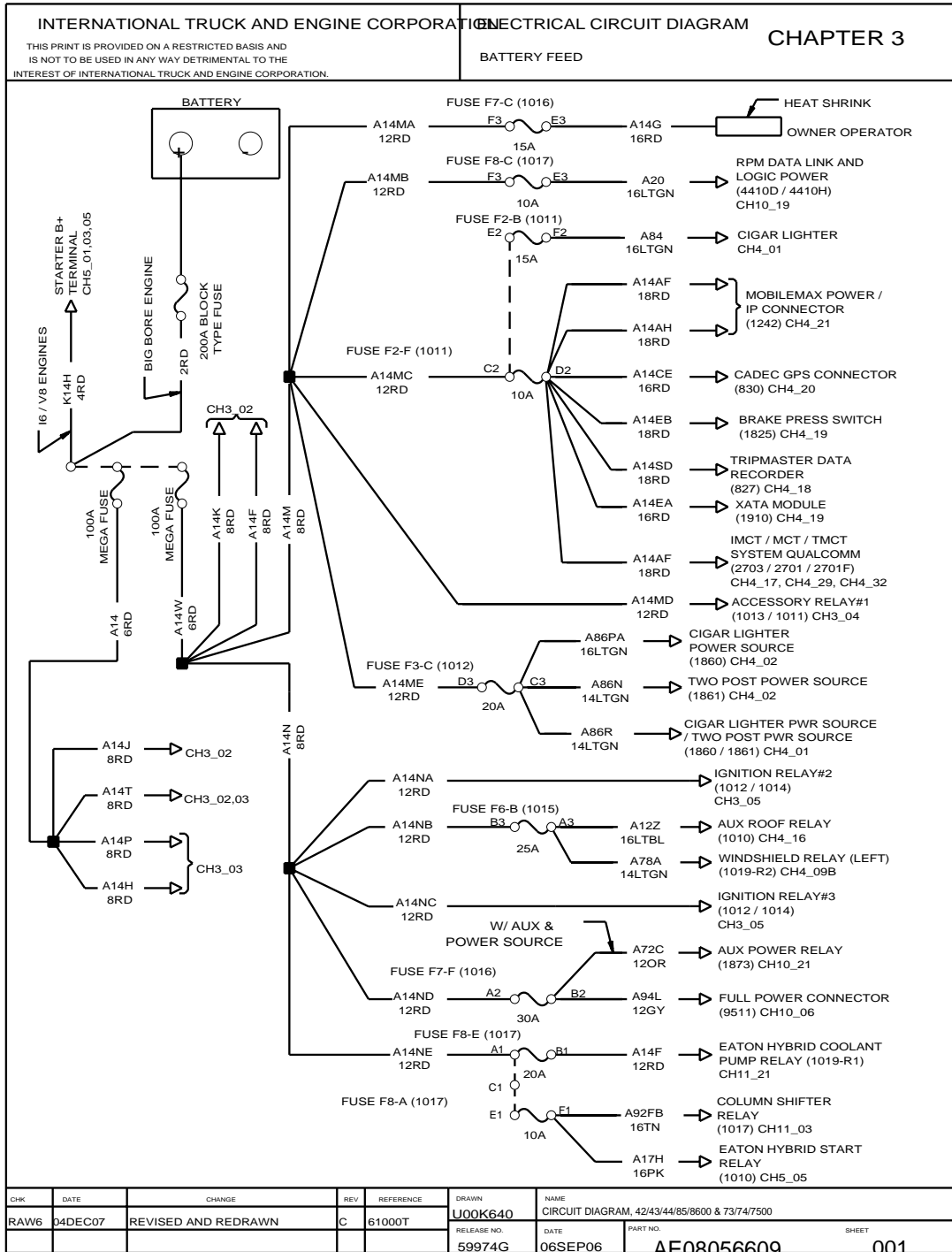

Figure 13 Battery Feed

3.2. BATTERY FEED, P. 2

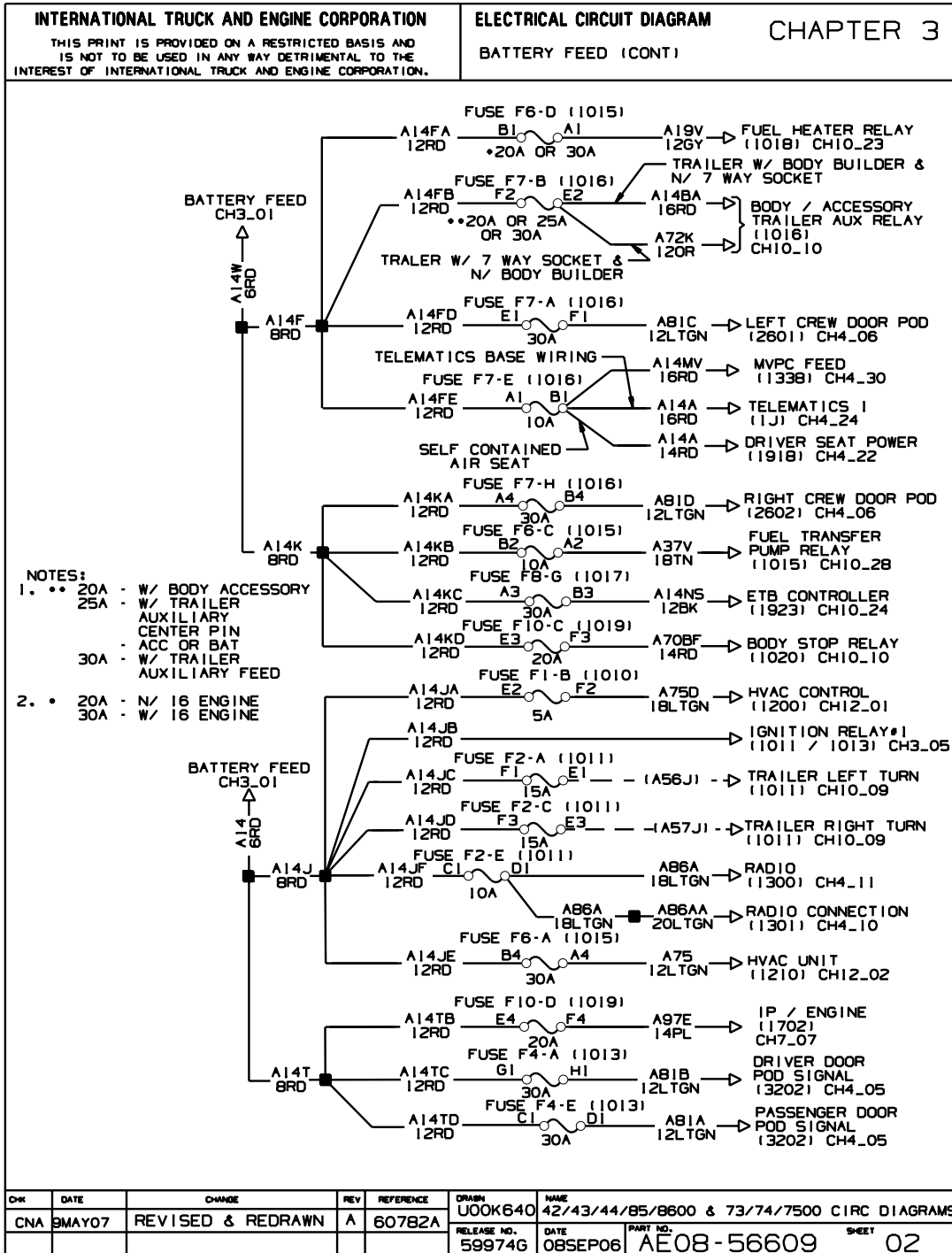

Figure 14 Battery Feeds (Cont.)

3.3. BATTERY FEED, P. 3

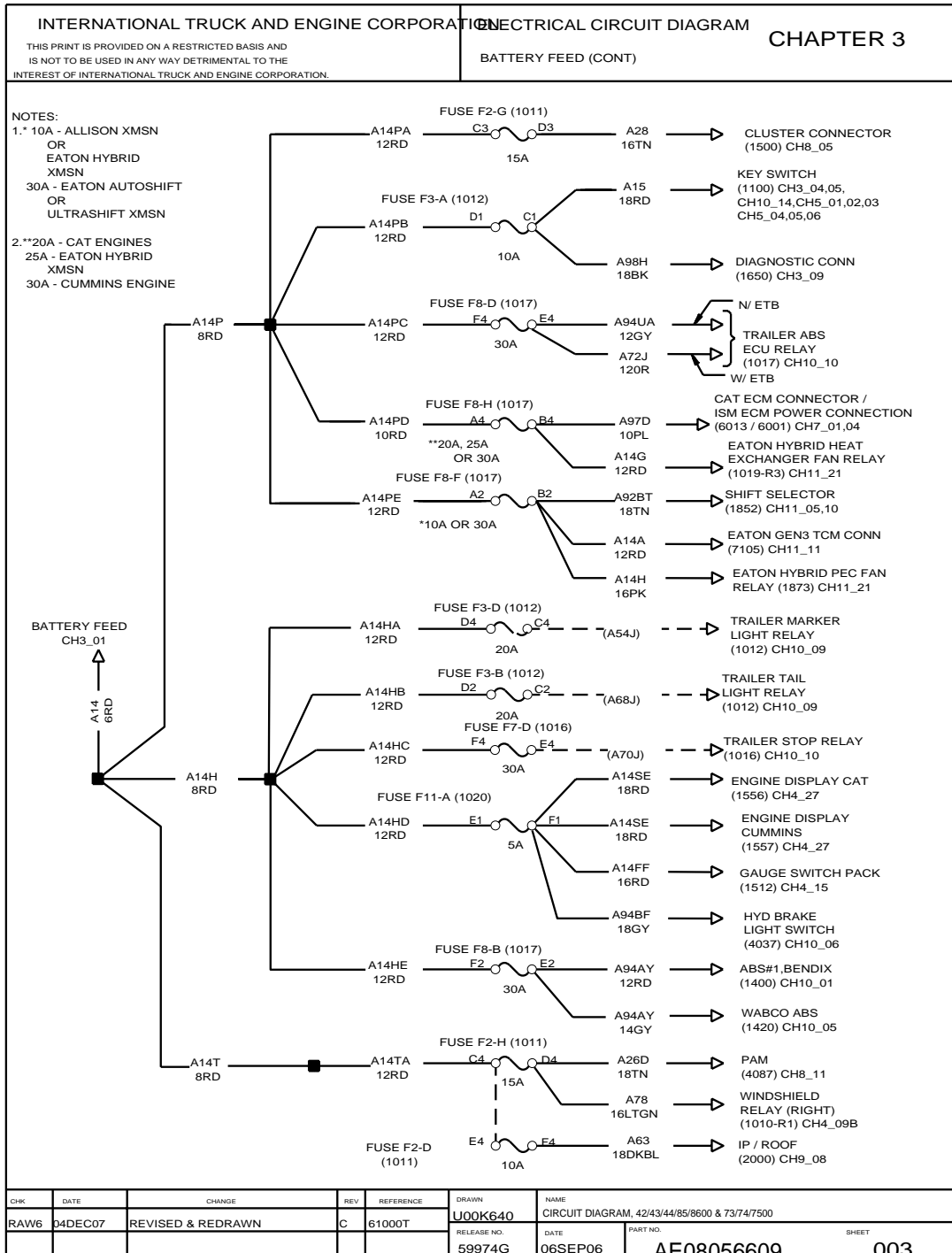

Figure 15 Battery Feed (Cont.)

3.4. ACCESSORY FEED, P. 4

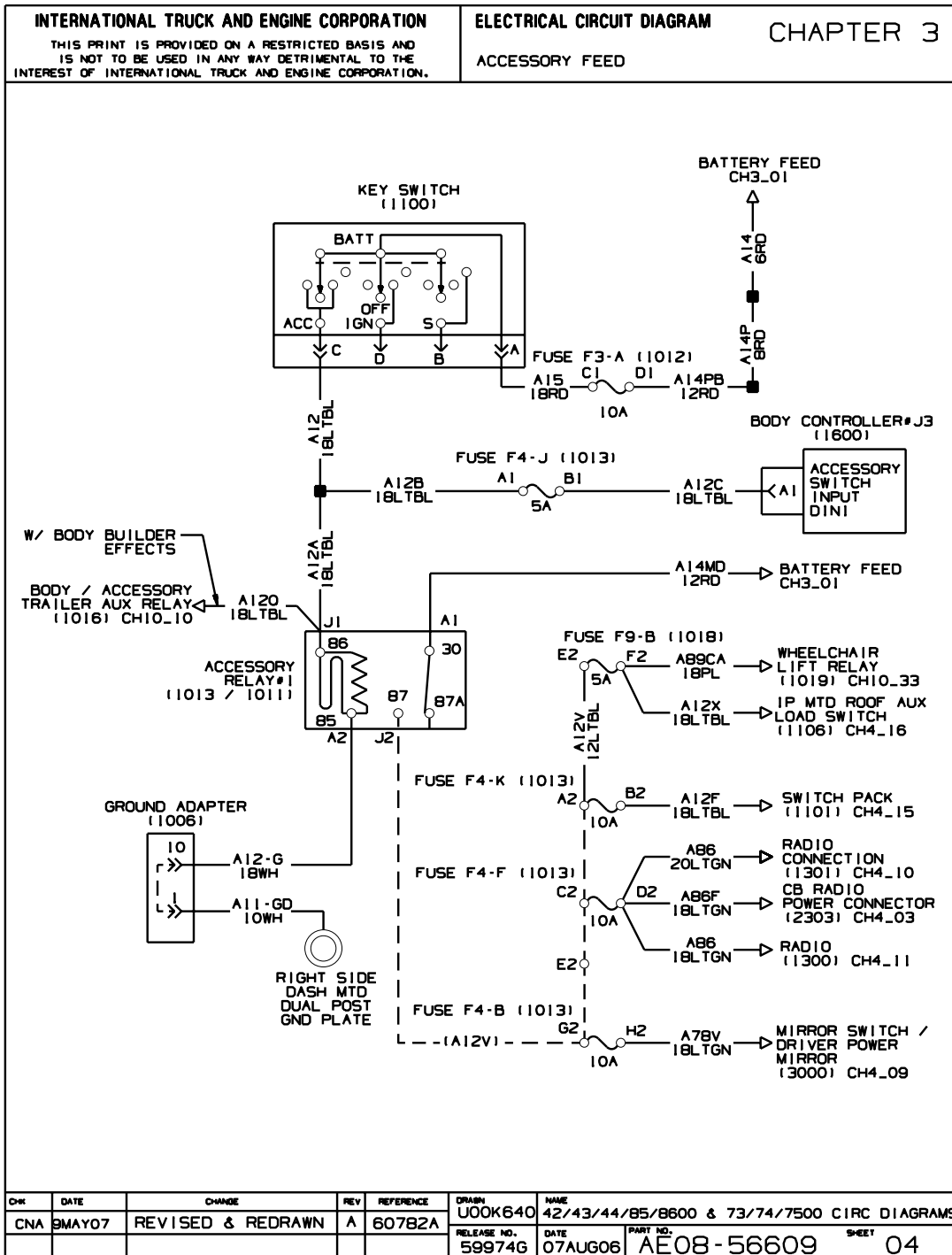

Figure 16 Accessory Feed

3.5. IGNITION FEED — STANDARD, THEFT DETERRENT, REMOTE START/STOP, P. 5

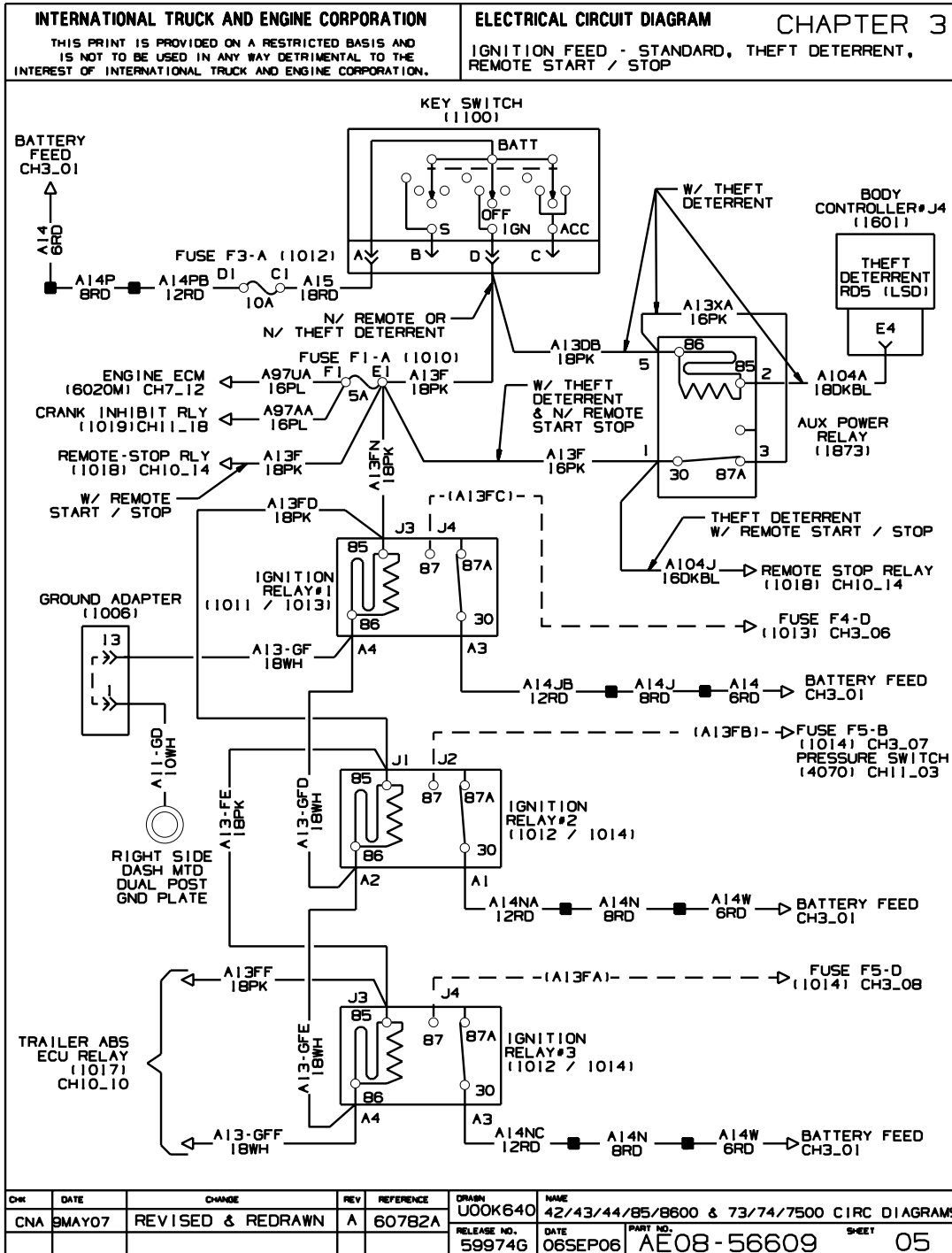

Figure 17 Ignition Feed — Standard, Theft Deterrent, Remote Start/Stop

3.6. IGNITION FEED RELAY 1, P. 6

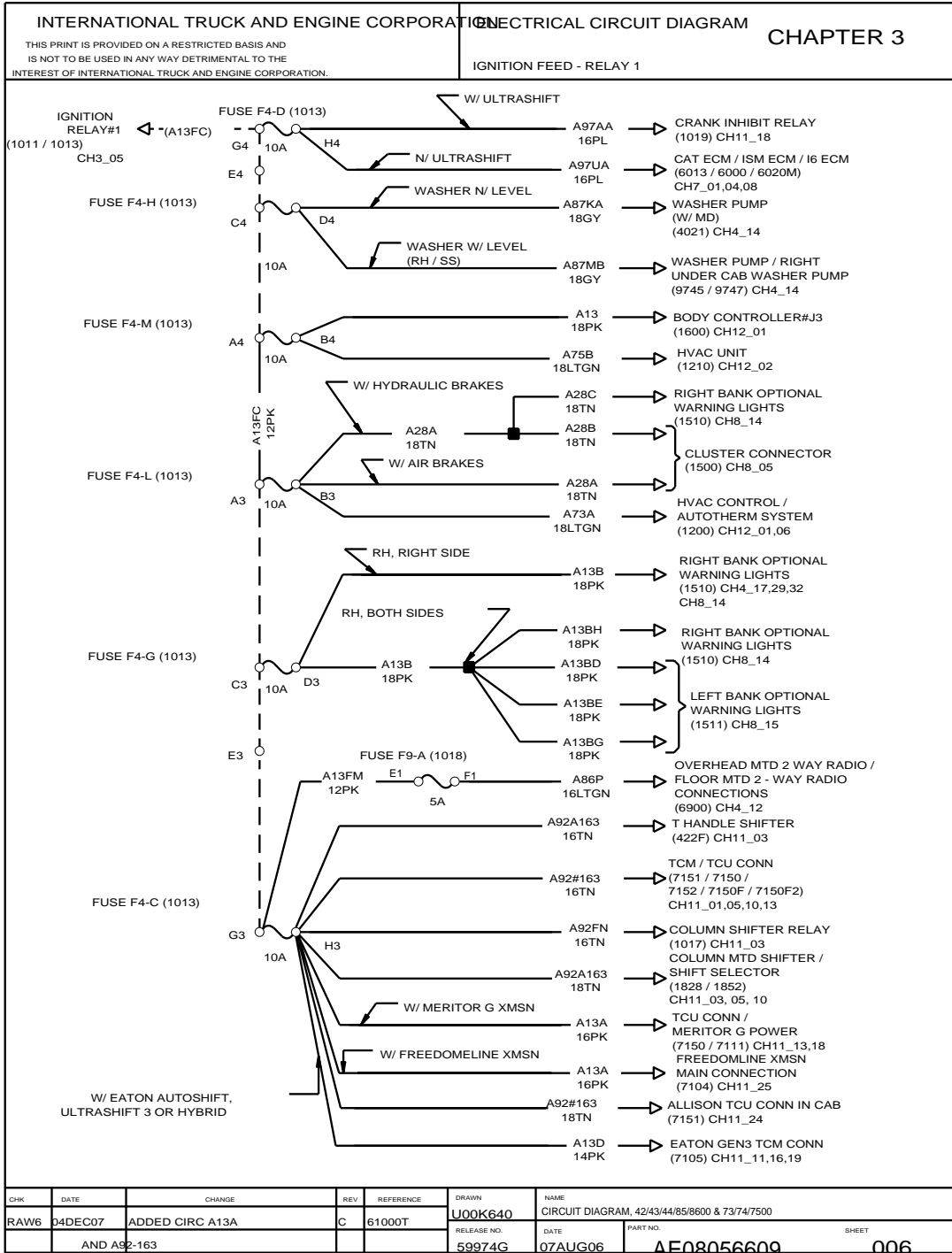

Figure 18 Ignition Feed Relay 1

3.7. IGNITION FEED RELAY 2, P. 7

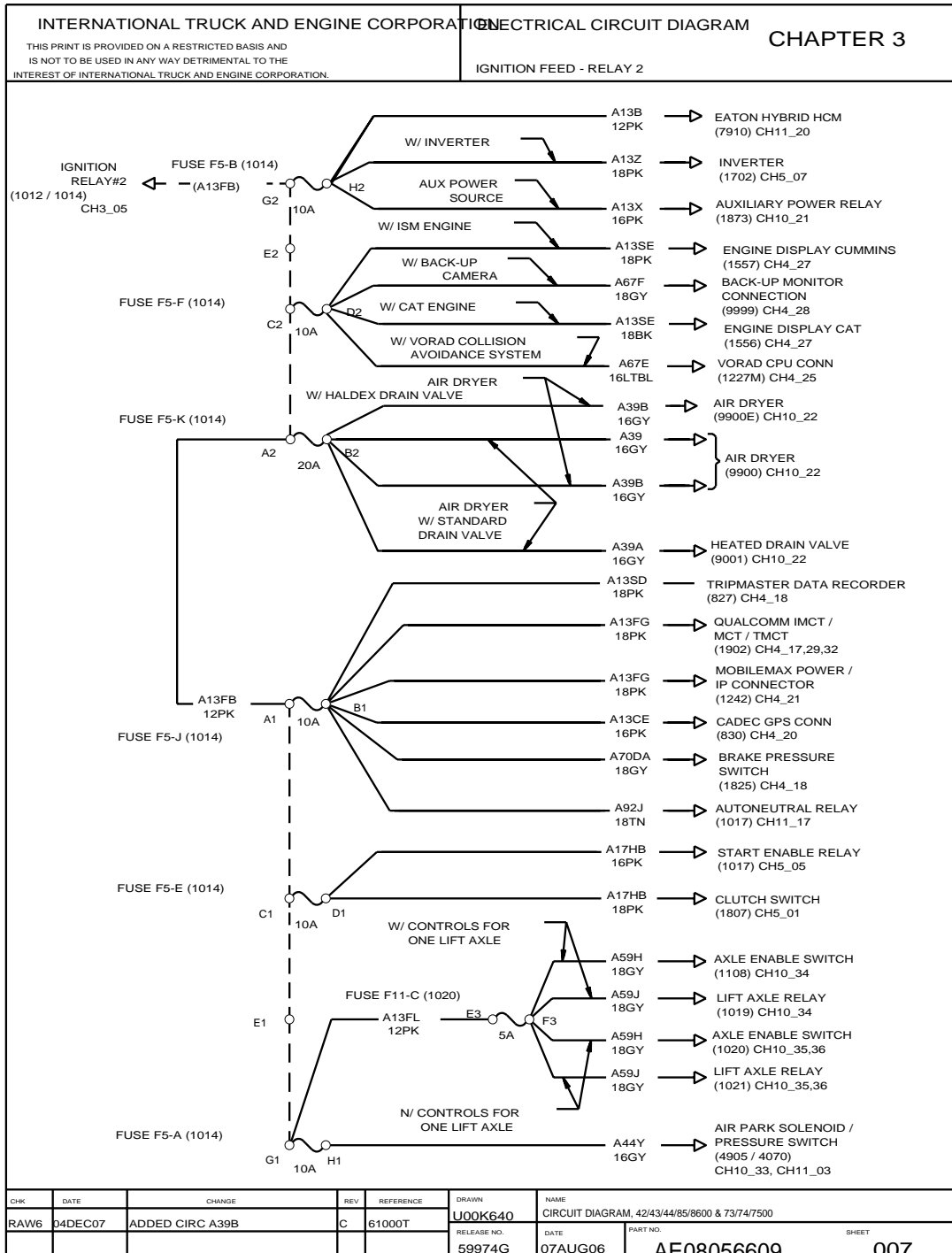

Figure 19 Ignition Feed Relay 2

3.8. IGNITION FEED RELAY 3, P. 8

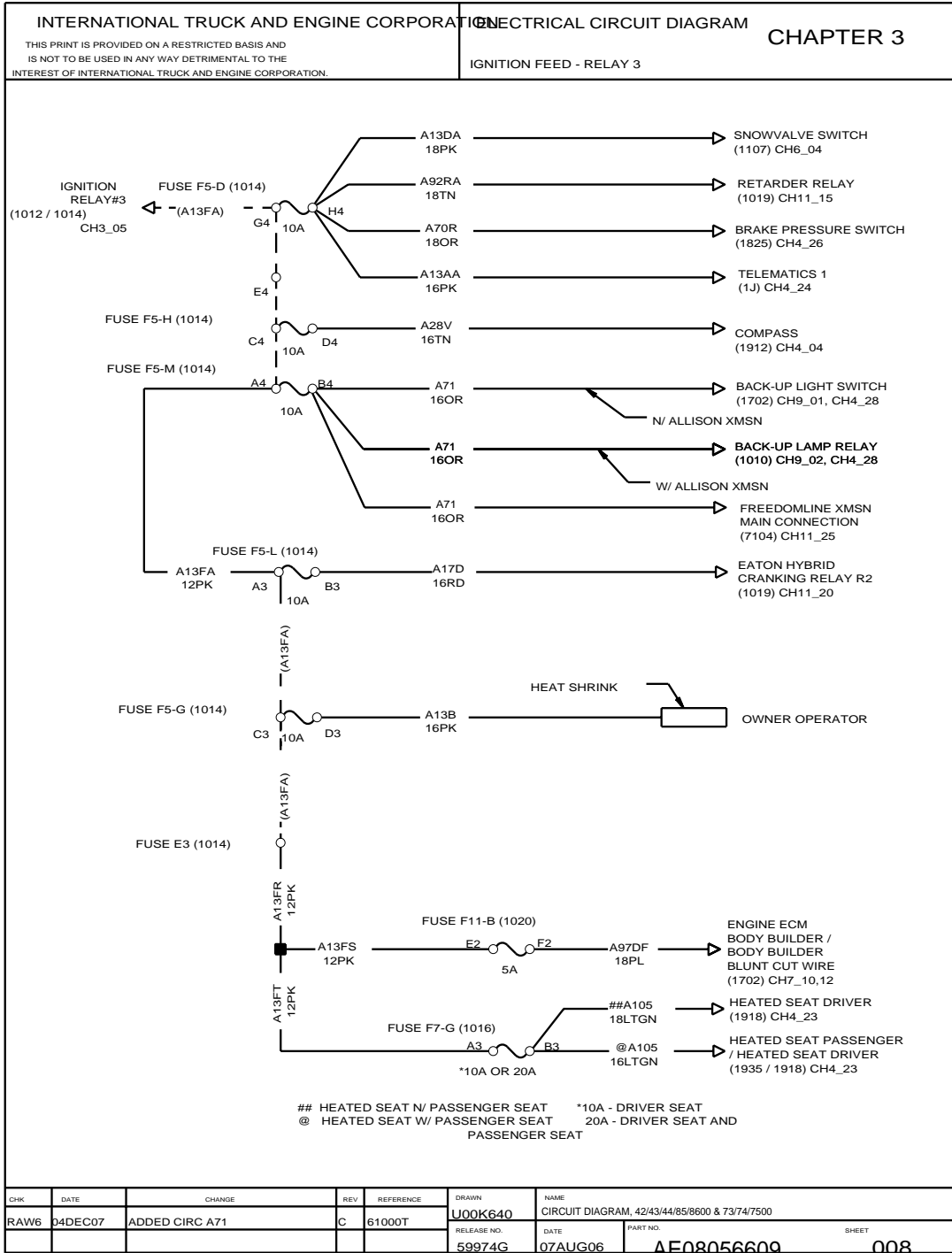

Figure 20 Ignition Feed Relay 3

3.9. J1708 DATA LINK — PUBLIC EFFECTS, P. 9

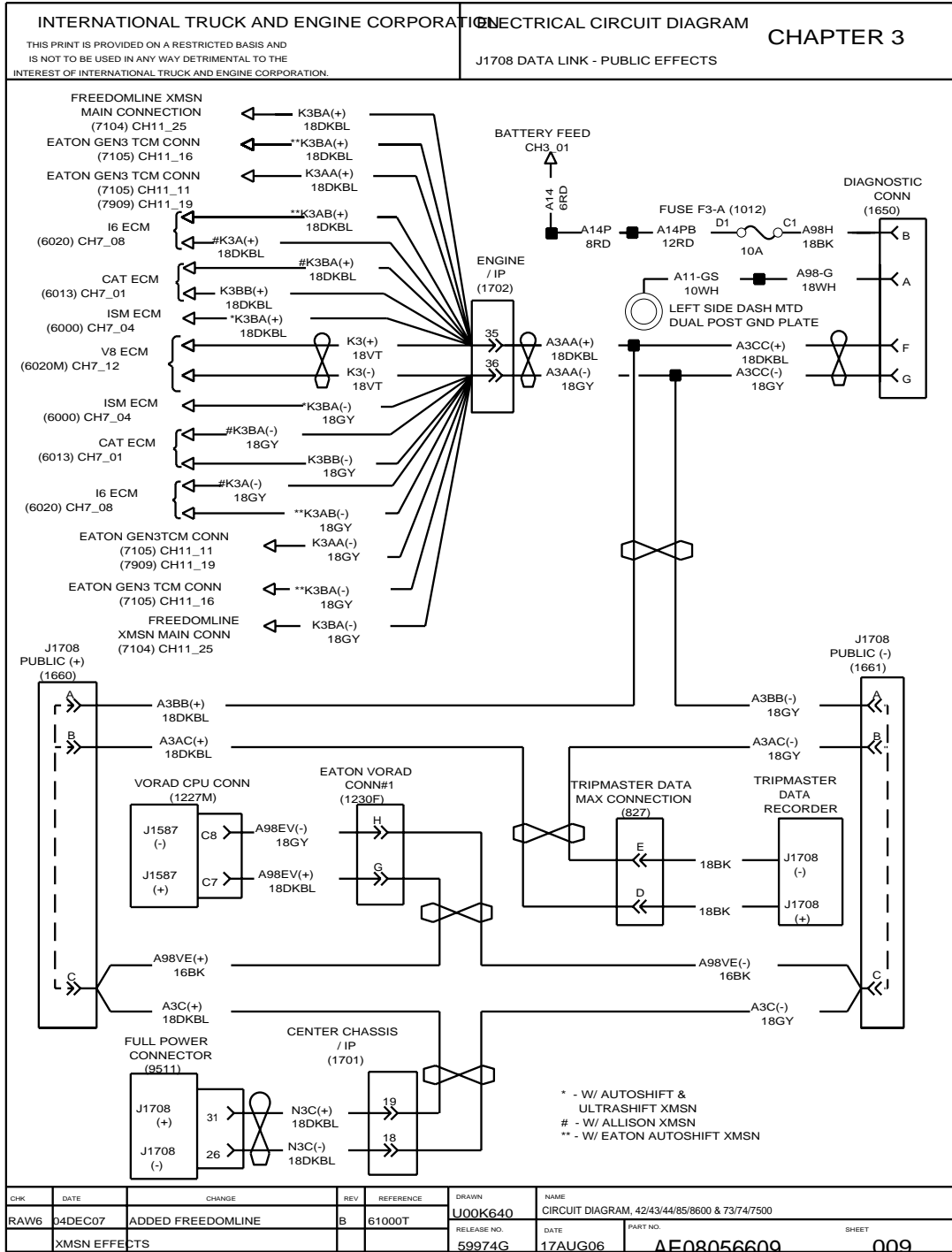

Figure 21 J1708 Data Link — Public Effects

3.10. J1708 DATA LINK — PUBLIC EFFECTS, P. 10

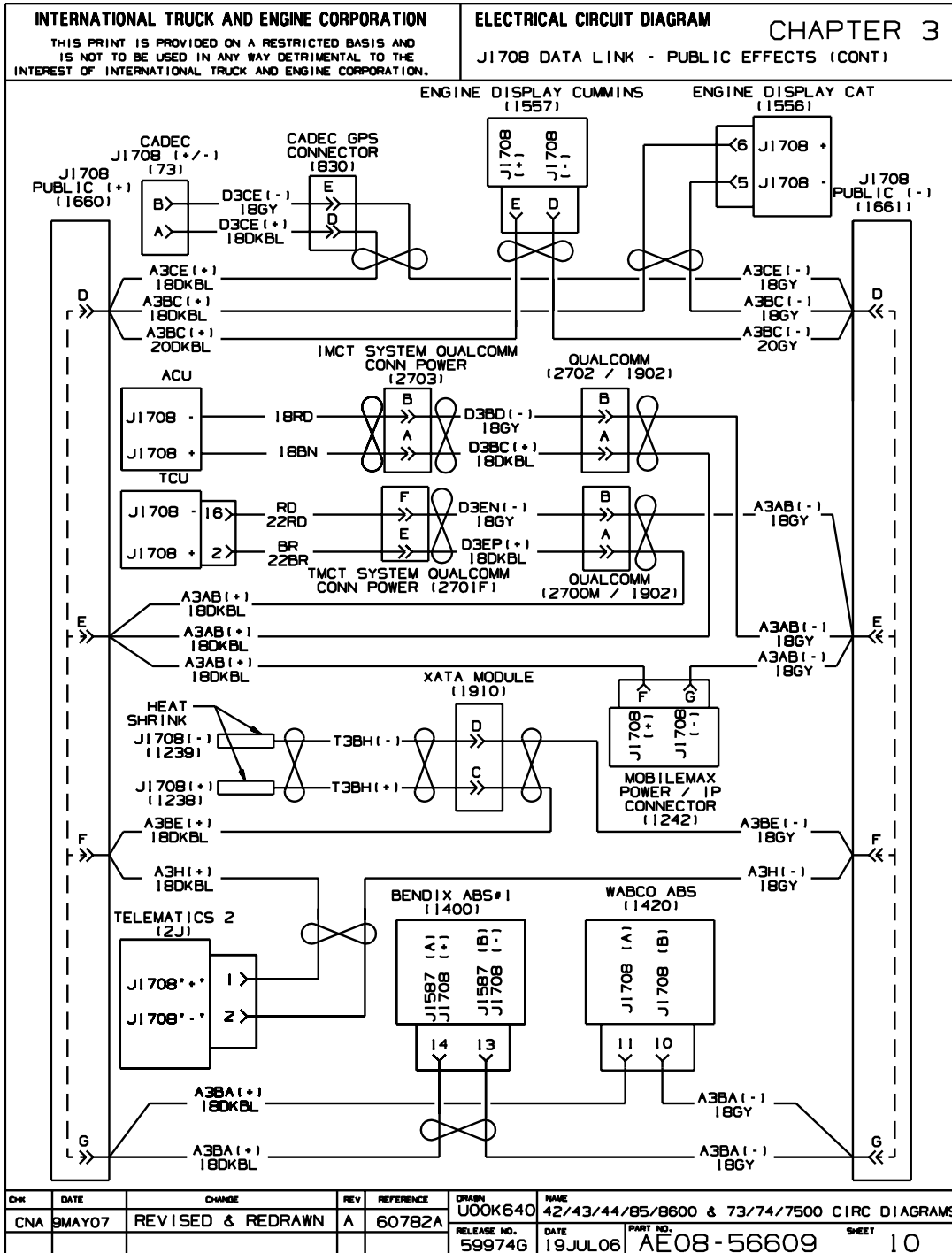

Figure 22 J1708 Data Link — Public Effects (Cont.)

3.11. J1708 DATA LINK — PRIVATE WITH POWER WINDOW AND LOCK, P. 11

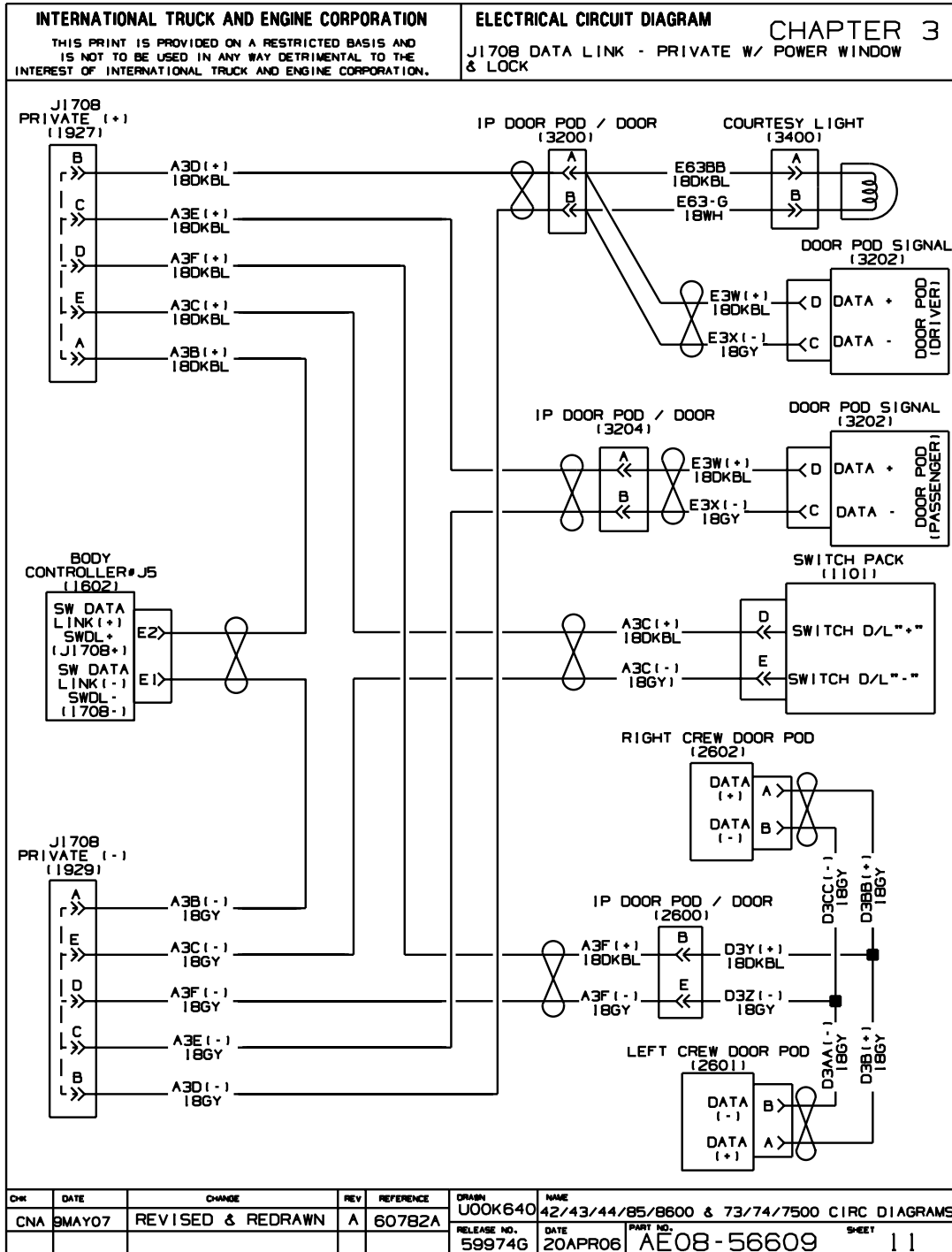

Figure 23 J1708 Data Link — Private with Power Window and Lock

3.12. J1939 DATA LINK, P. 12

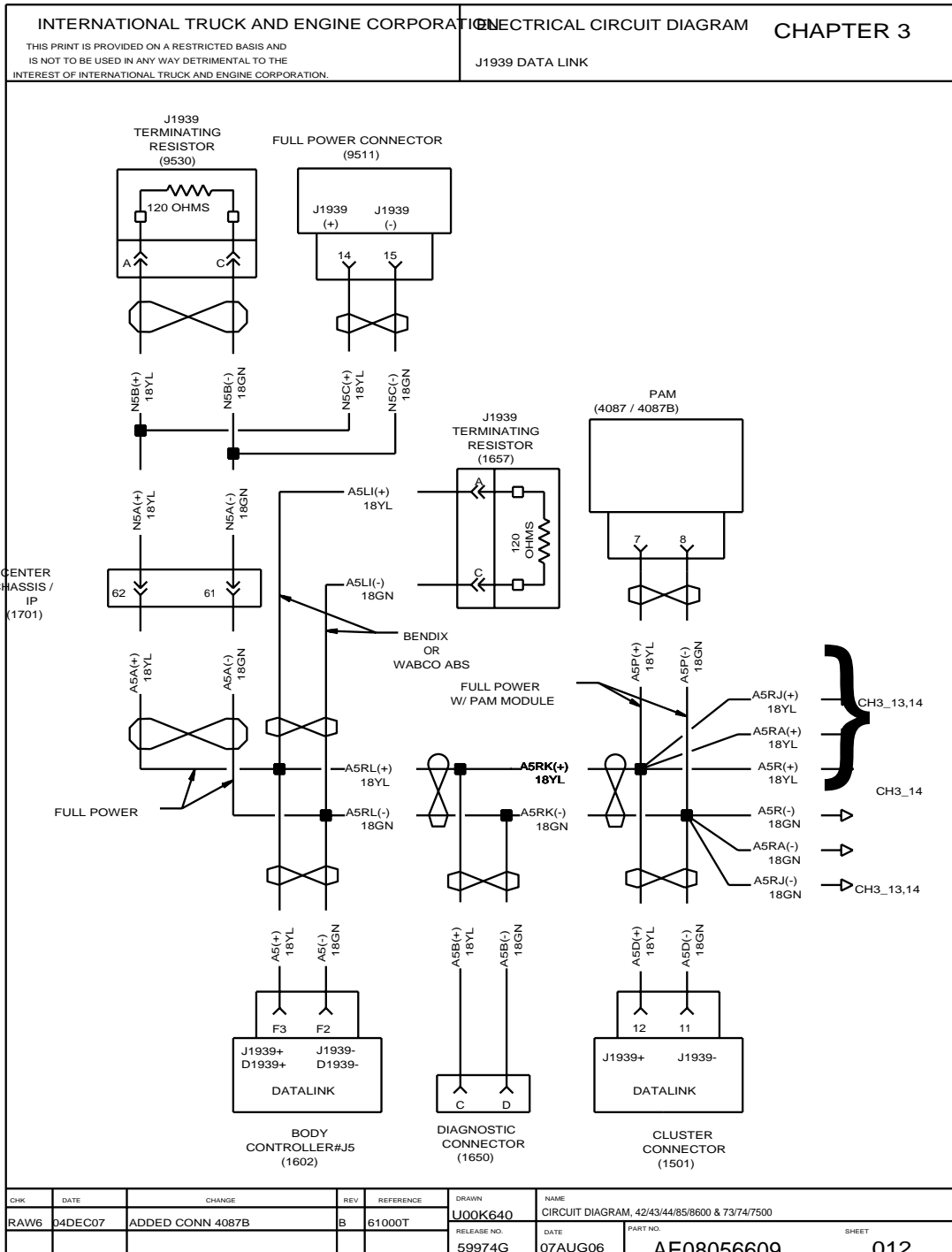

Figure 24 J1939 Data Link

3.13. J1939 DATA LINK WITH OPTIONS, P. 13

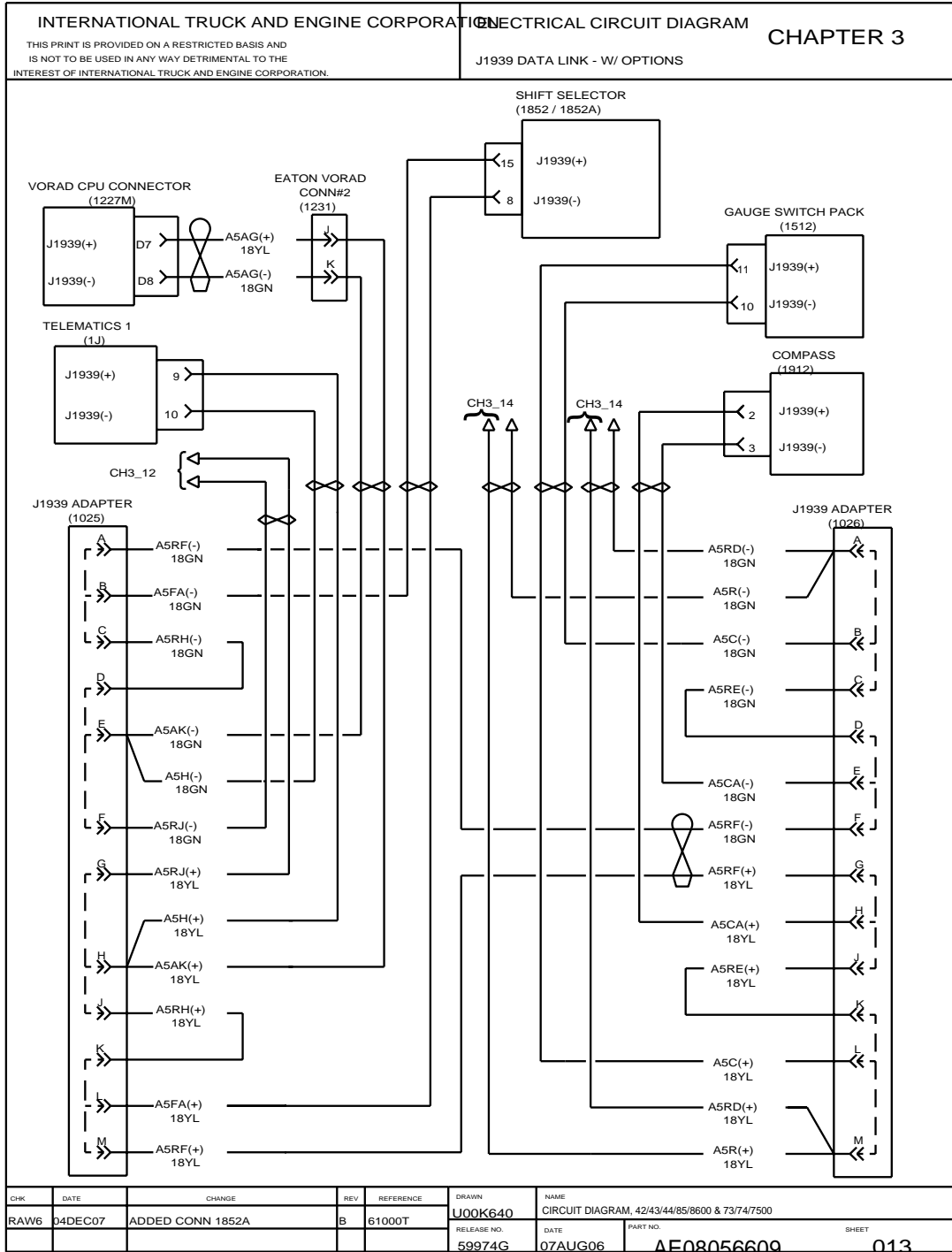

Figure 25 J1939 Data Link with Options

3.14. J1939 DATA LINK WITH OPTIONS, P. 14

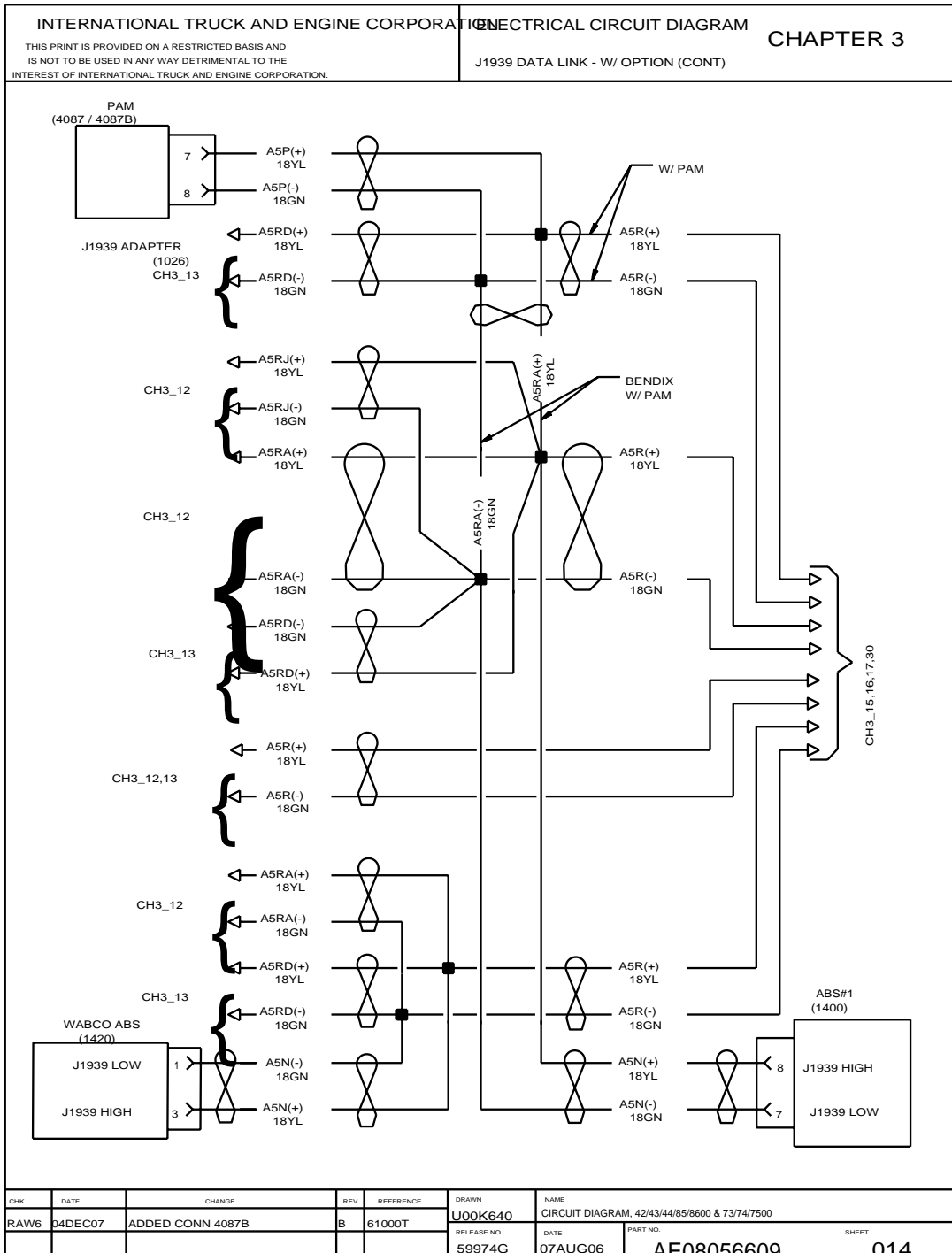

Figure 26 J1939 Data Link with Options

3.15. J1939 DATA LINK — ISM 2007 ENGINE, P. 15

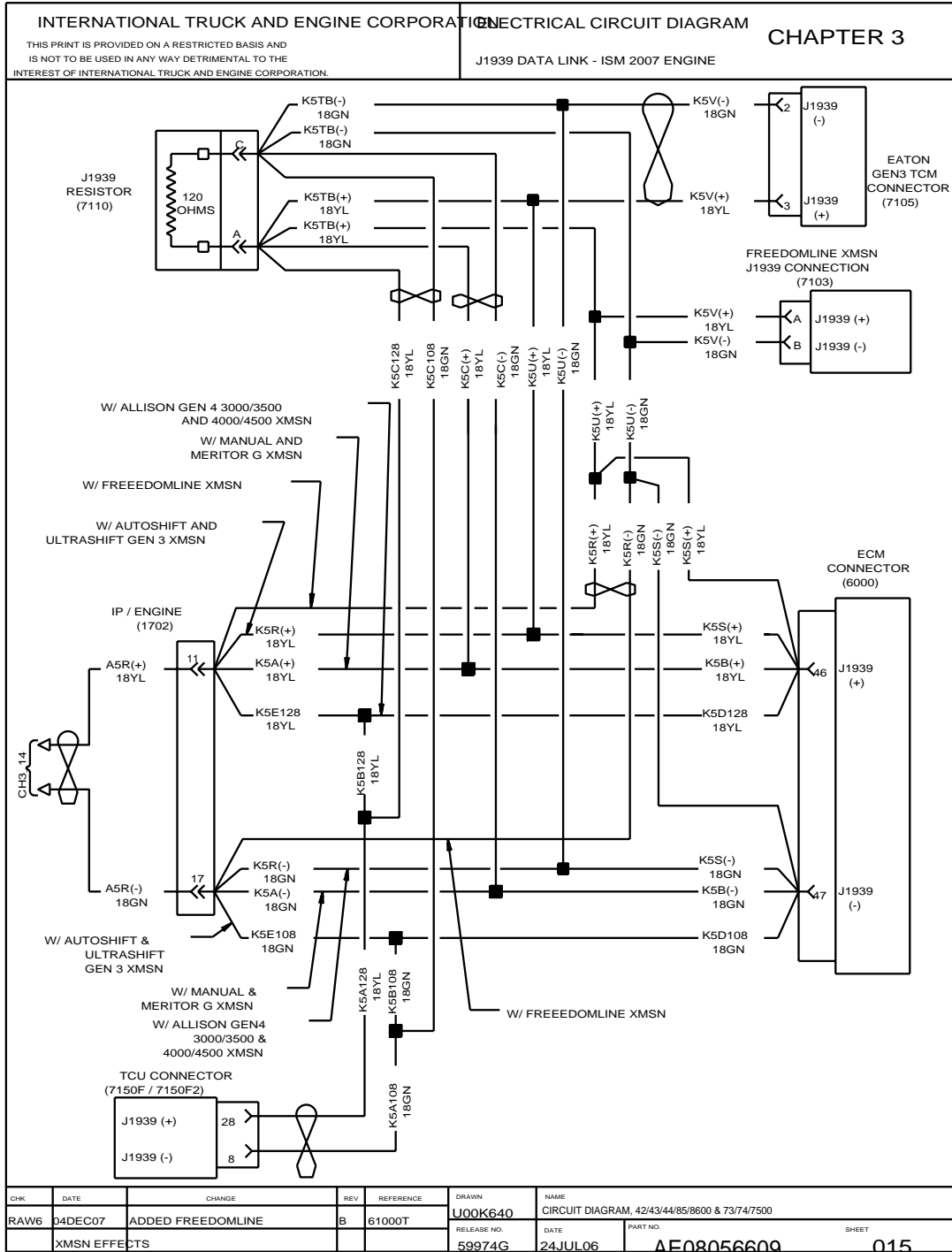

Figure 27 J1939 Data Link — ISM 2007 Engine

3.16. J1939 DATA LINK — I6 2007 ENGINE, P. 16

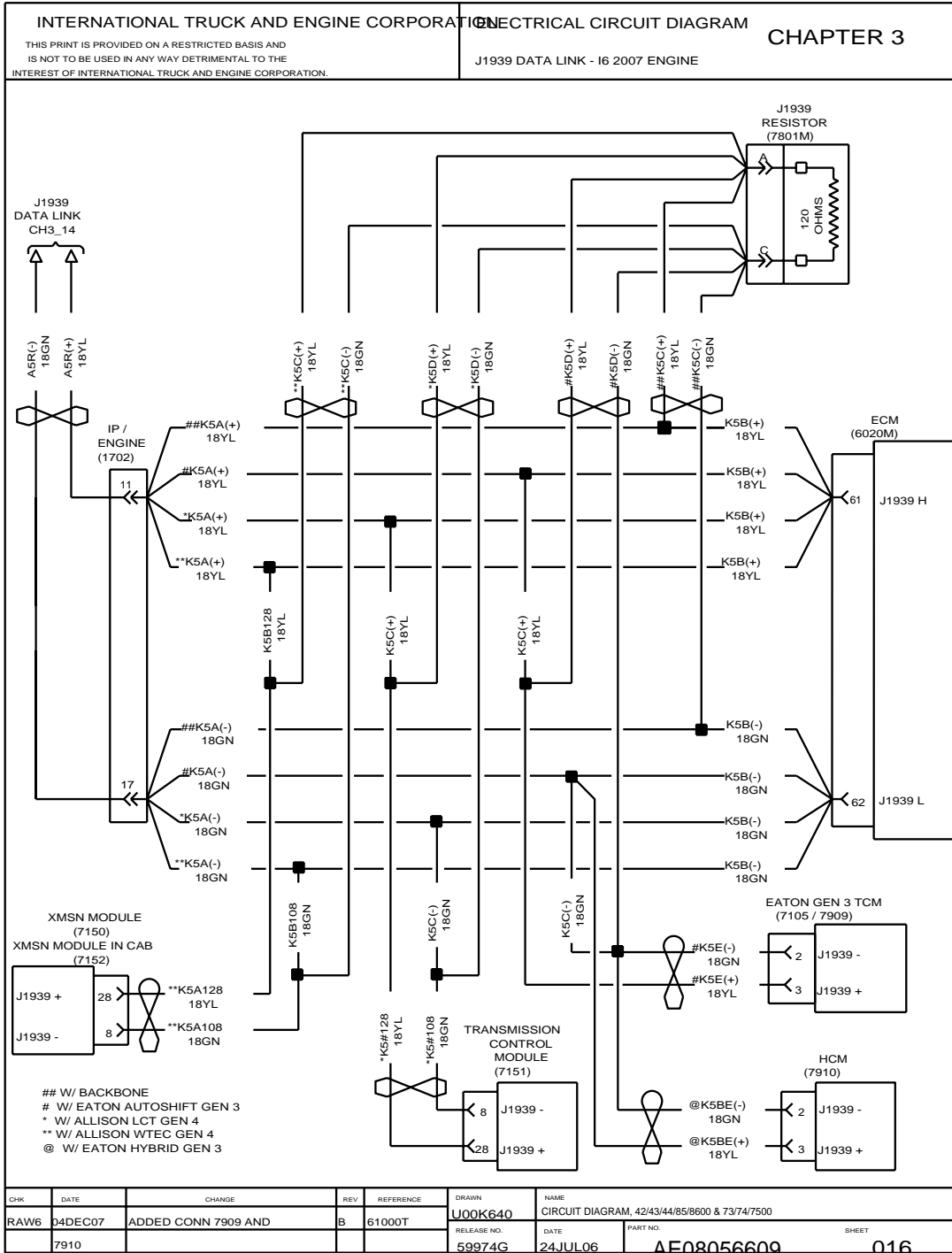

Figure 28 J1939 Data Link — I6 2007 Engine

3.17. J1939 DATA LINK — C11/C13 2007 ENGINE, P. 17

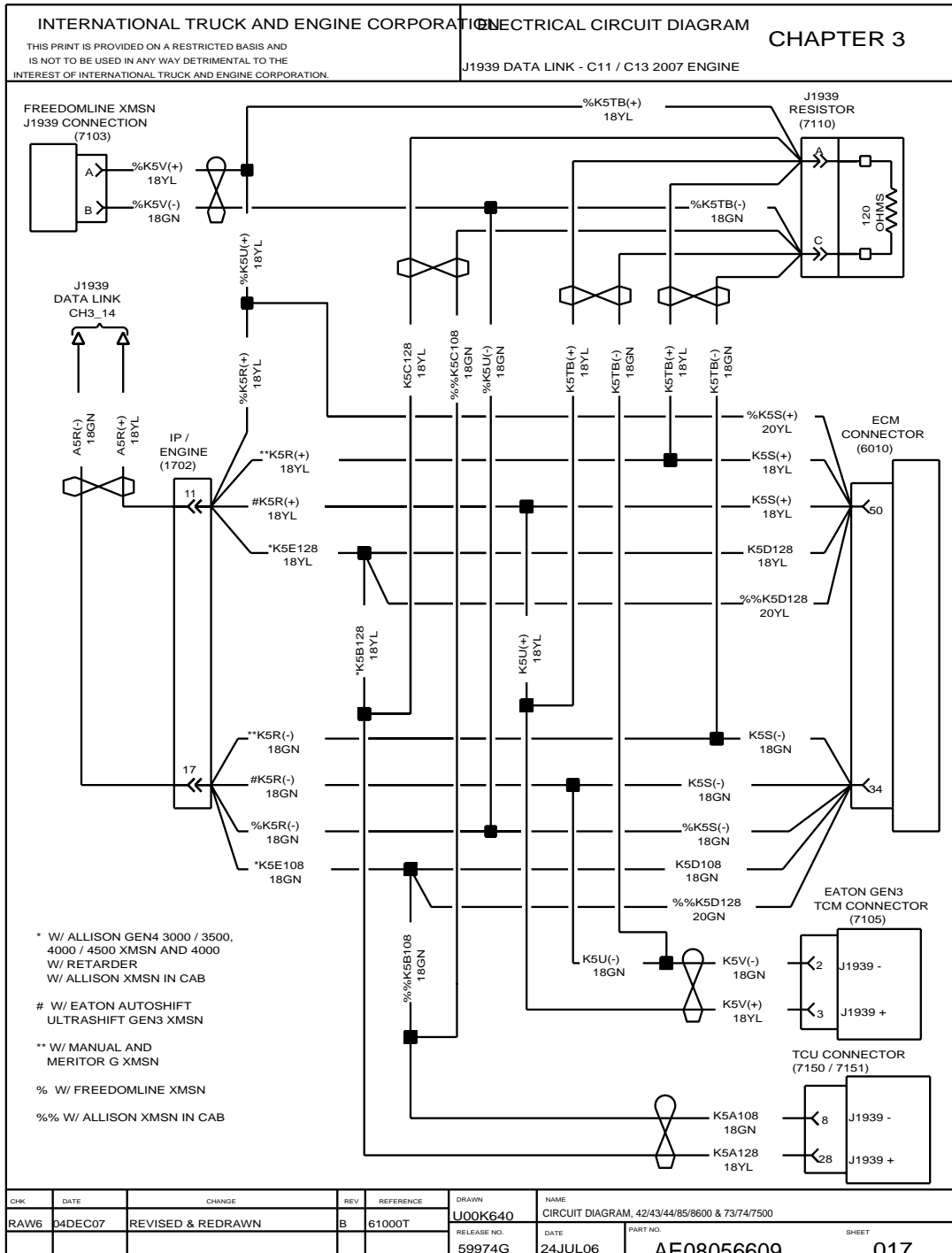

Figure 29 J1939 Data Link — C11/C13 2007 Engine

3.18. GROUND — IP, P. 18

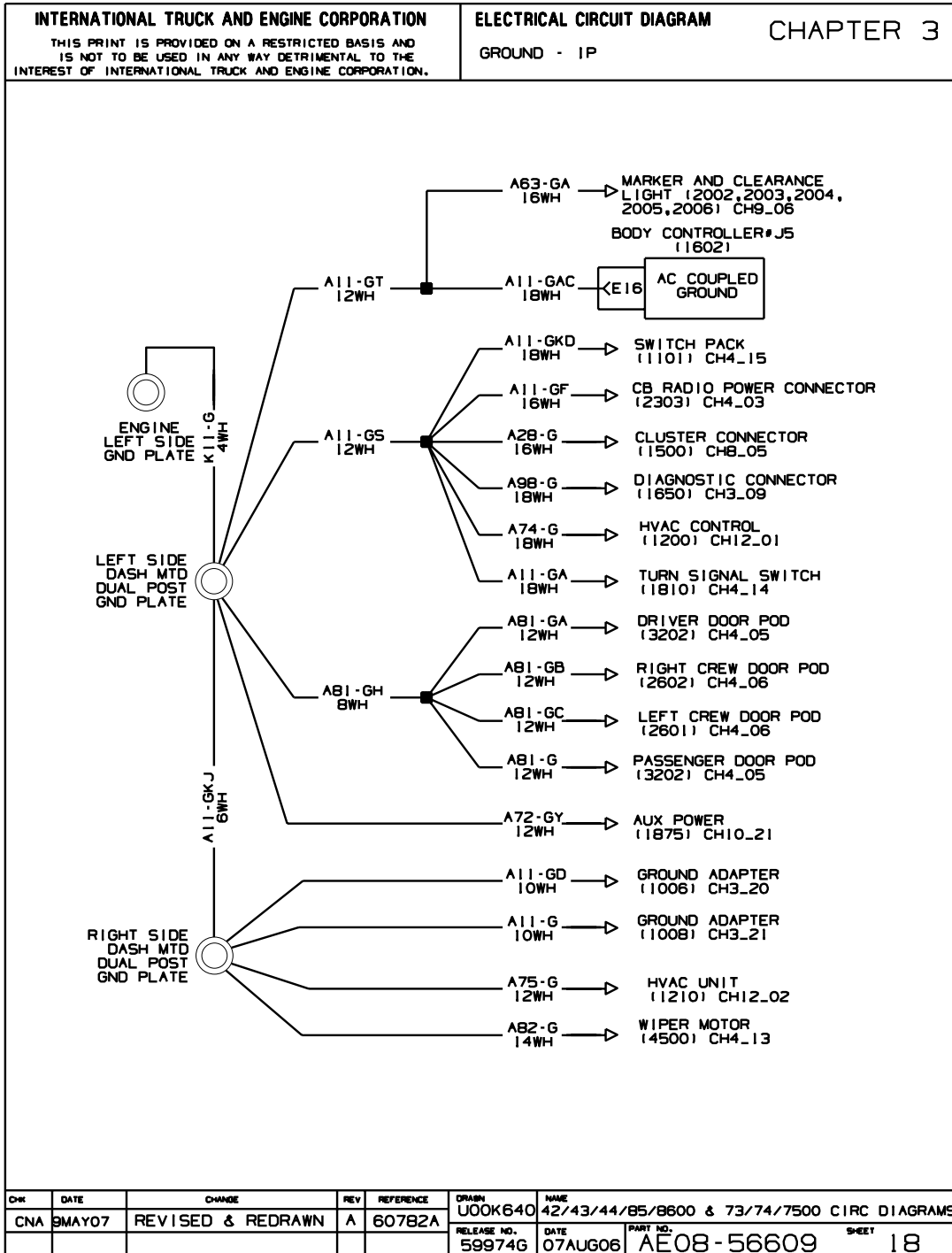

Figure 30 Ground — IP

3.19. GROUND — IP, P. 19

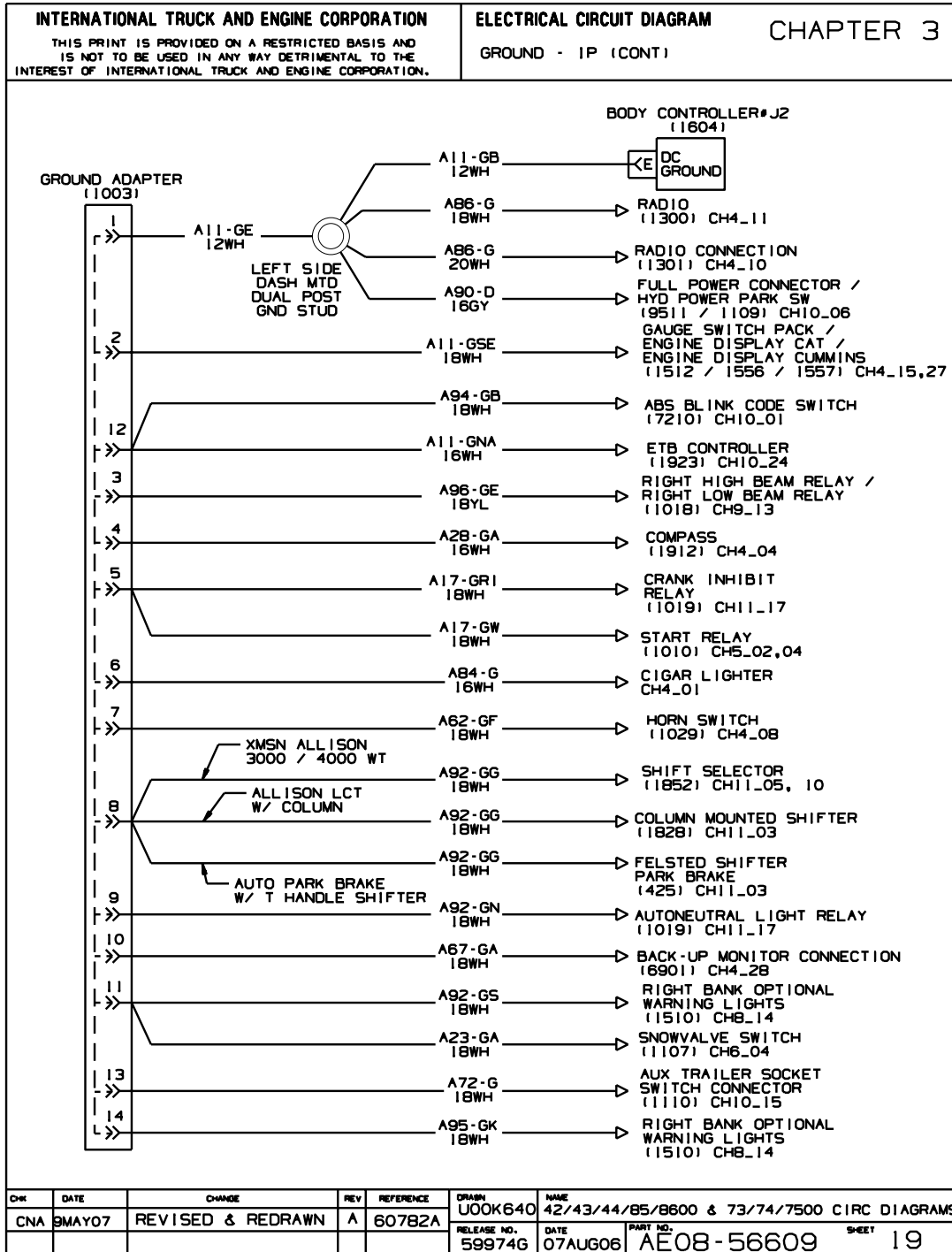

Figure 31 Ground — IP (Cont.)

3.20. GROUND — IP, P. 20

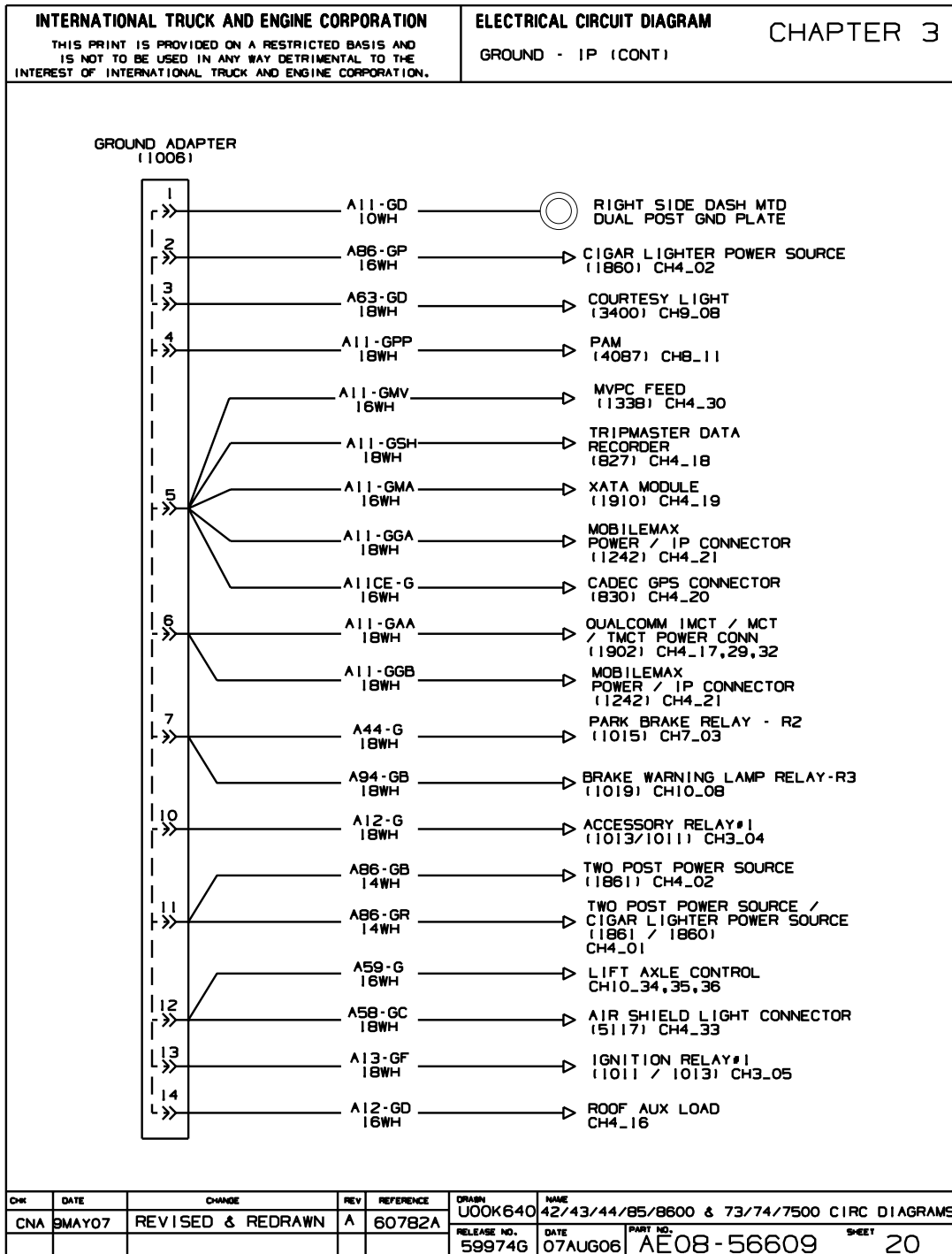

Figure 32 Ground — IP (Cont.)

3.21. GROUND — IP, P. 21

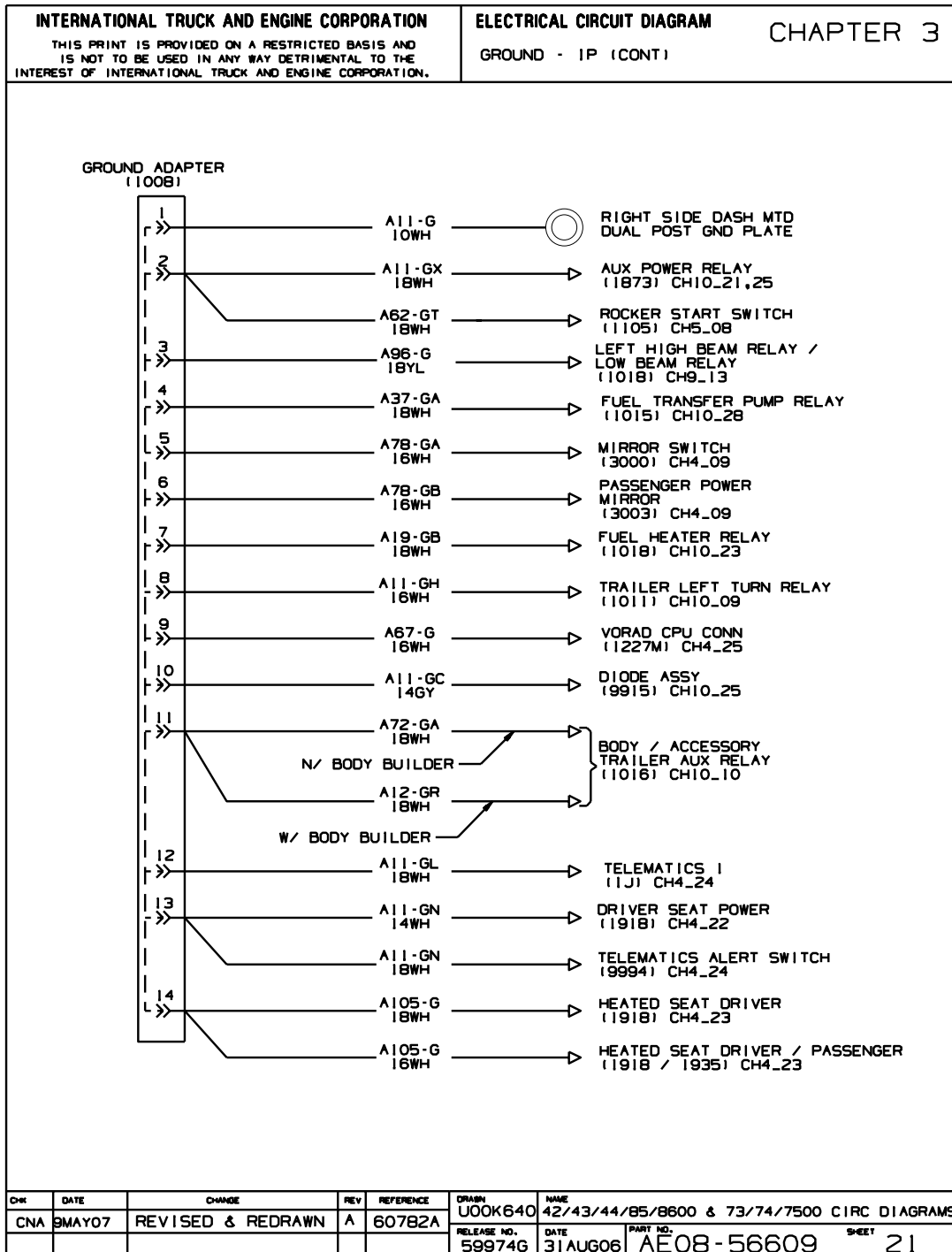

Figure 33 Ground — IP (Cont.)

3.22. ENGINE GROUND, P. 22

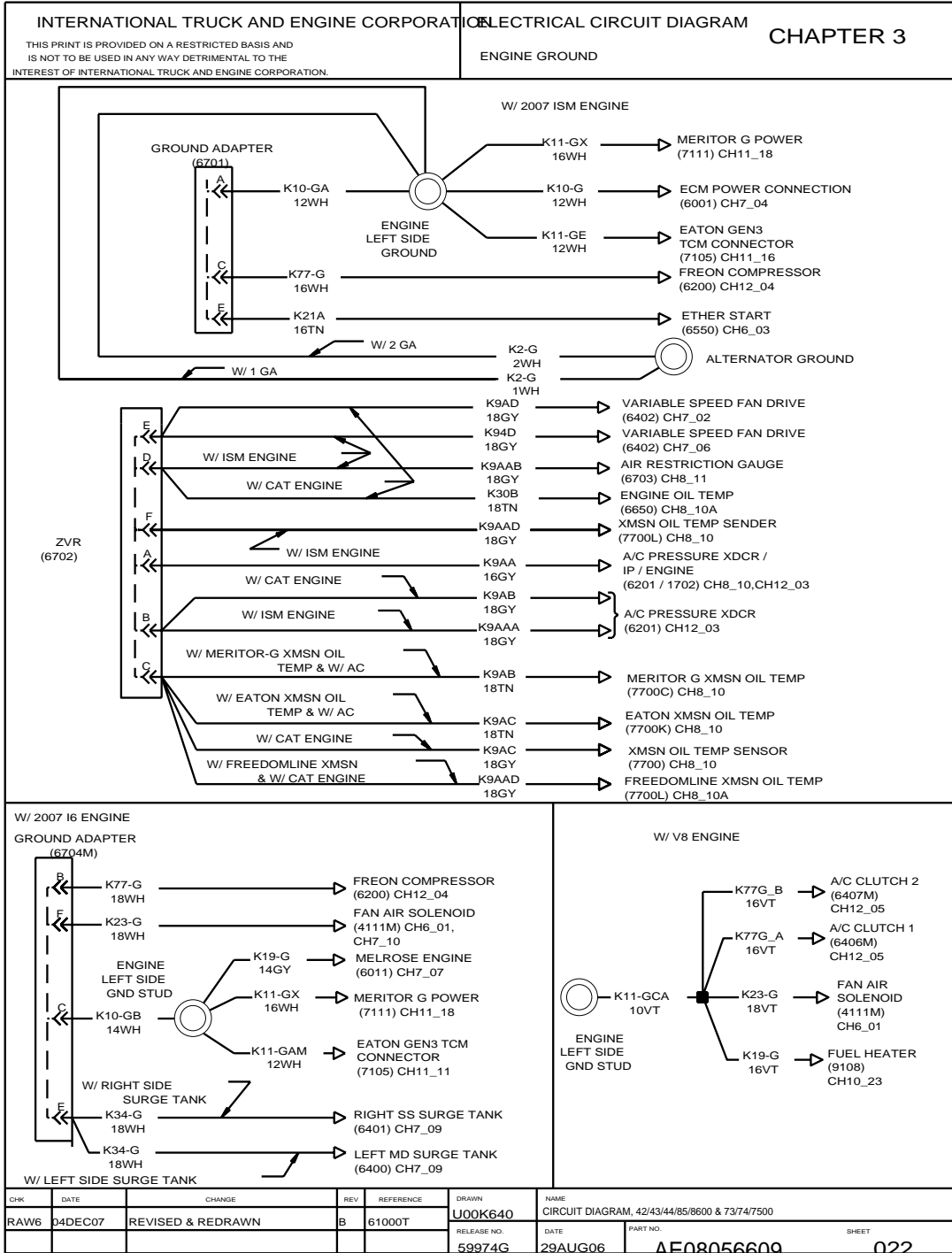

Figure 34 Engine Ground

3.23. ENGINE GROUND, P. 23

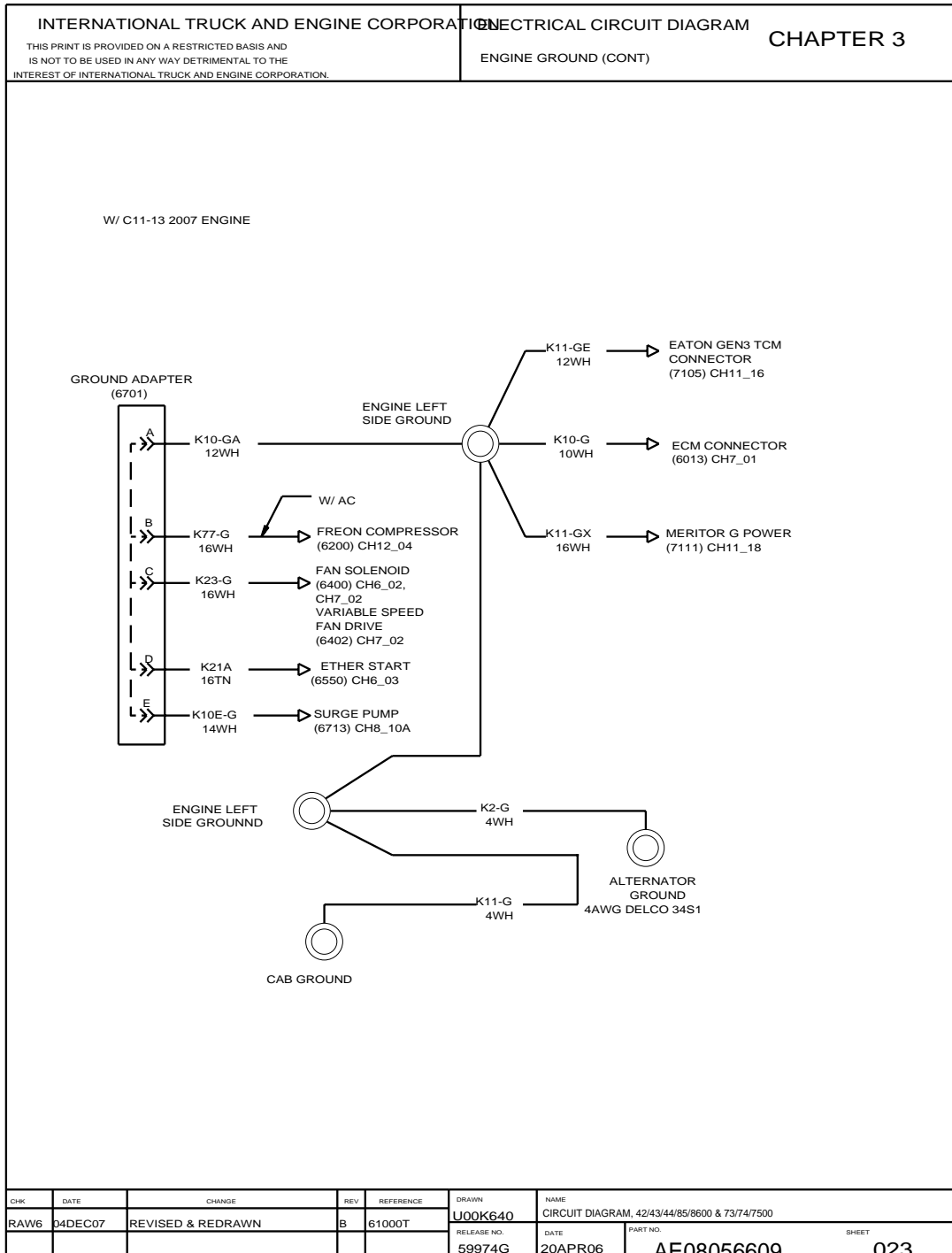

Figure 35 Engine Ground (Cont.)

3.24. GROUND — CHASSIS, P. 24

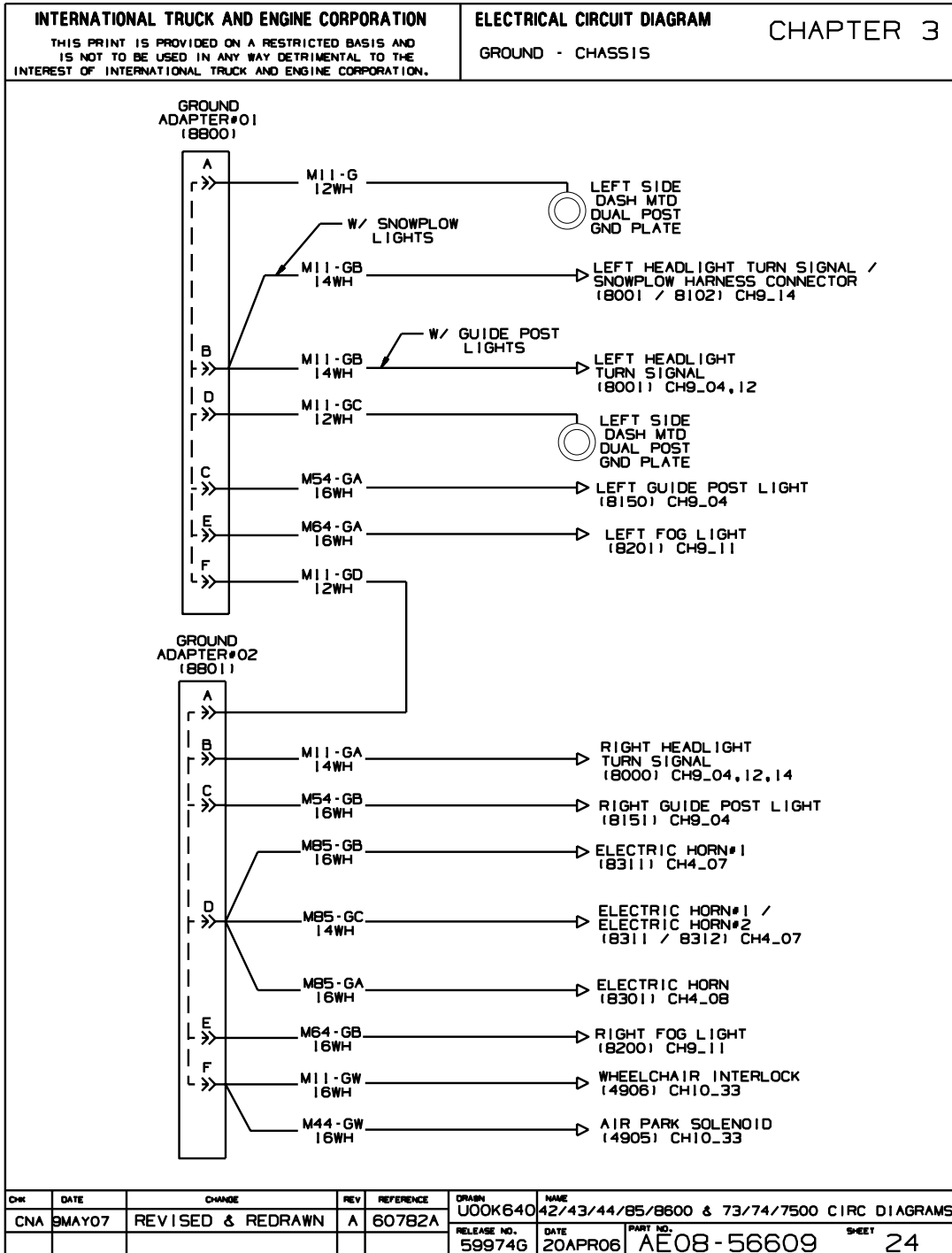

Figure 36 Ground — Chassis

3.25. GROUND — CHASSIS WITH HEAVY DUTY DIESEL, P. 25

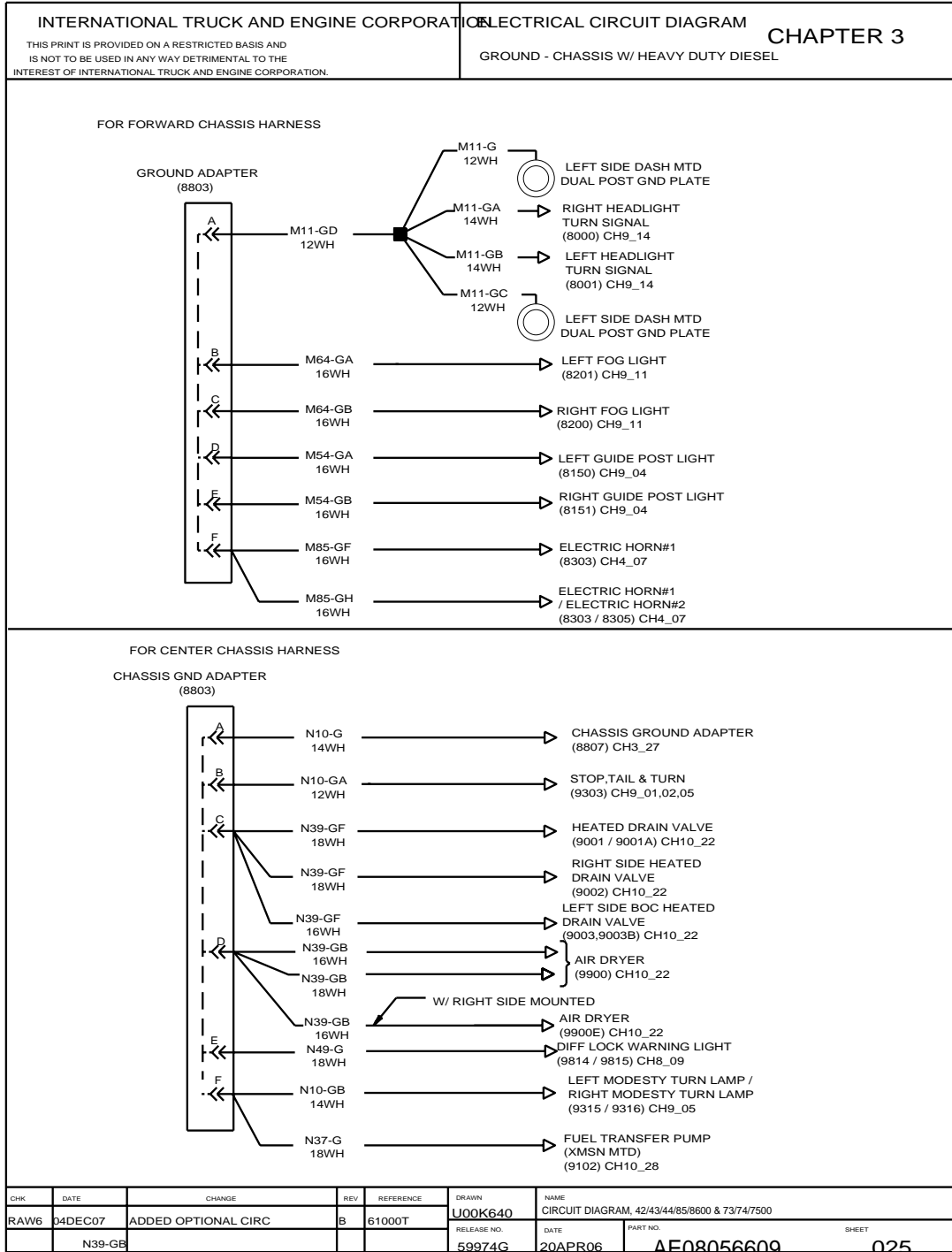

Figure 37 Ground — Chassis with Heavy Duty Diesel

3.26. GROUND — CHASSIS, P. 26

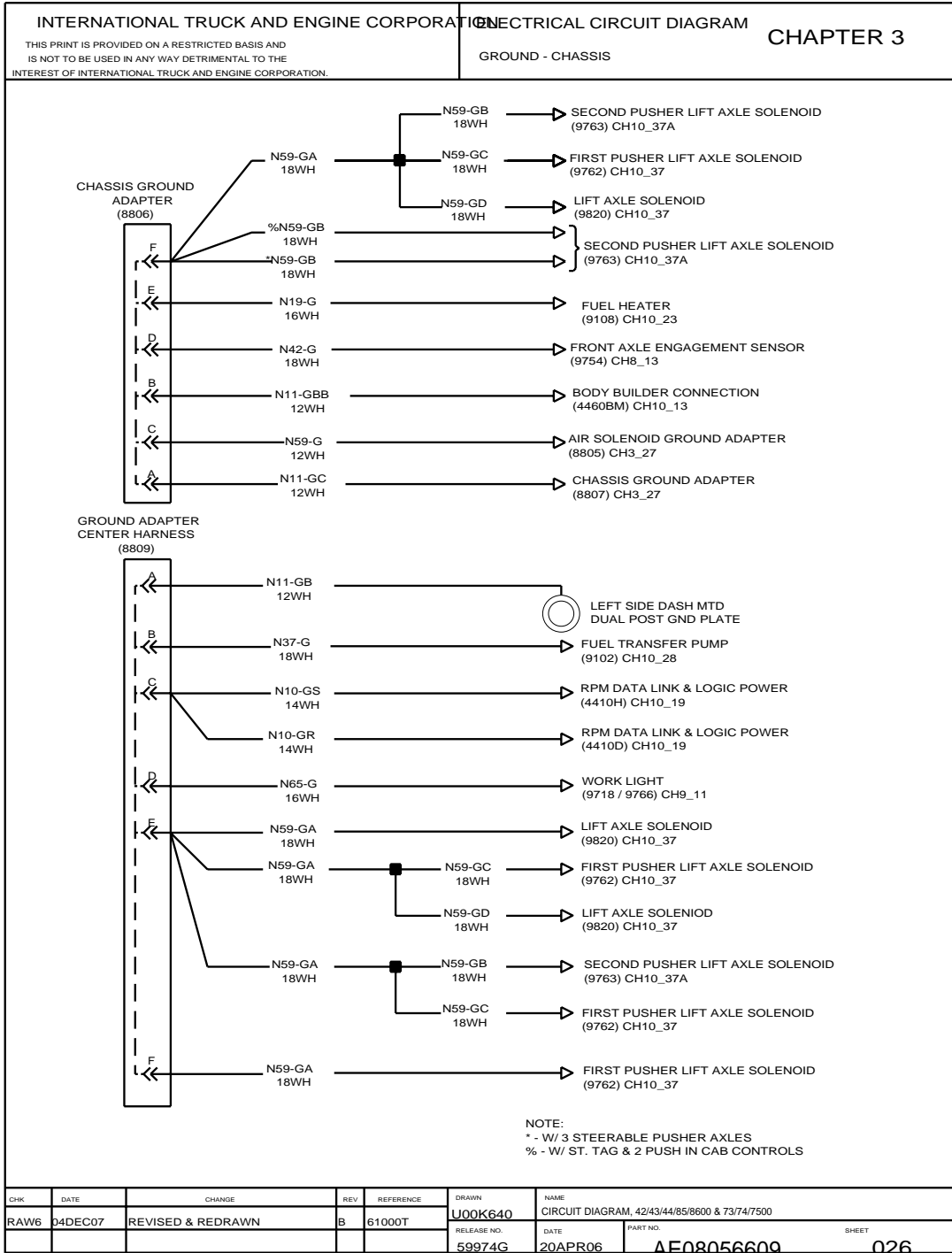

Figure 38 Ground — Chassis

3.27. ZERO VOLT REFERENCE, P. 27

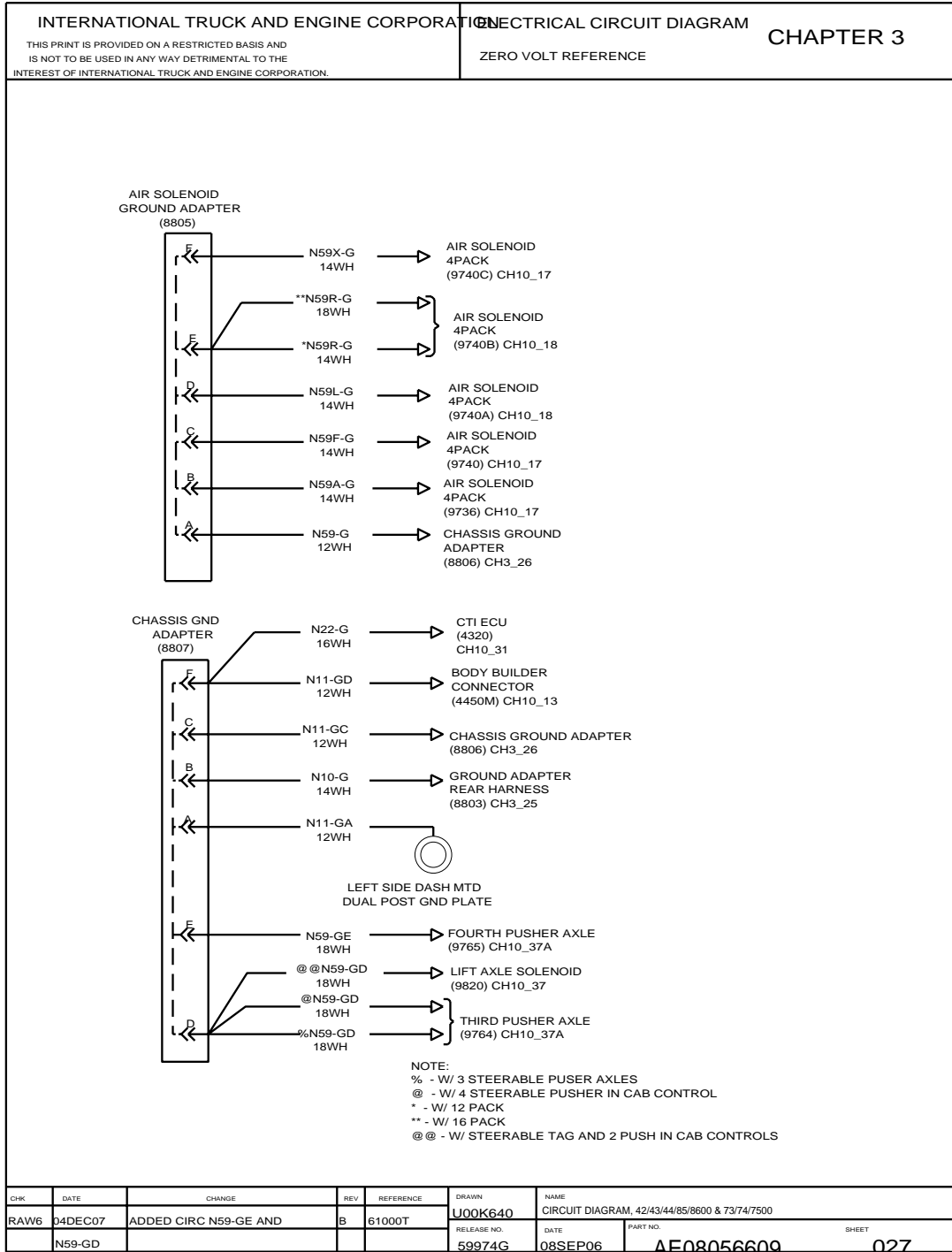

Figure 39 Zero Volt Reference

3.28. ZERO VOLT REFERENCE, P. 28

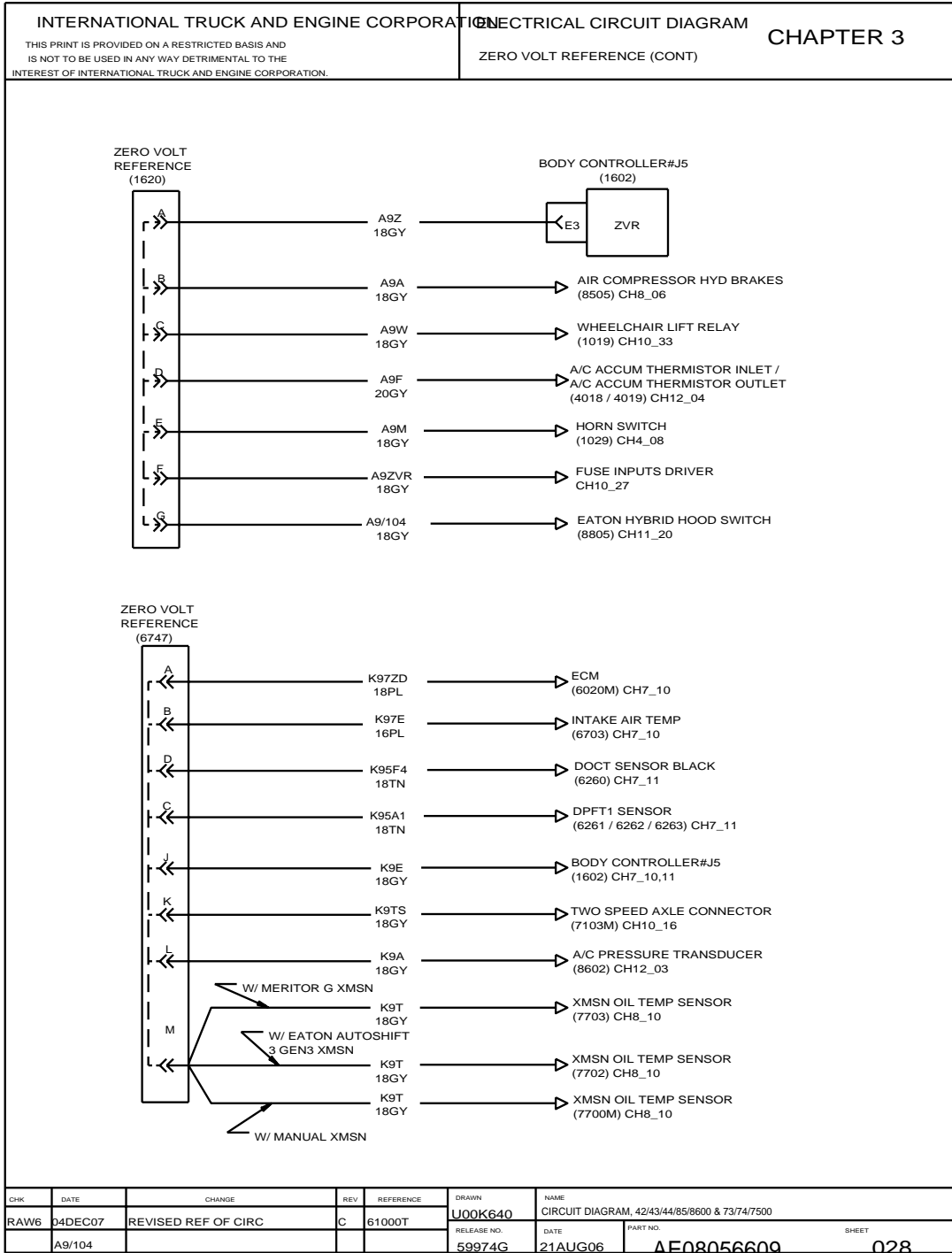

Figure 40 Zero Volt Reference

3.29. GROUND — CHASSIS, P. 29

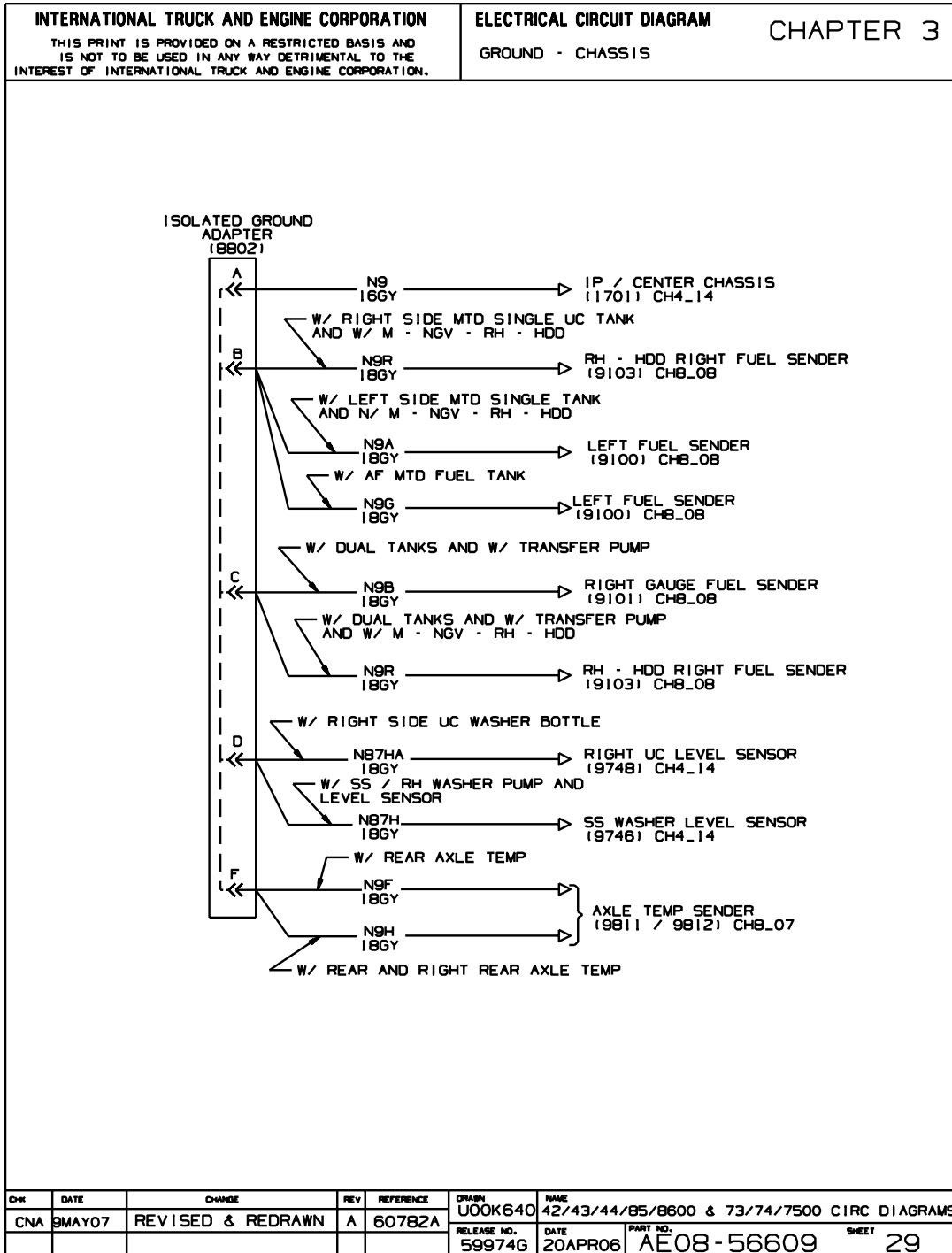

Figure 41 Ground — Chassis

3.30. J1939 DATA LINK WITH V8 ENGINE, P. 30

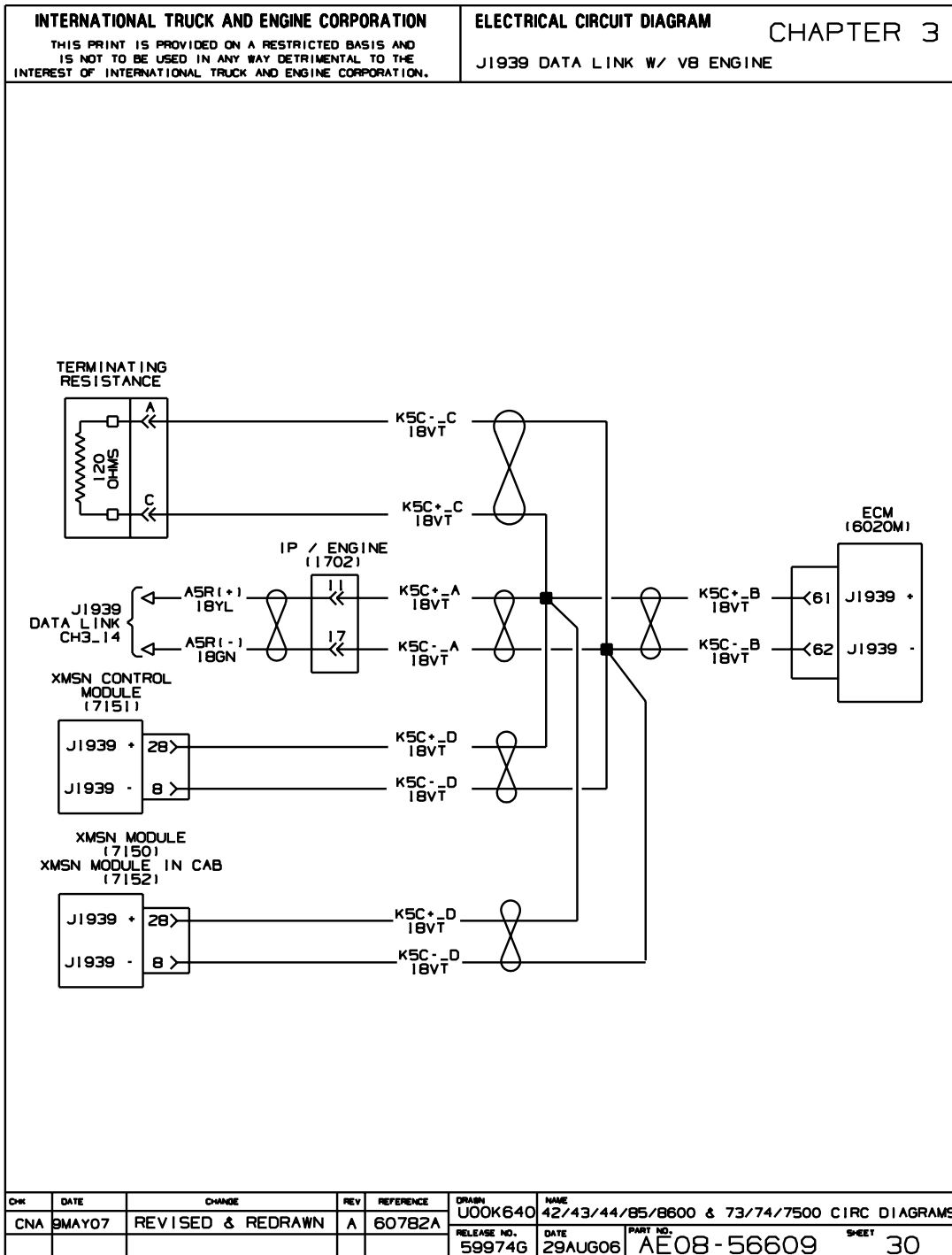

Figure 42 J1939 Data Link with V8 Engine

4. CAB ACCESSORIES (CHAPTER 4)

4.1. CIGAR LIGHTER AND POWER FEED, P. 1

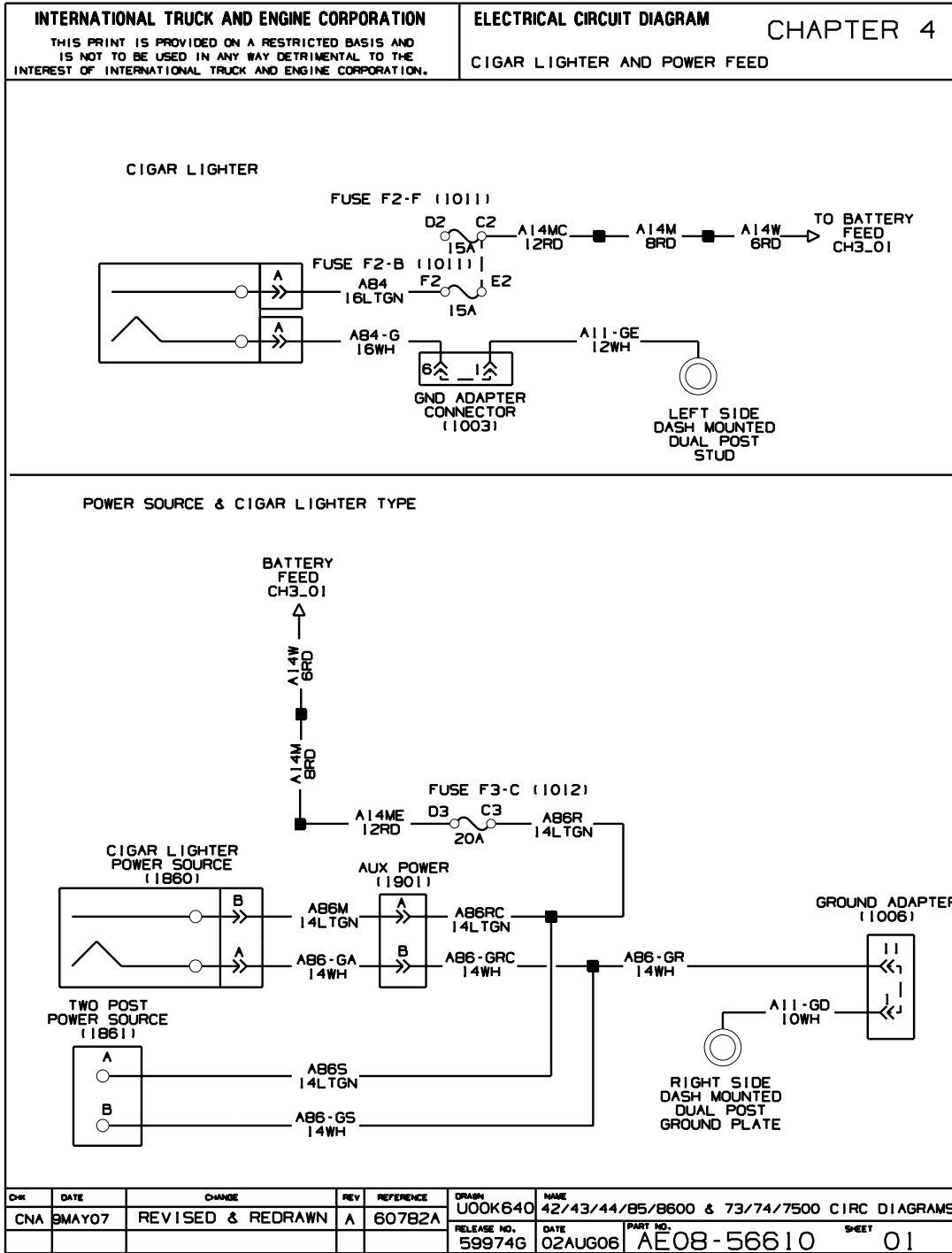

Figure 43 Cigar Lighter and Power Feed

4.2. CIGAR LIGHTER AND POWER FEED, P. 2

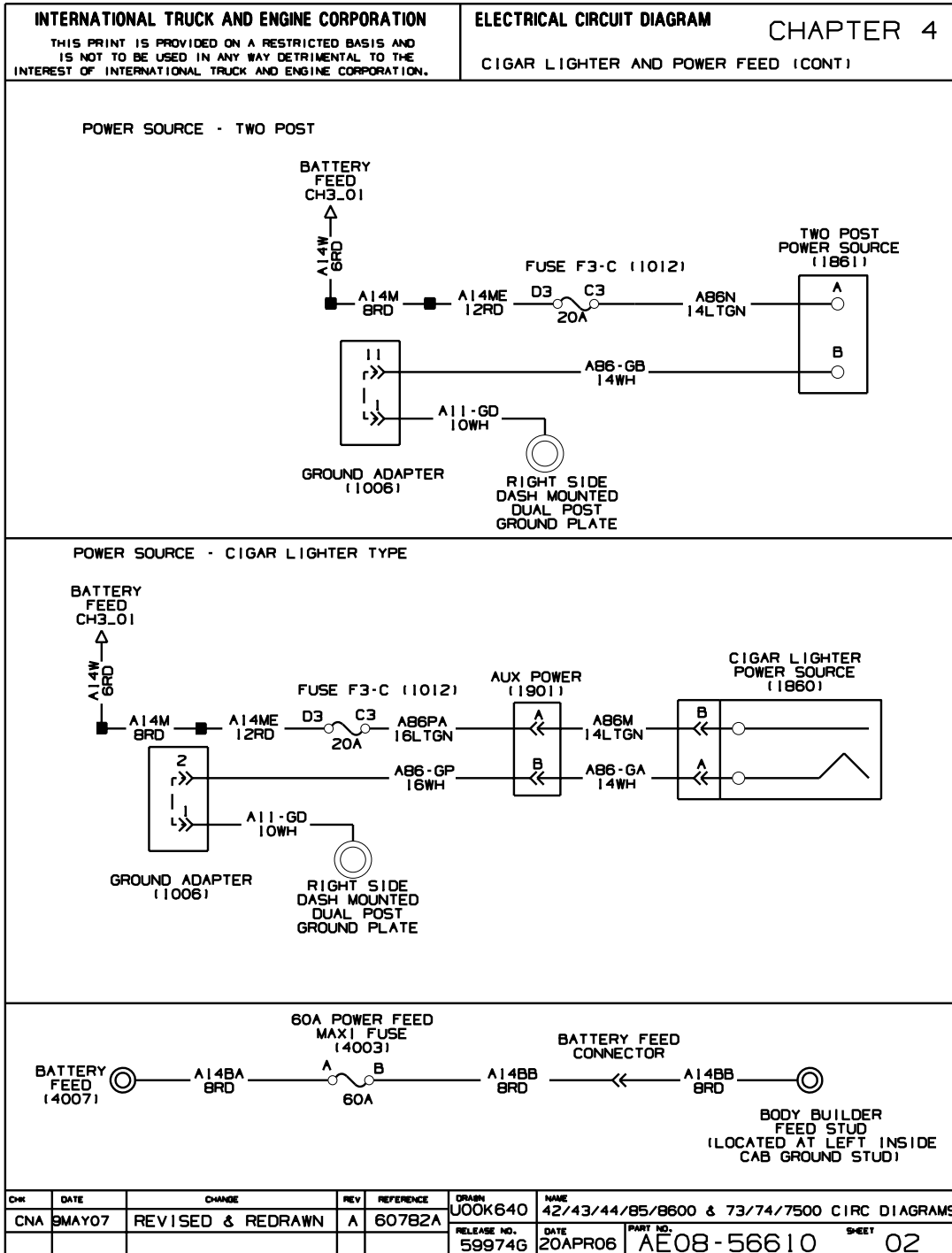

Figure 44 Cigar Lighter and Power Feed

4.3. CB POWER RADIO, P. 3

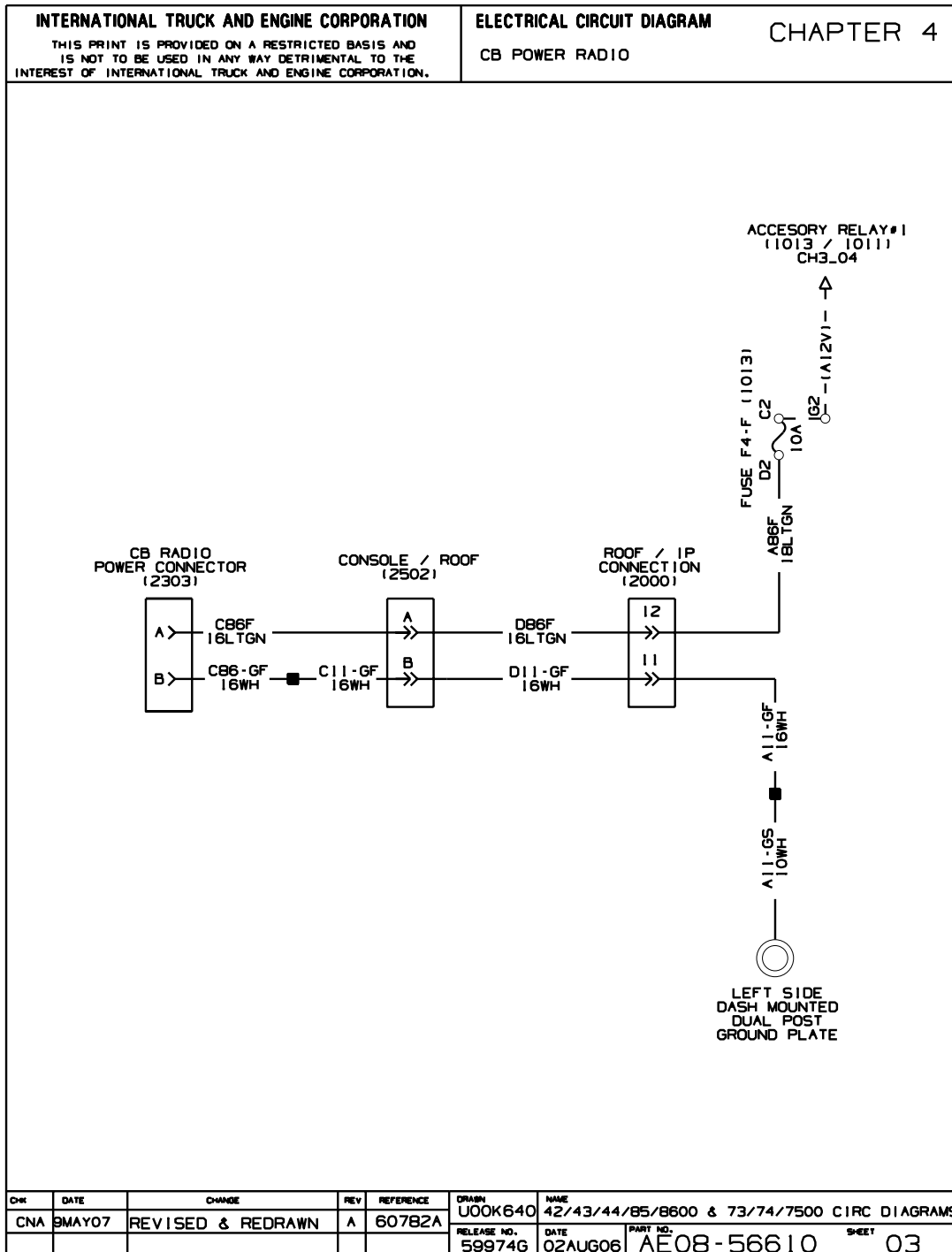

Figure 45 CB Power Radio

4.4. COMPASS AND TEMPERATURE DISPLAY, P. 4

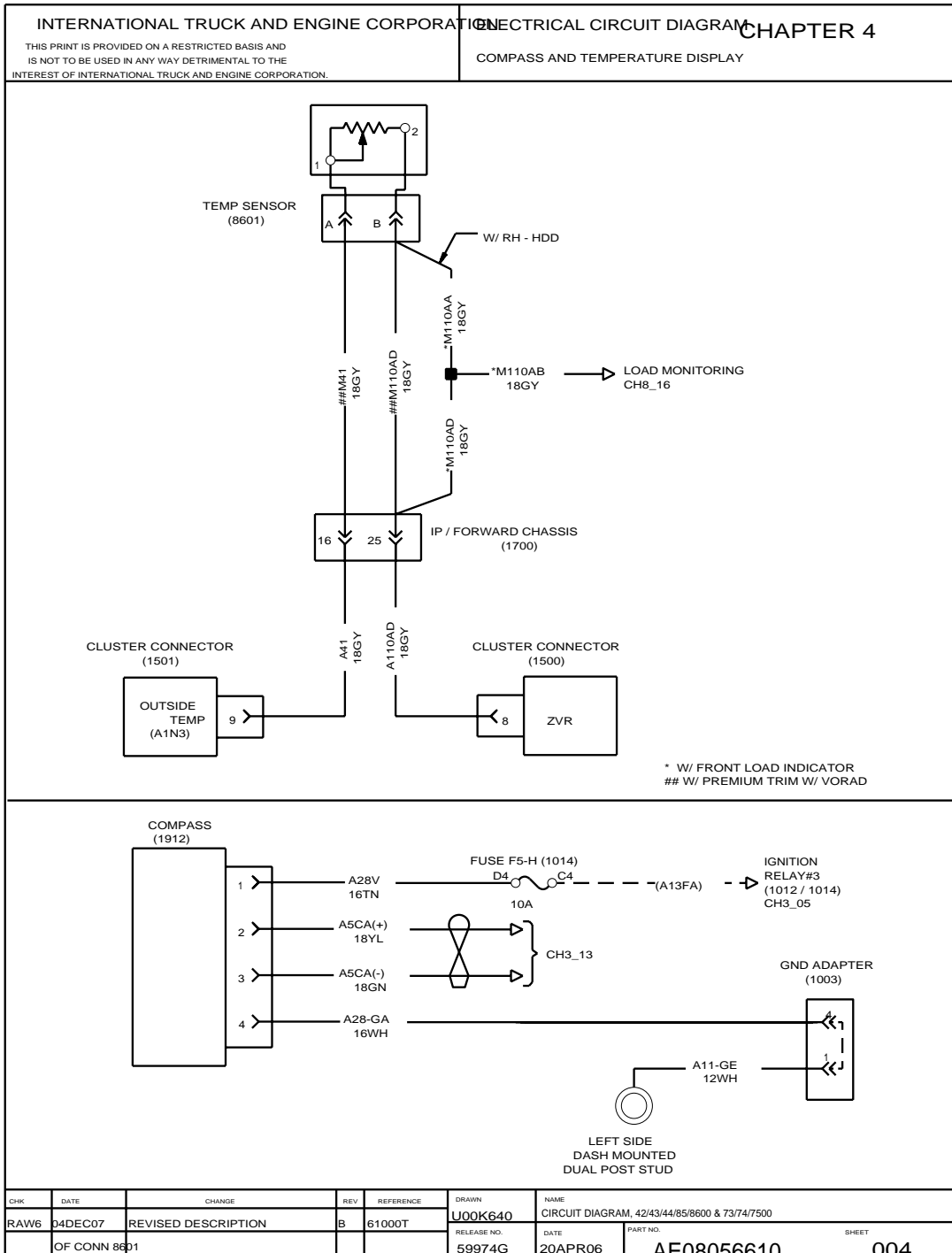

Figure 46 Compass and Temperature Display

4.5. FRONT DOOR WINDOWS AND LOCKS (POWER), P. 5

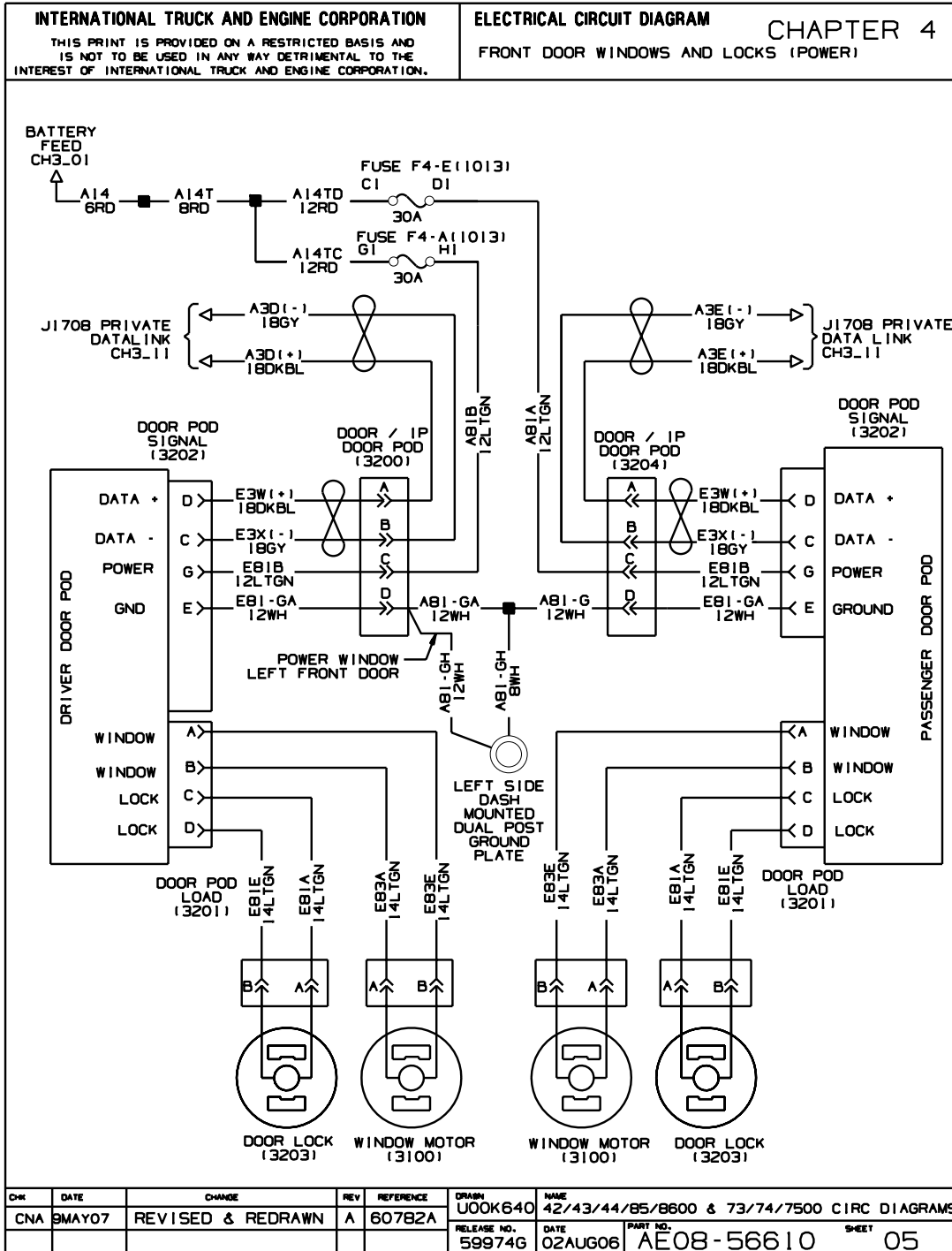

Figure 47 Front Door Windows and Locks (Power)

4.6. FRONT DOOR WINDOWS AND LOCKS (POWER) FOR CREW, P. 6

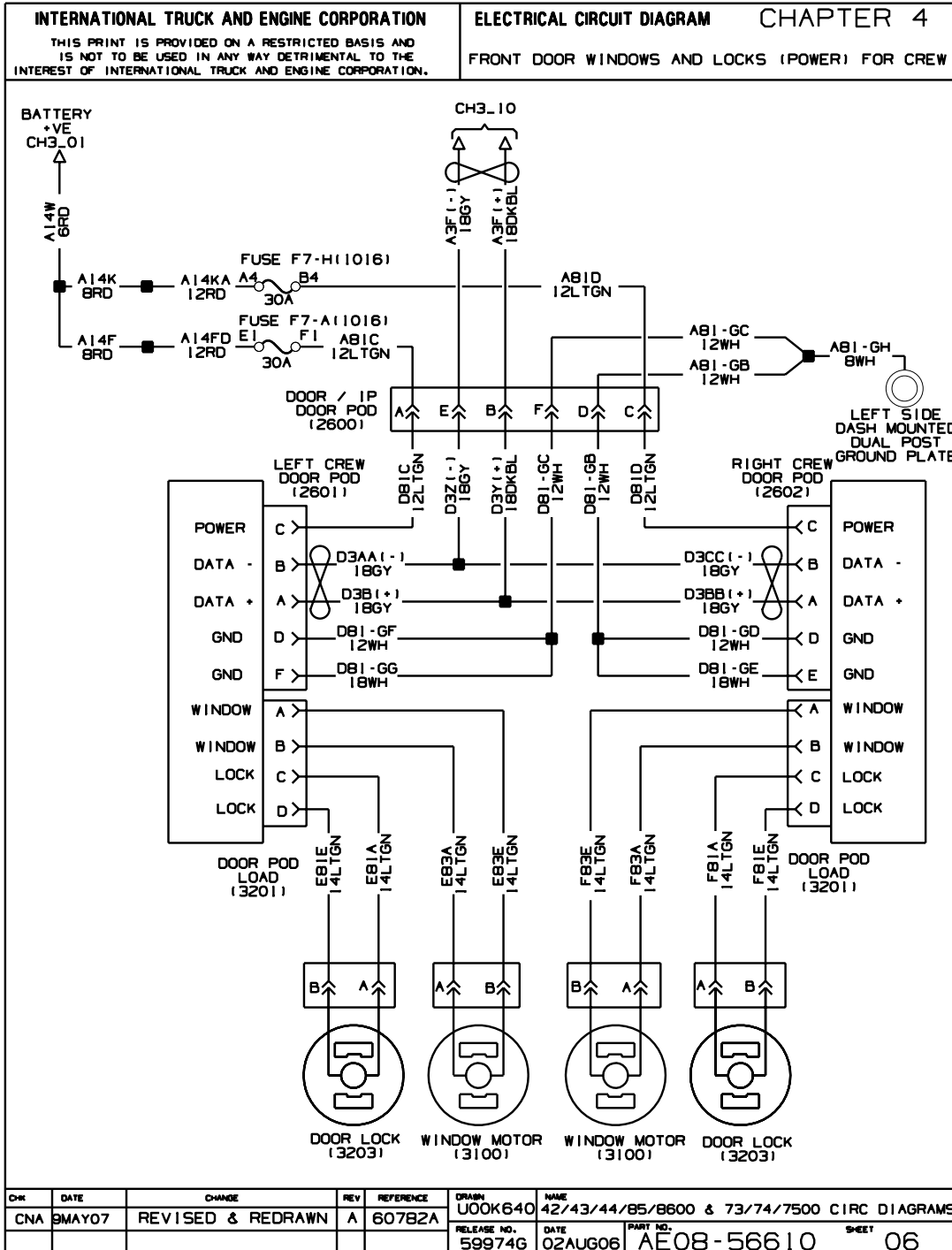

Figure 48 Front Door Windows and Locks (Power) for Crew

4.7. HORN, ELECTRIC AND AIR, P. 7

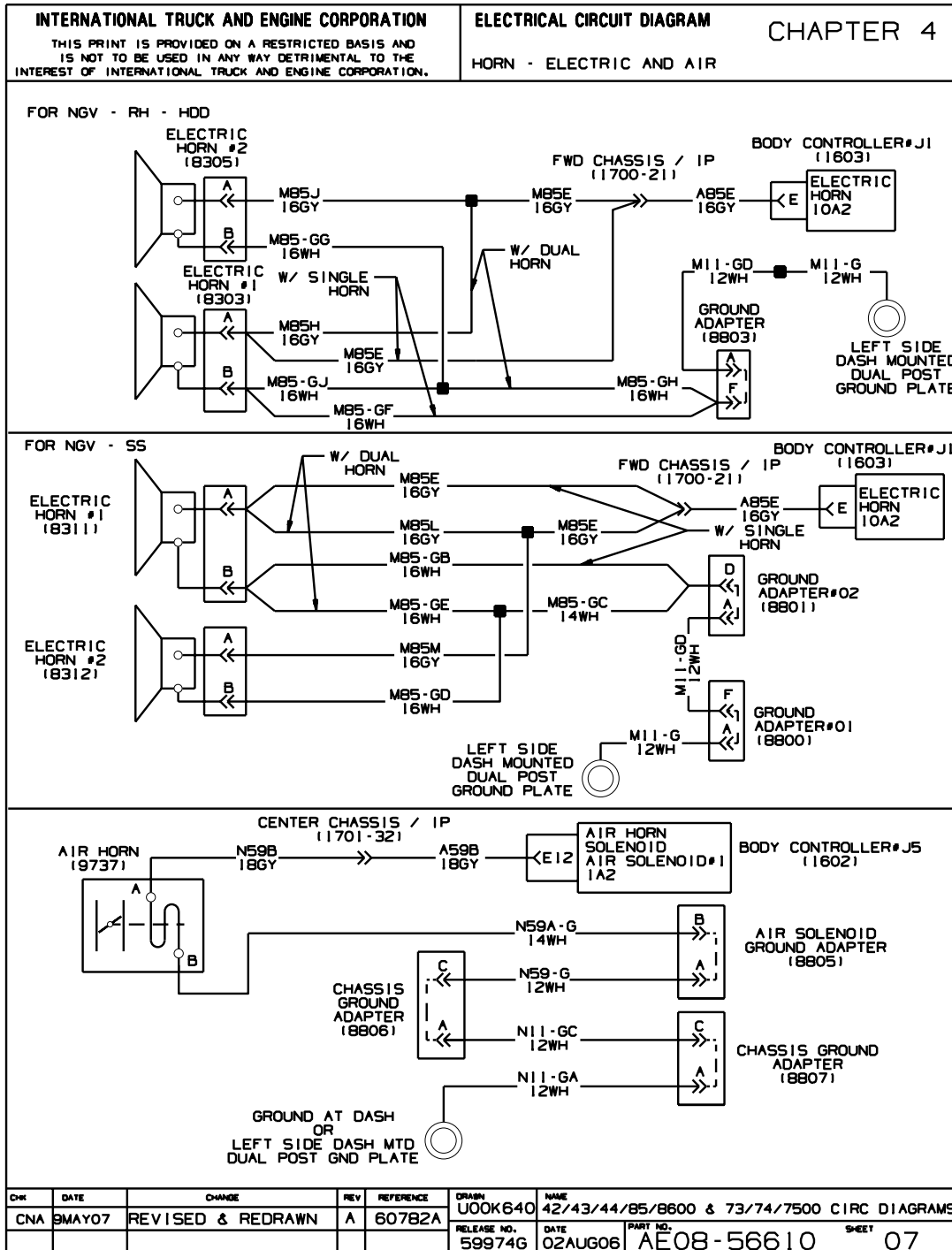

Figure 49 Horn, Electric and Air

4.8. HORN, ELECTRIC AND AIR, P. 8

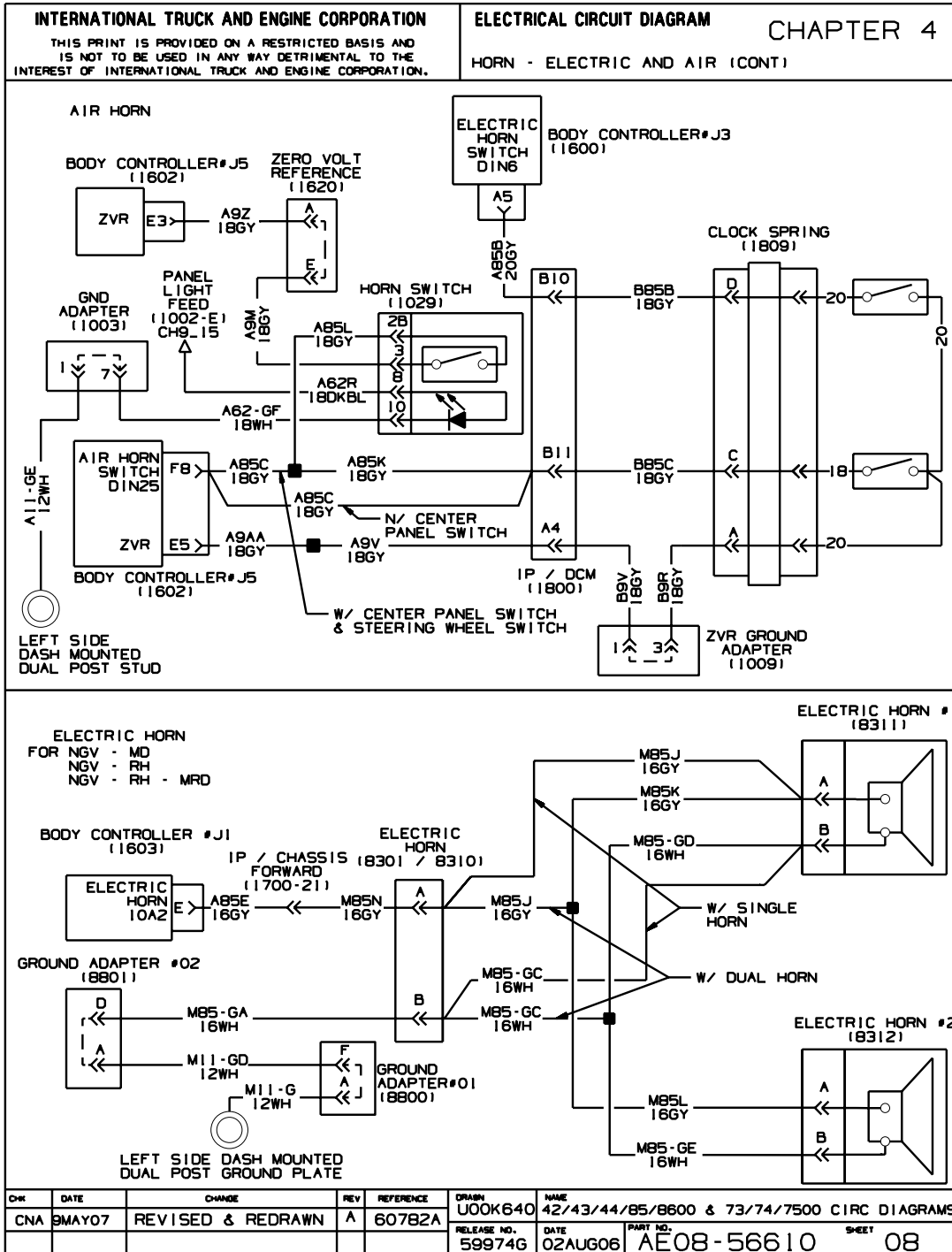

Figure 50 Horn, Electric and Air

4.9. MIRRORS (HEATED, LIGHTED AND POWER), P. 9

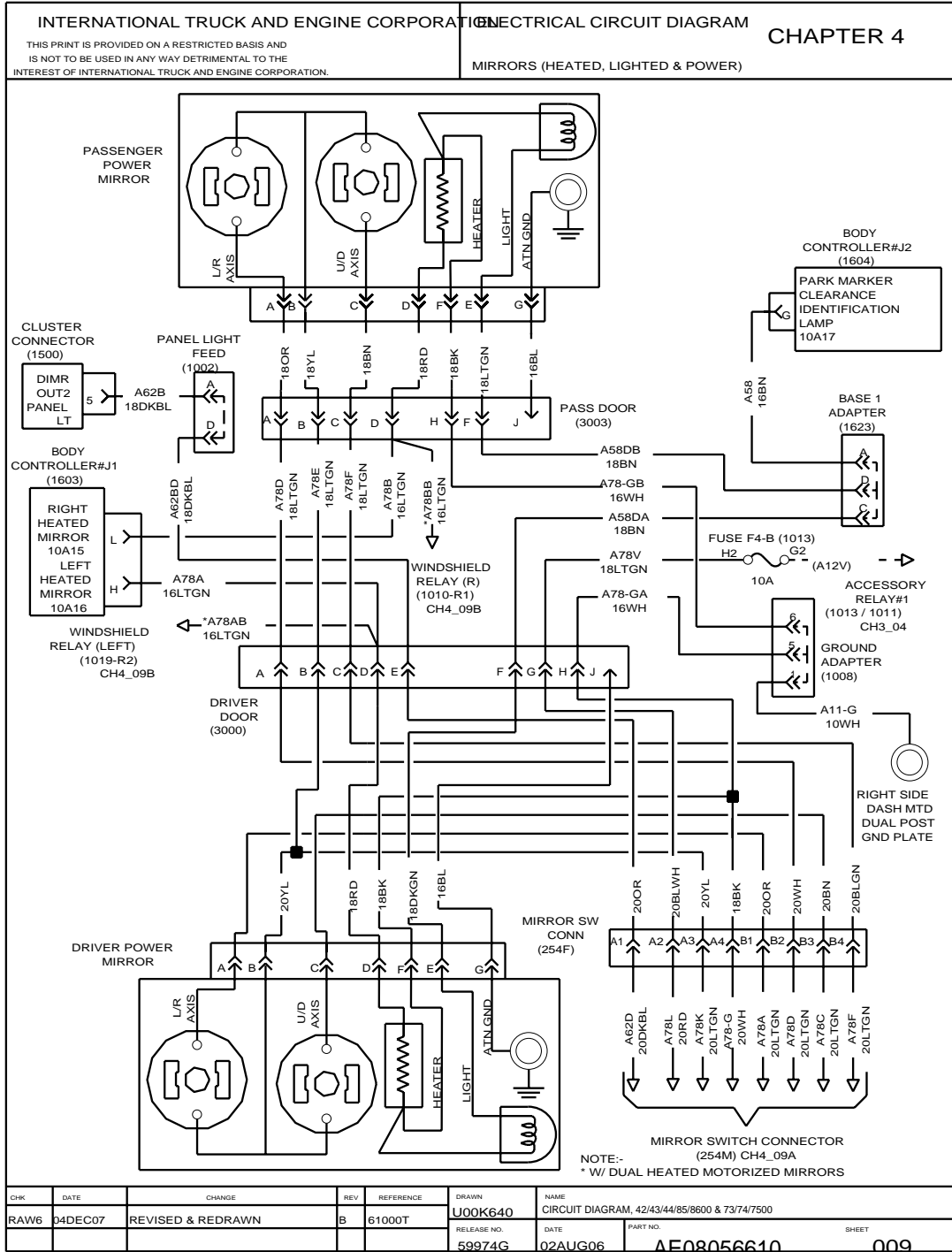

Figure 51 Mirrors (Heated, Lighted and Power)

4.10. MIRRORS (HEATED, LIGHTED AND POWER), P. 9A

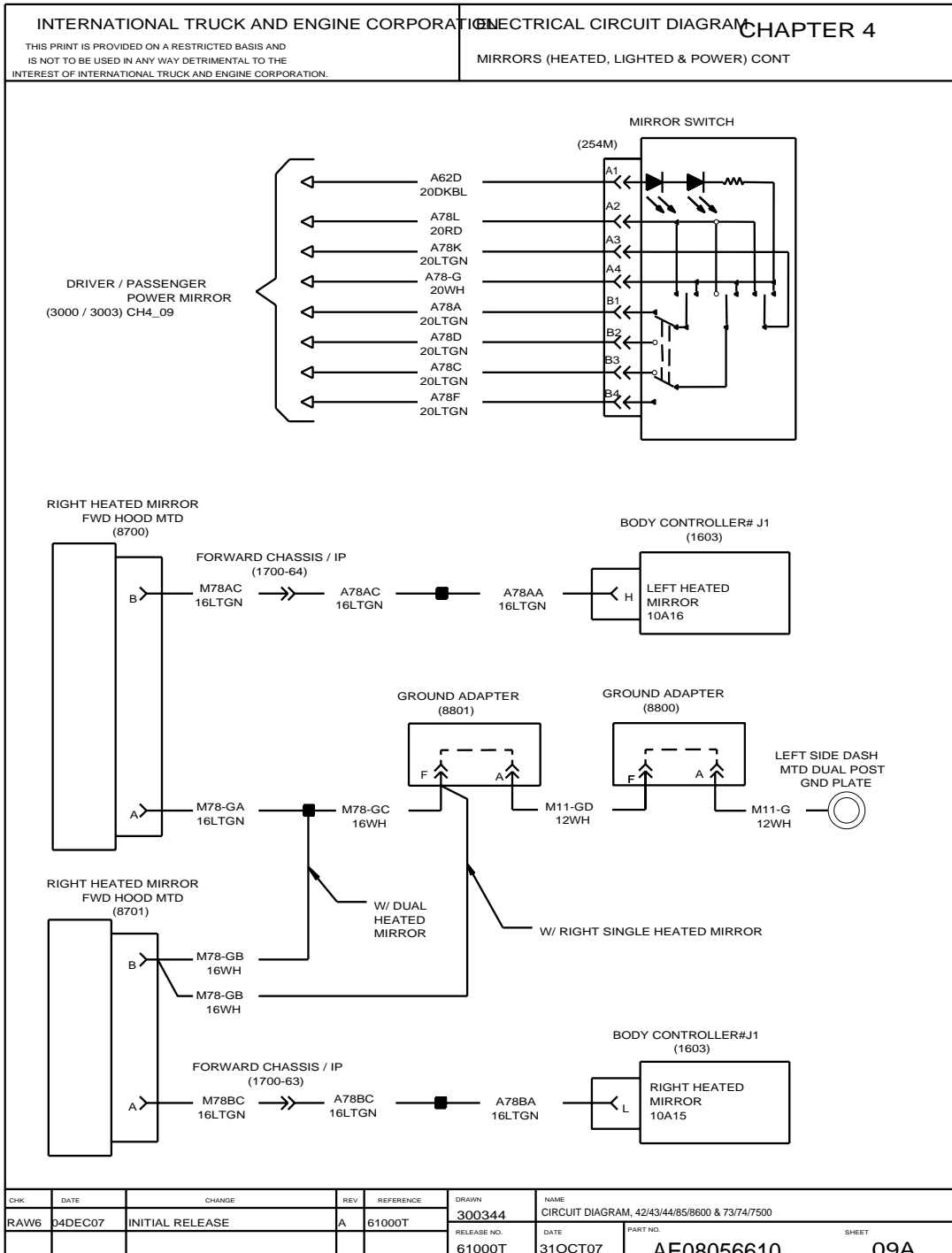

Figure 52 Mirrors (Heated, Lighted and Power)

4.11. DUAL HEATED MOTORIZED MIRRORS WITH HEATED WINDSHIELD, P. 9B

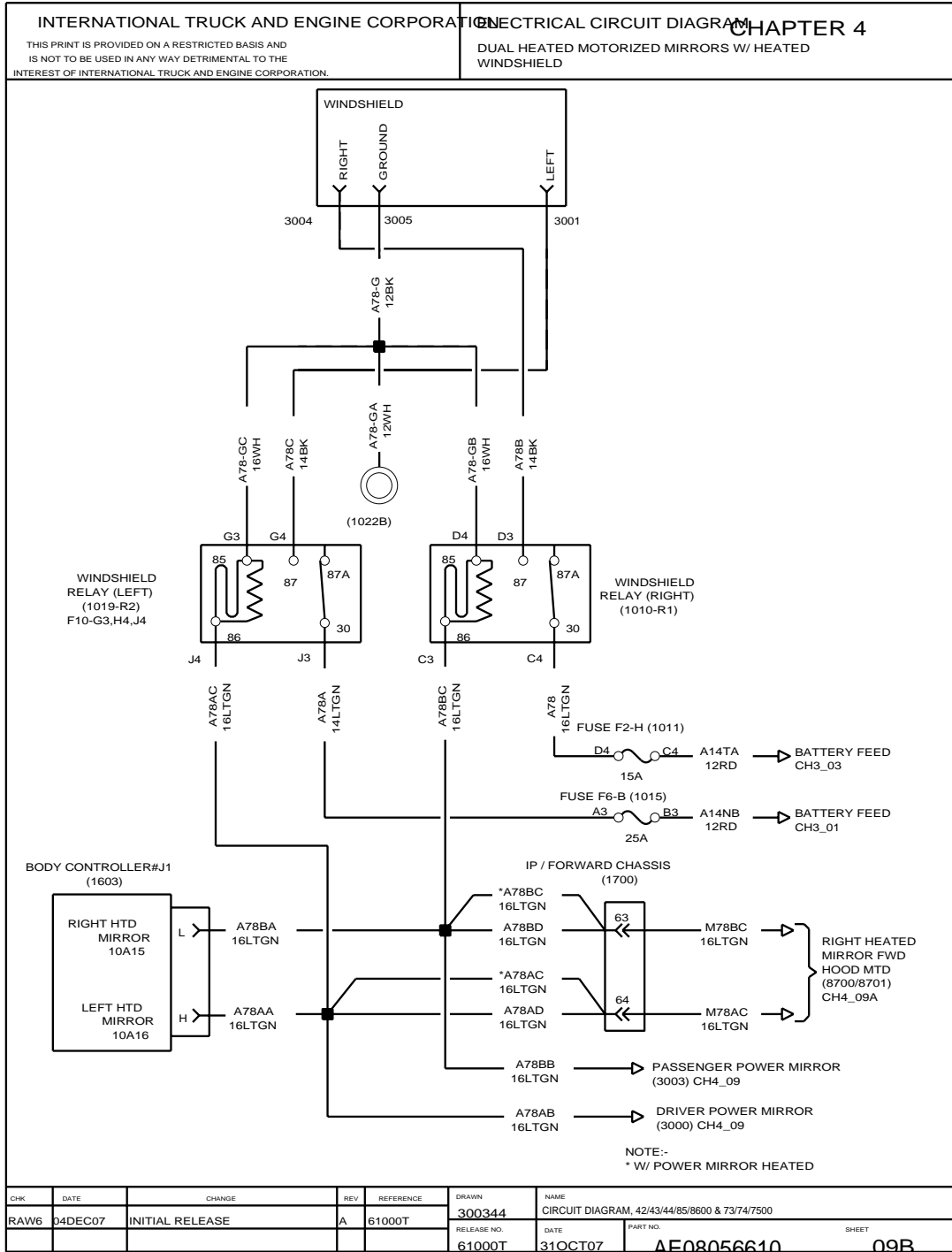

Figure 53 Dual Heated Motorized Mirrors with Heated Windshield

4.12. RADIO (ENTERTAINMENT), SPEAKERS WITH 12 WAY CONN, P. 10

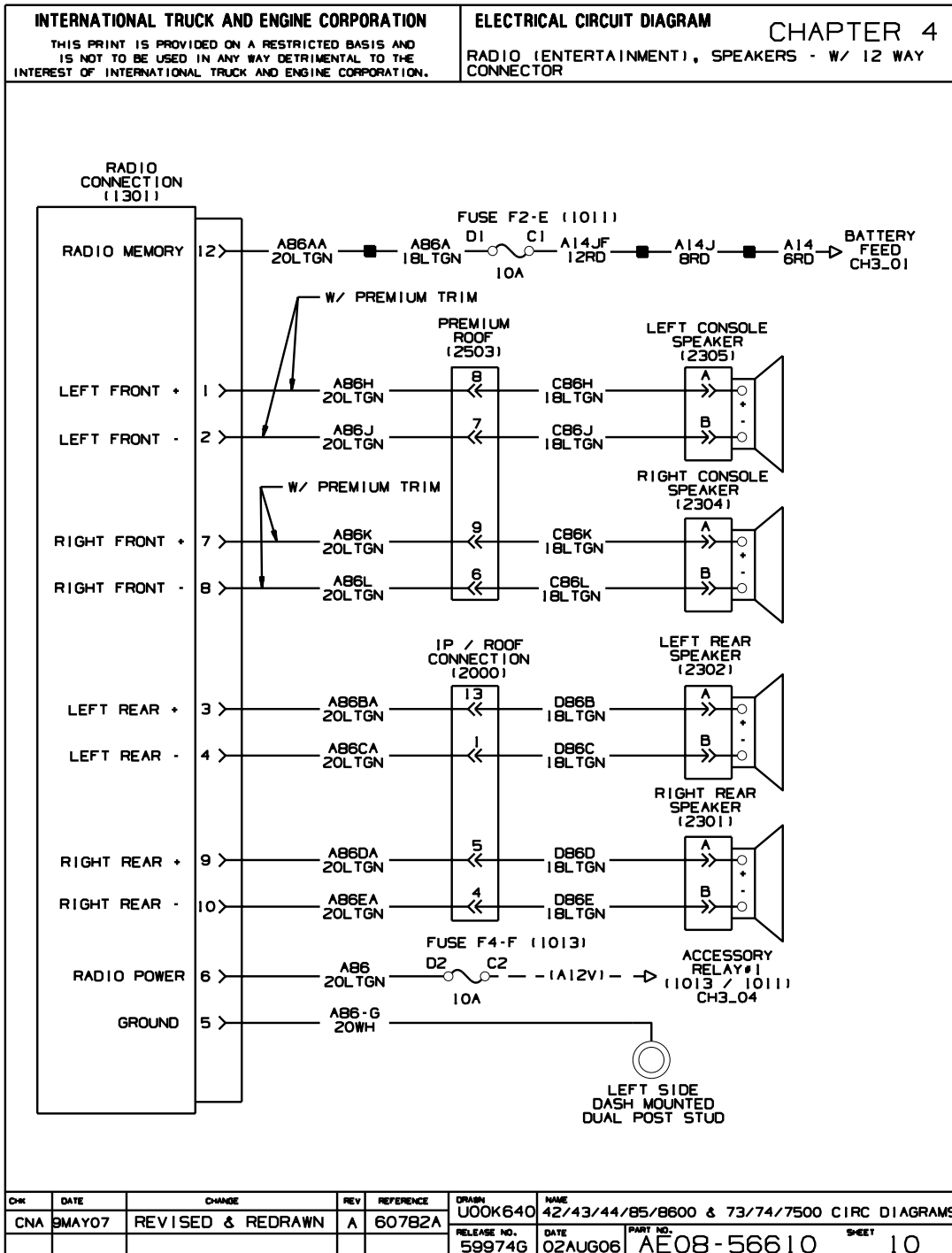

Figure 54 Radio (Entertainment), Speakers with 12 Way Conn

4.13. RADIO (ENTERTAINMENT), SPEAKERS WITH 16 WAY CONN, P. 11

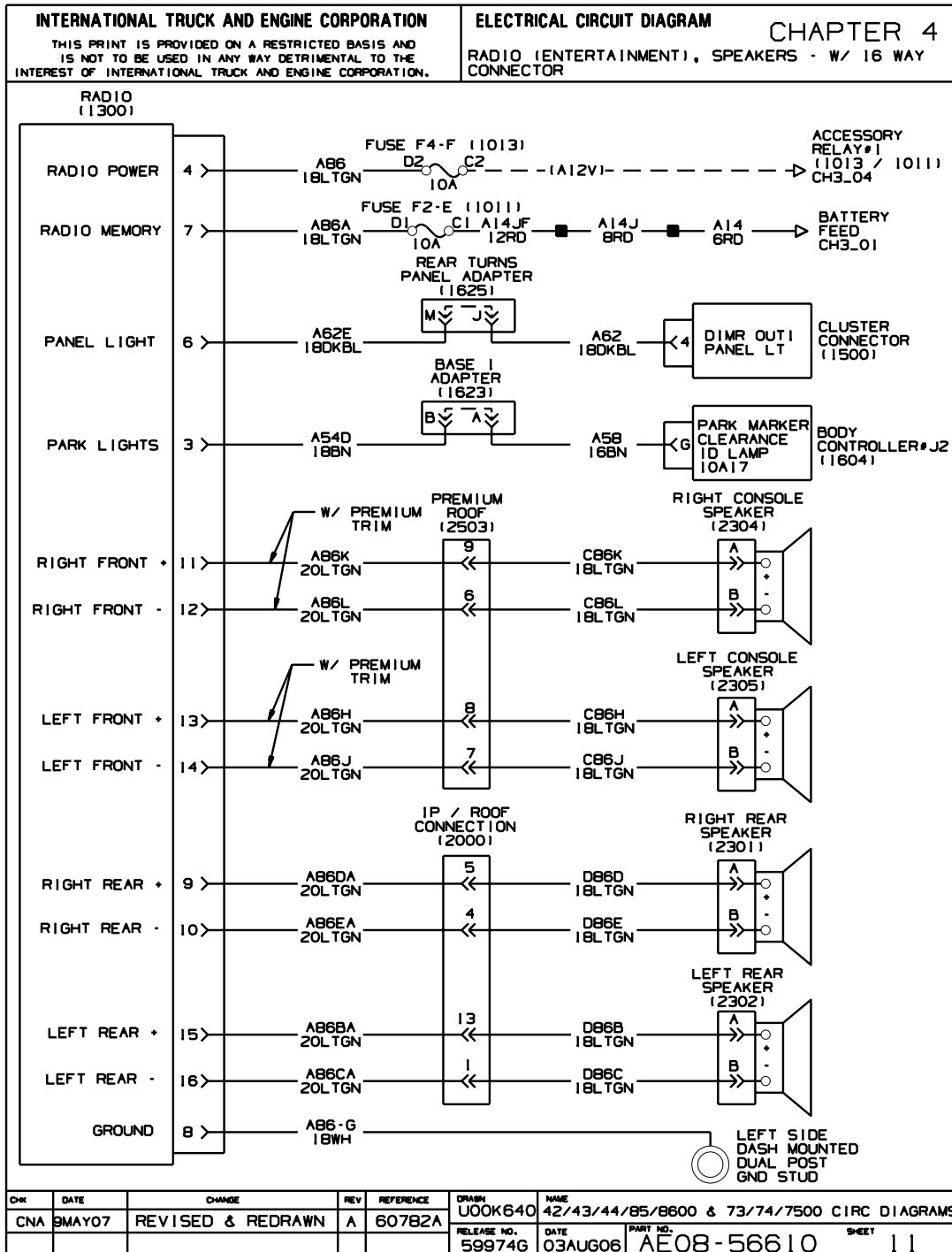

Figure 55 Radio (Entertainment), Speakers with 16 Way Connector

4.14. 2-WAY RADIO, P. 12

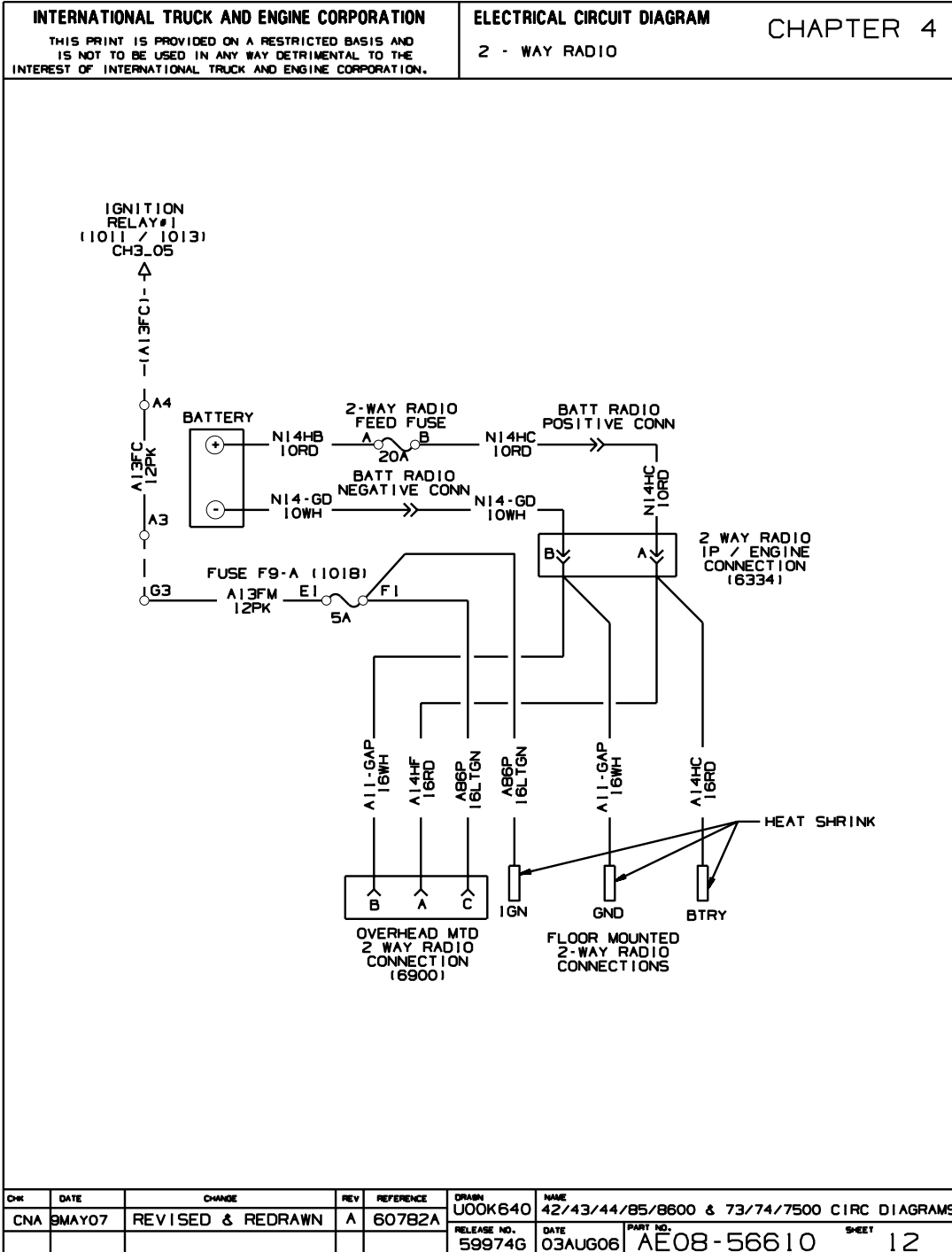

Figure 56 2-Way Radio

4.15. WINDSHIELD WIPER, P. 13

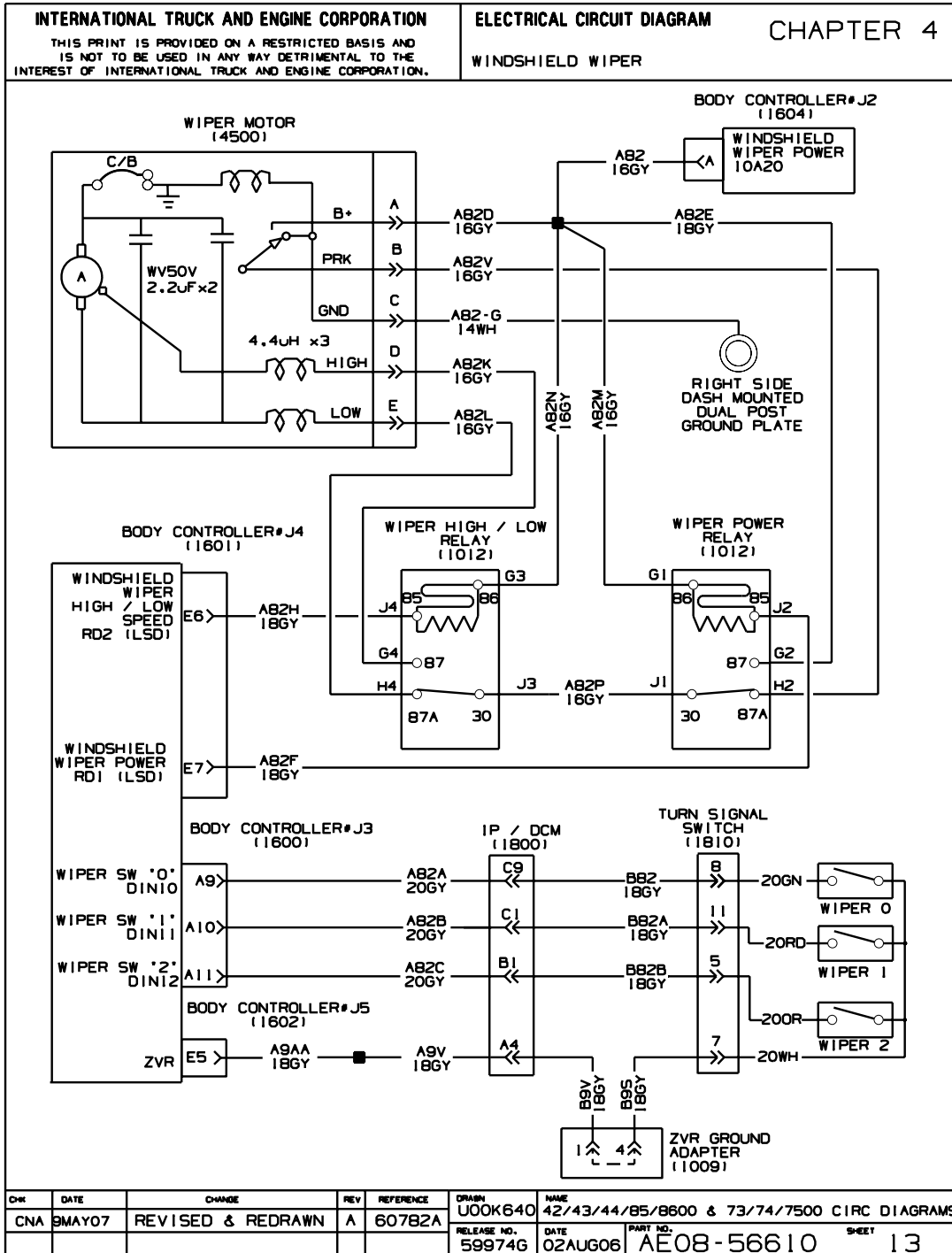

Figure 57 Windshield Wiper

4.16. WASHER PUMP, P. 14

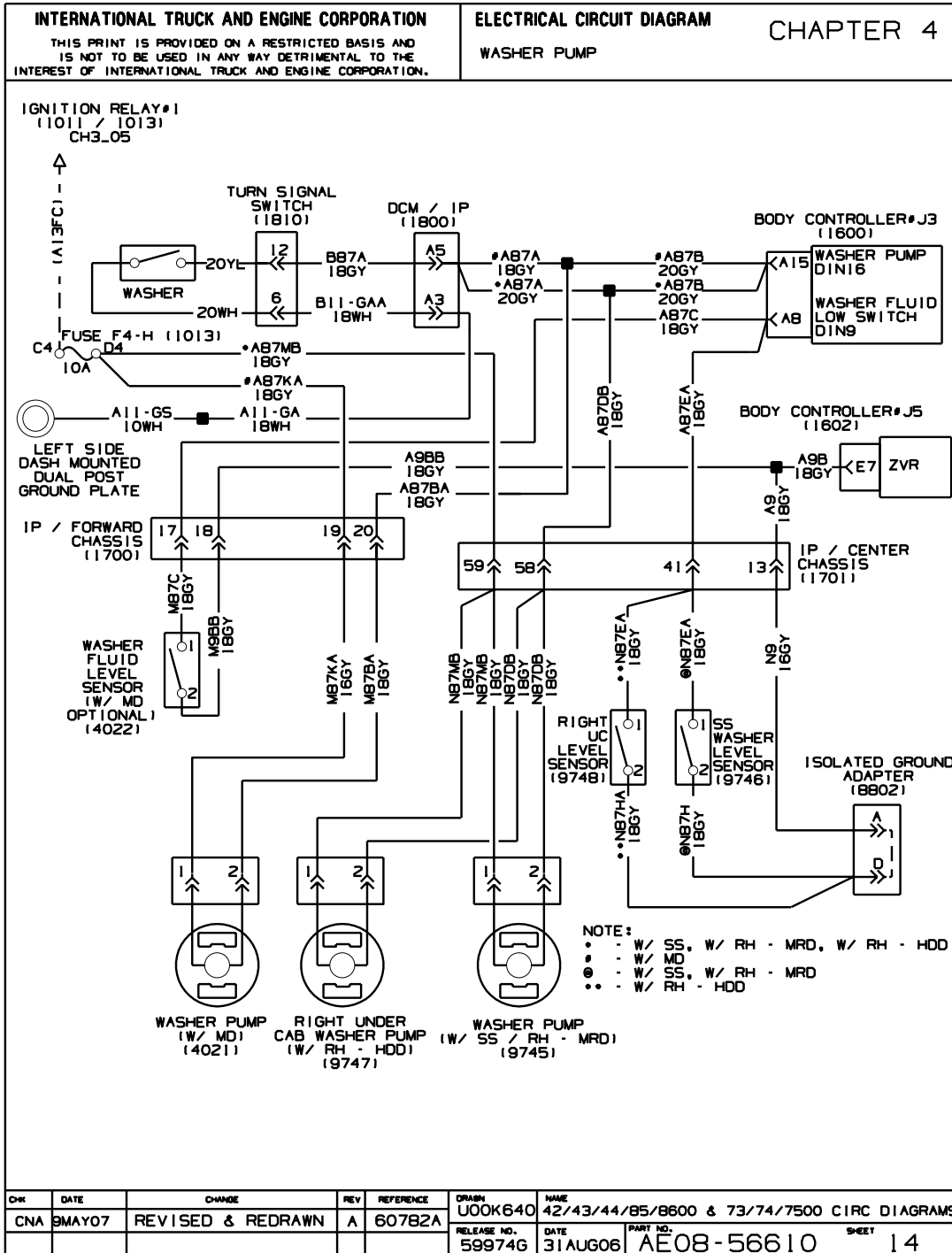

Figure 58 Washer Pump

4.17. SWITCH PACK OPTIONAL GAUGE PACK, P. 15

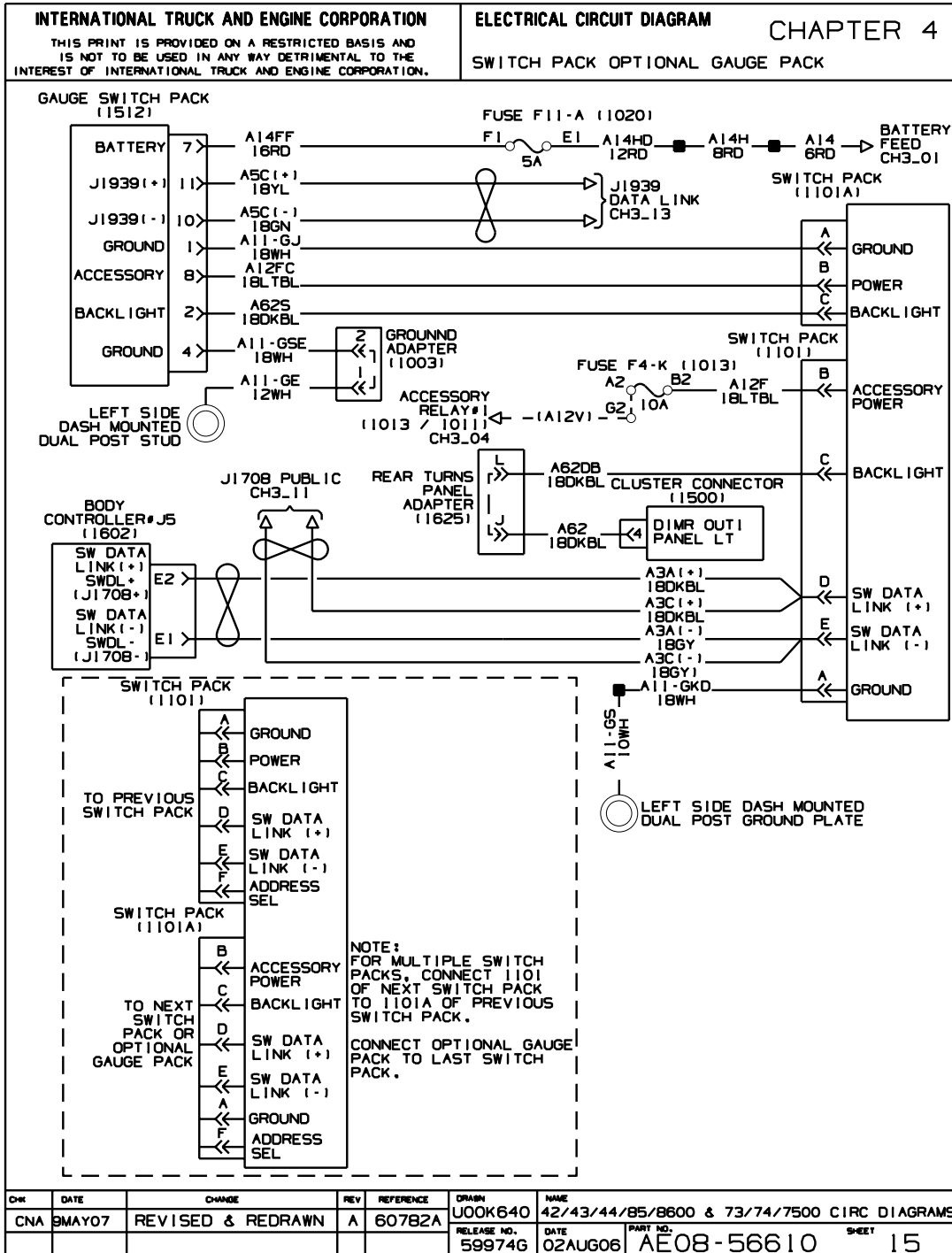

Figure 59 Switch Pack Optional Gauge Pack

4.18. ROOF AUXILIARY LOAD, P. 16

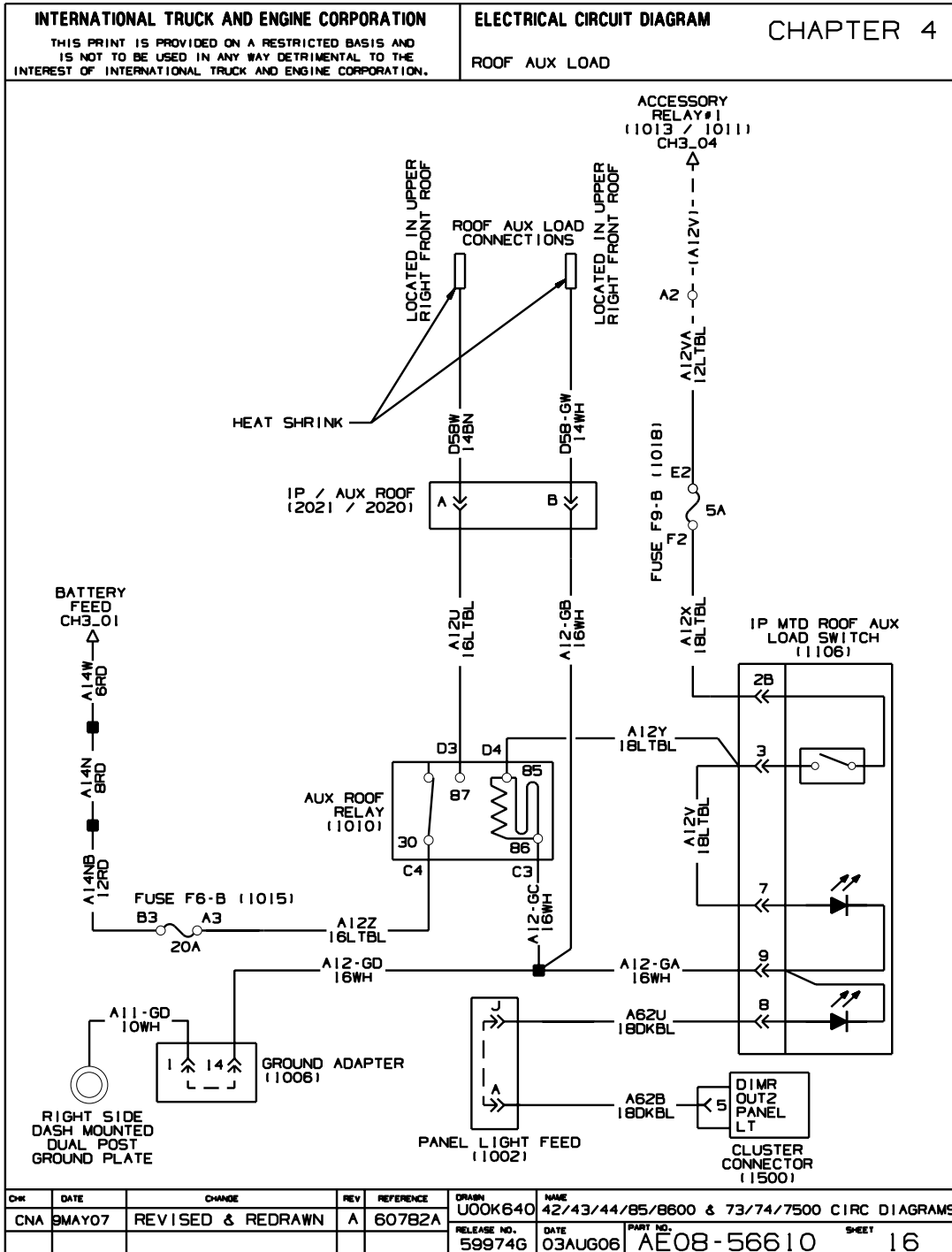

Figure 60 Roof Auxiliary Load

4.19. SATELLITE COMMUNICATION — QUALCOMM IMCT, P. 17

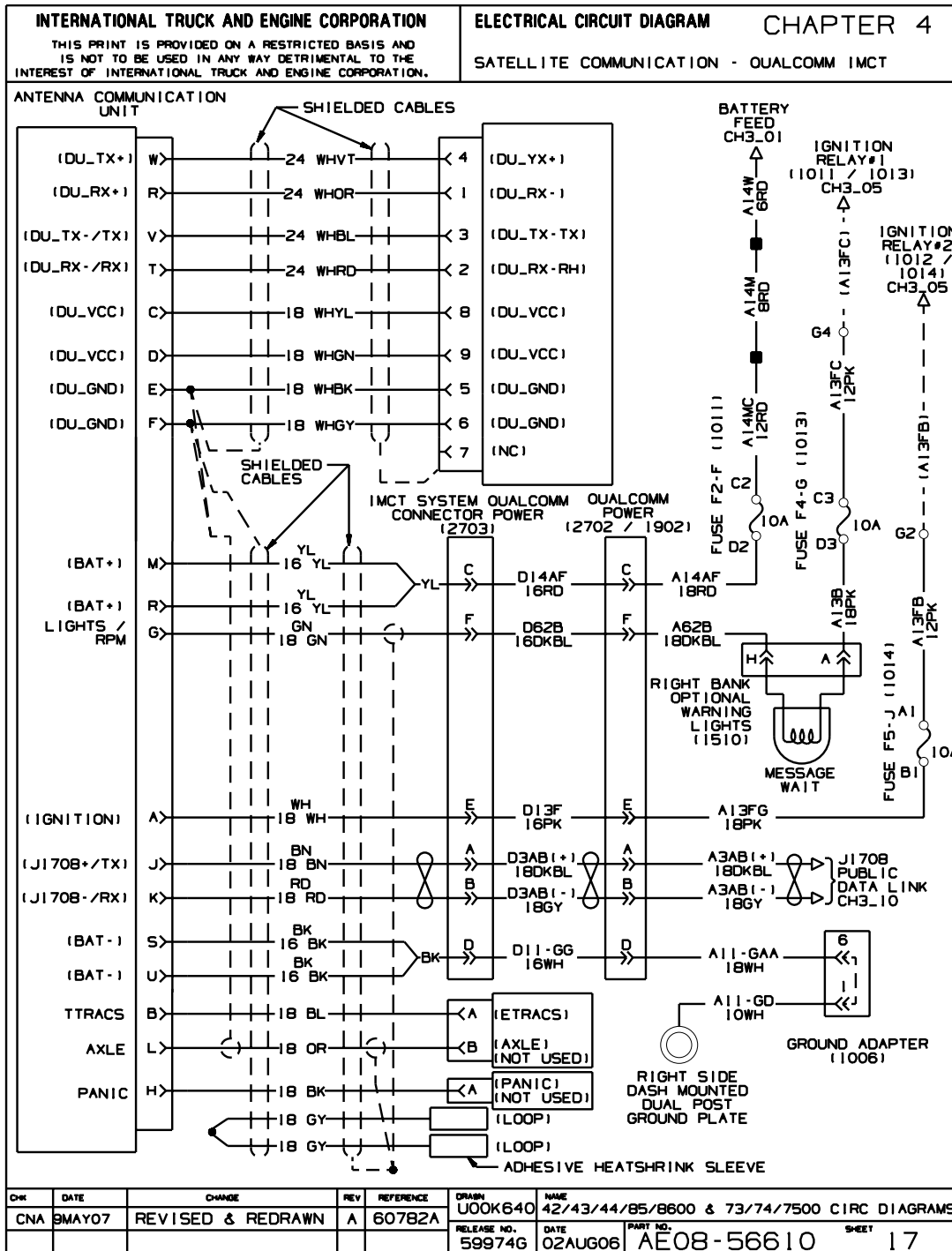

Figure 61 Satellite Communication — Qualcomm IMCT

4.20. SATELLITE COMMUNICATION — TRIPMASTER, P. 18

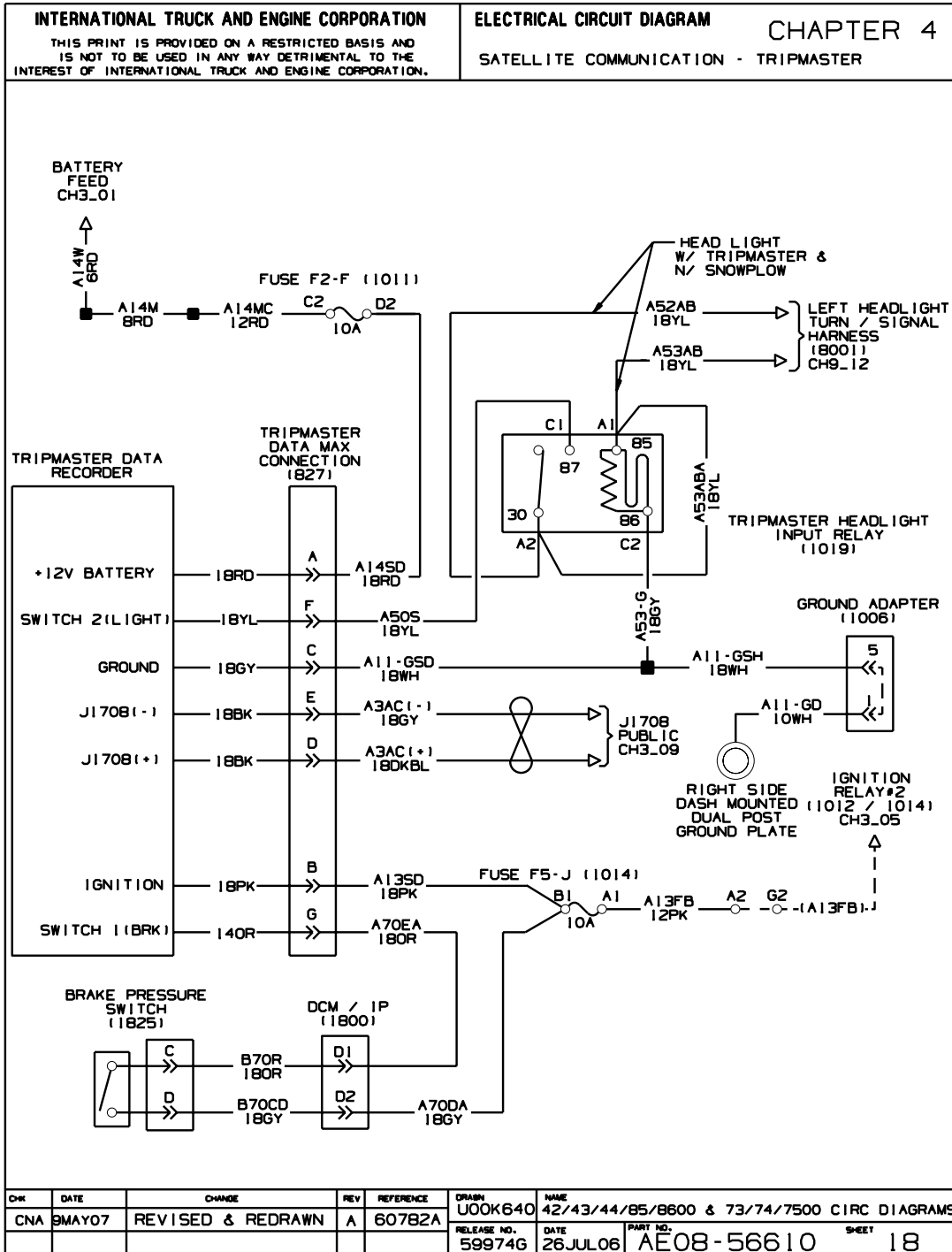

Figure 62 Satellite Communication — Tripmaster

4.21. COMPUTER PREWIRED — XATA SYSTEM, P. 19

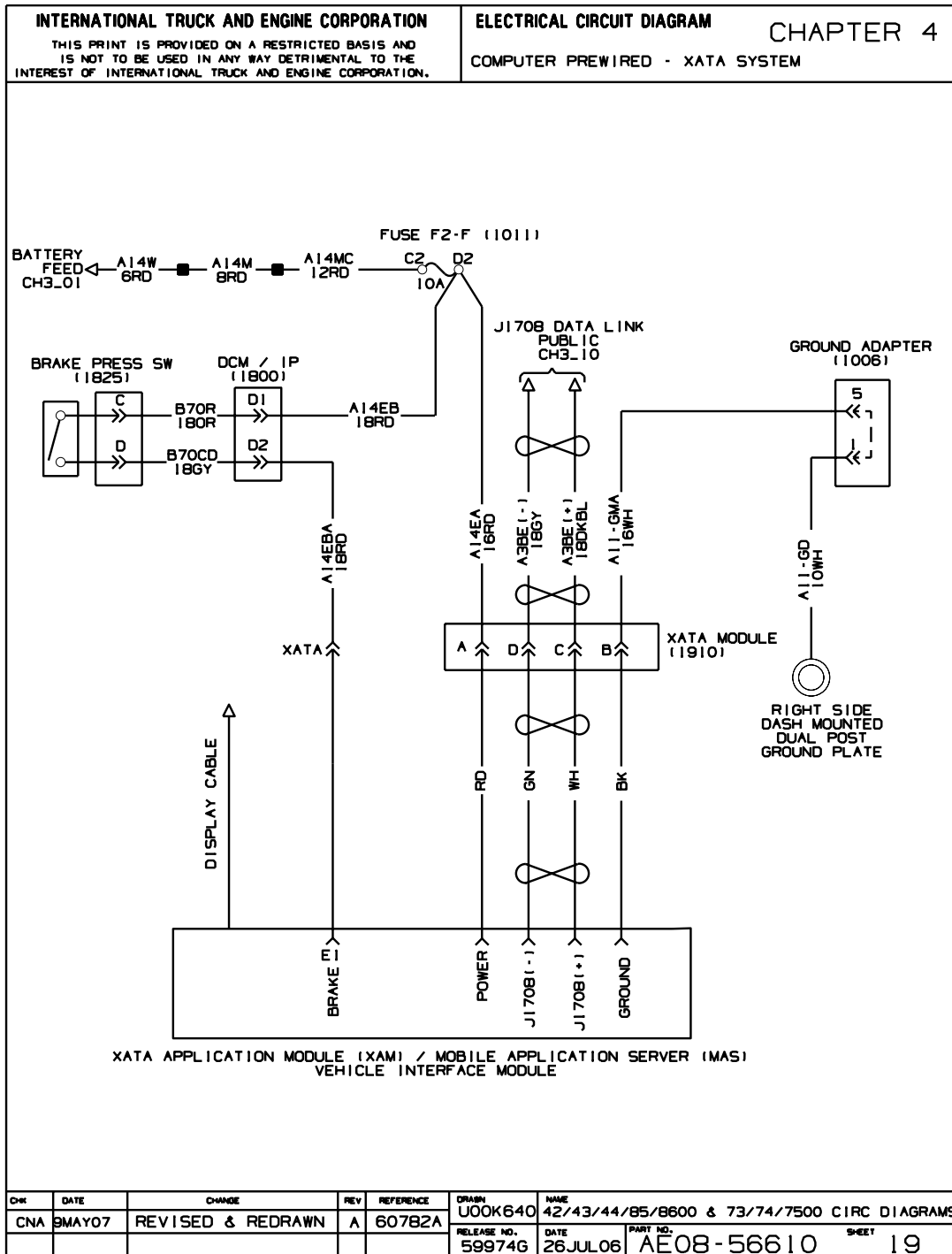

Figure 63 Computer Prewired — XATA System

4.22. CADEC GPS SYSTEM, P. 20

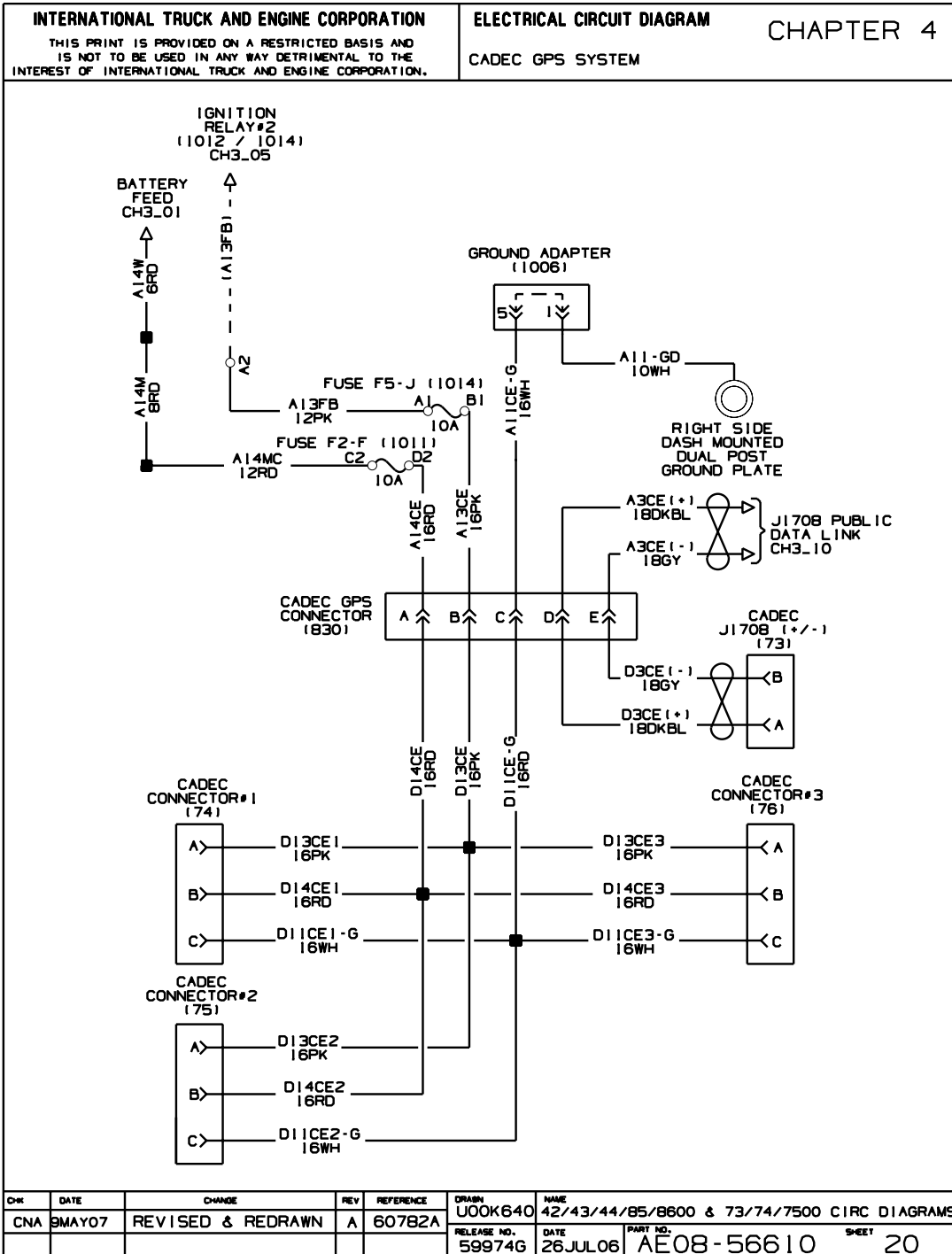

Figure 64 Cadec GPS System

4.23. SATELLITE COMMUNICATION — MOBILEMAX, P. 21

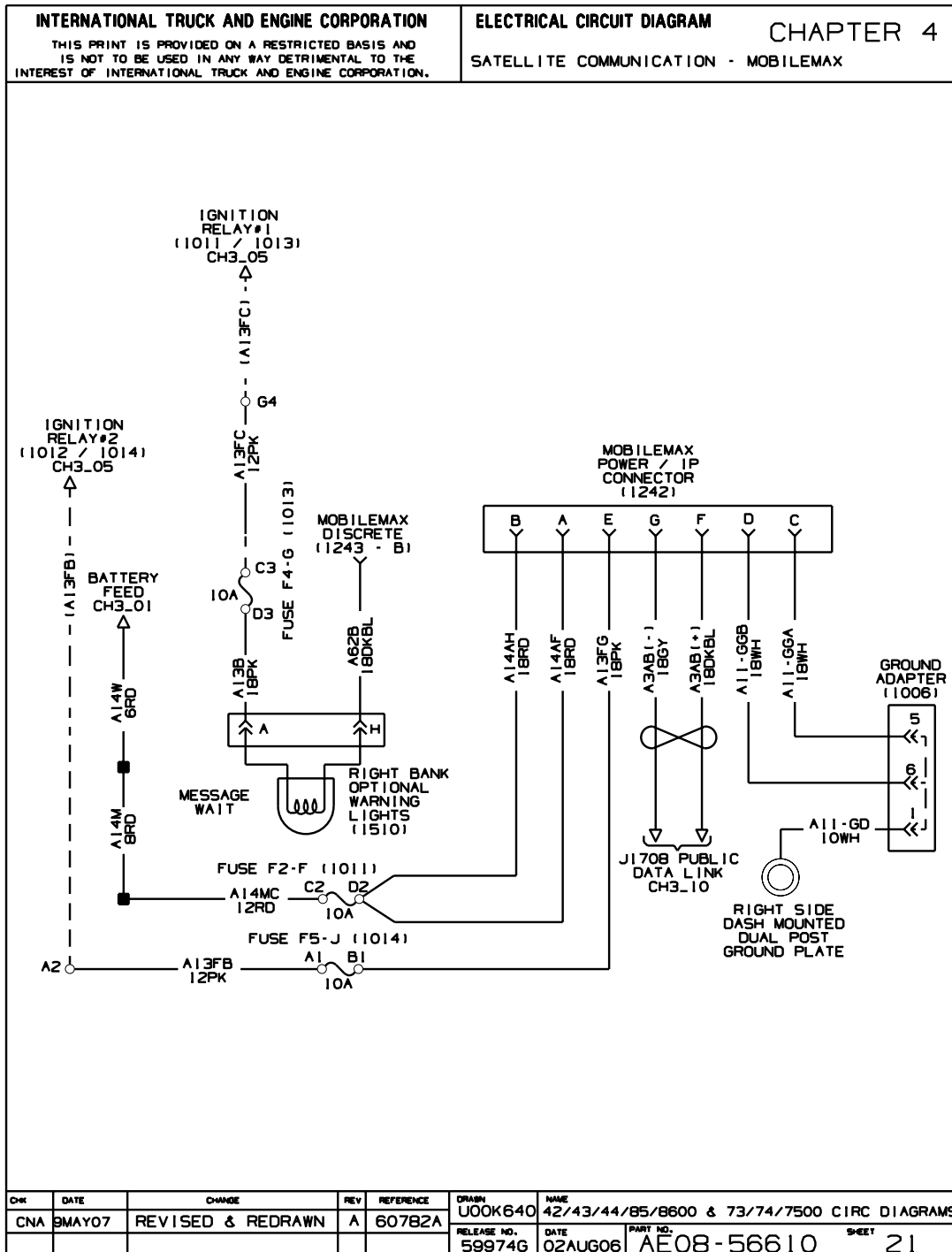

Figure 65 Satellite Communication — MobileMax

4.24. SELF CONTAINED AIR SEAT, P. 22

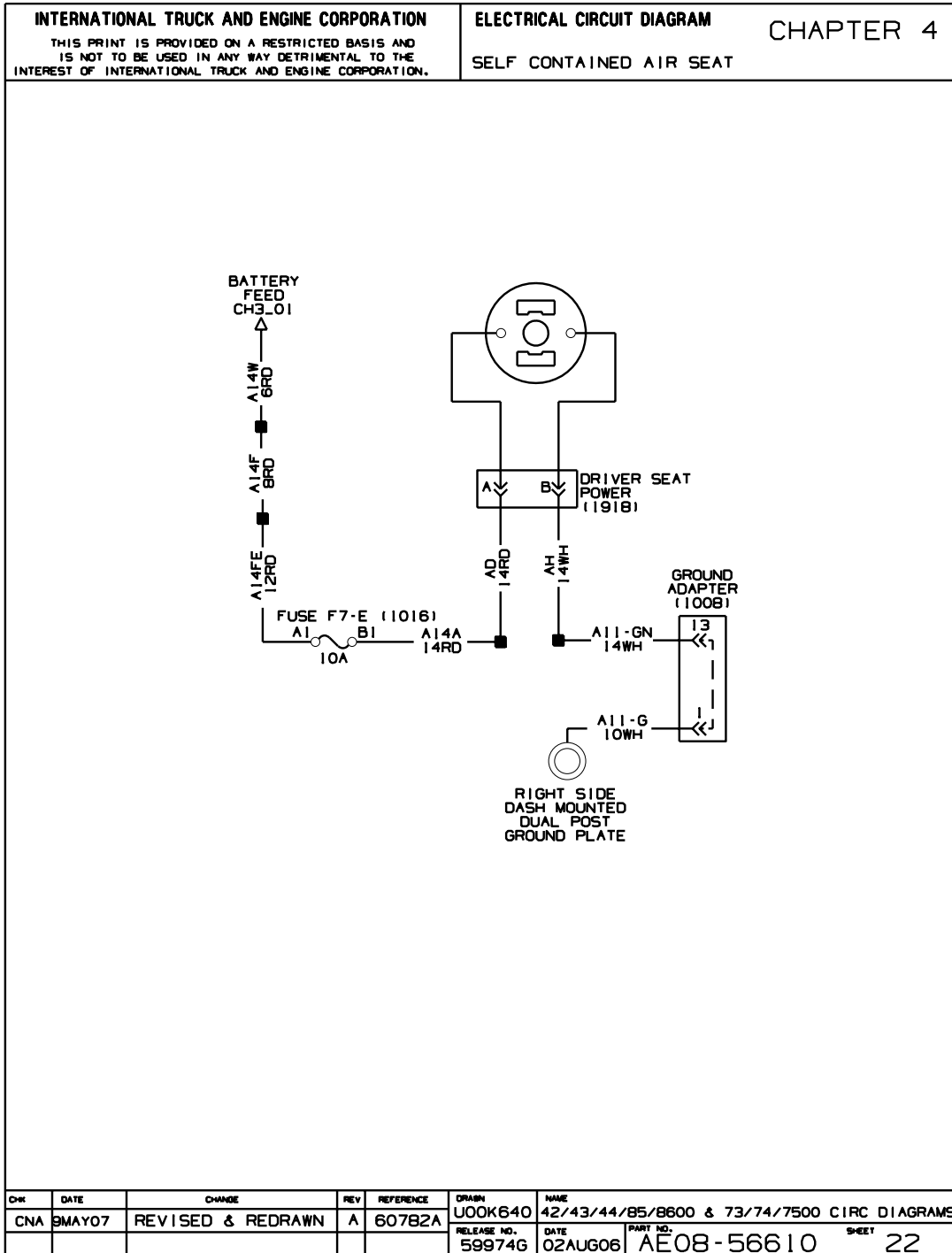

Figure 66 Self Contained Air Seat

4.25. HEATED SEATS, P. 23

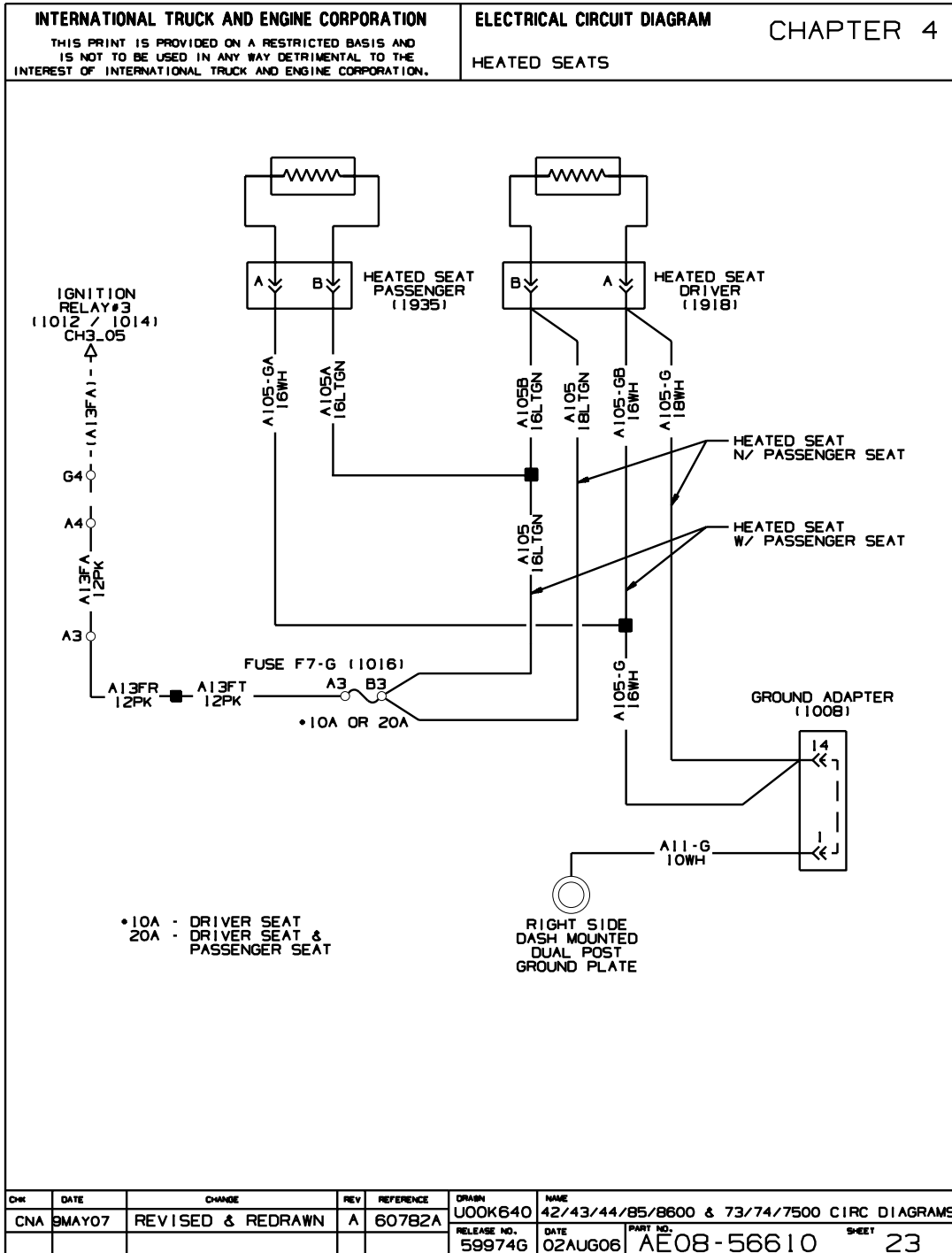

Figure 67 Heated Seats

4.26. TELEMATICS SYSTEM, P. 24

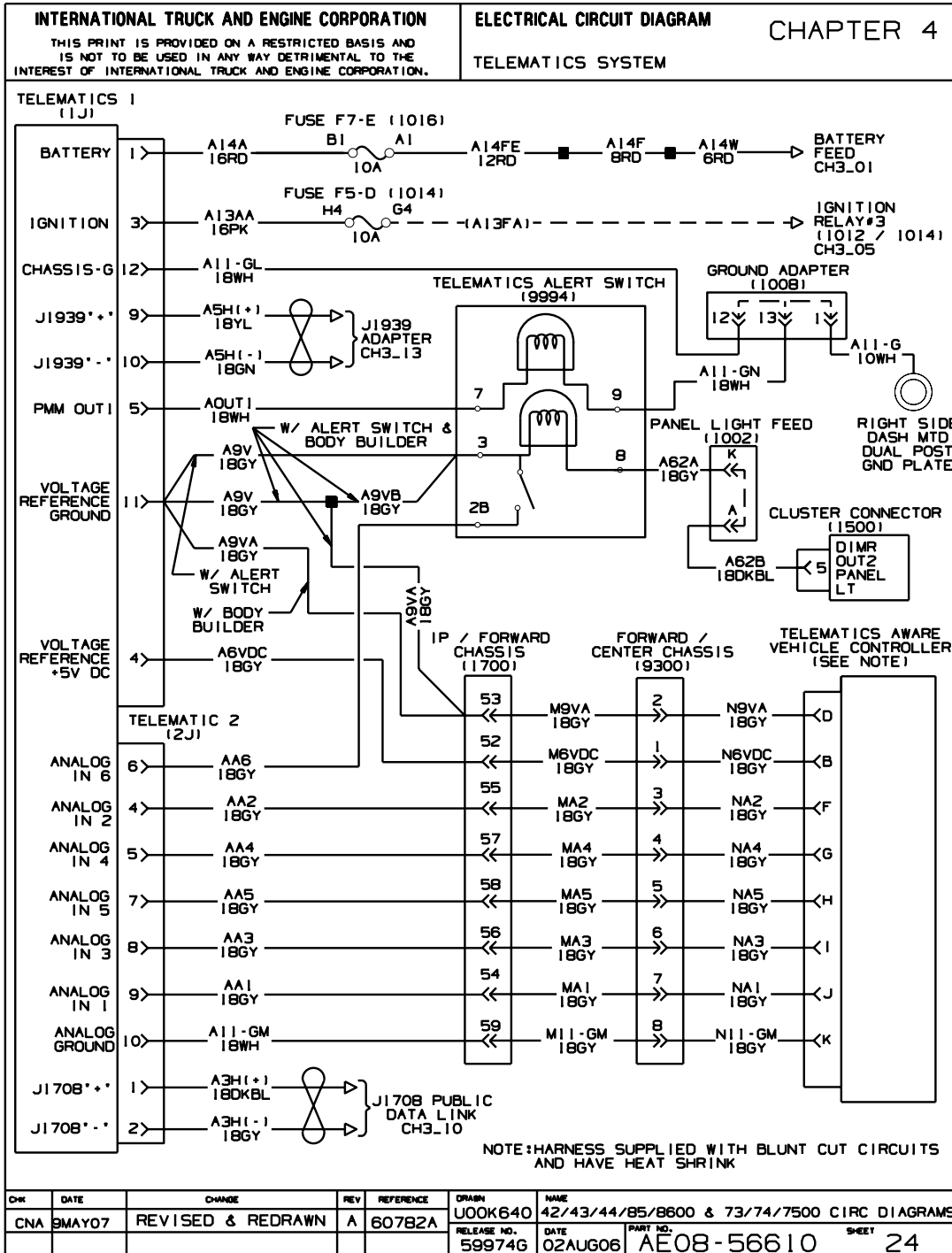

Figure 68 Telematics System

4.27. EATON VORAD COLLISION AVOIDANCE SYSTEM, P. 25

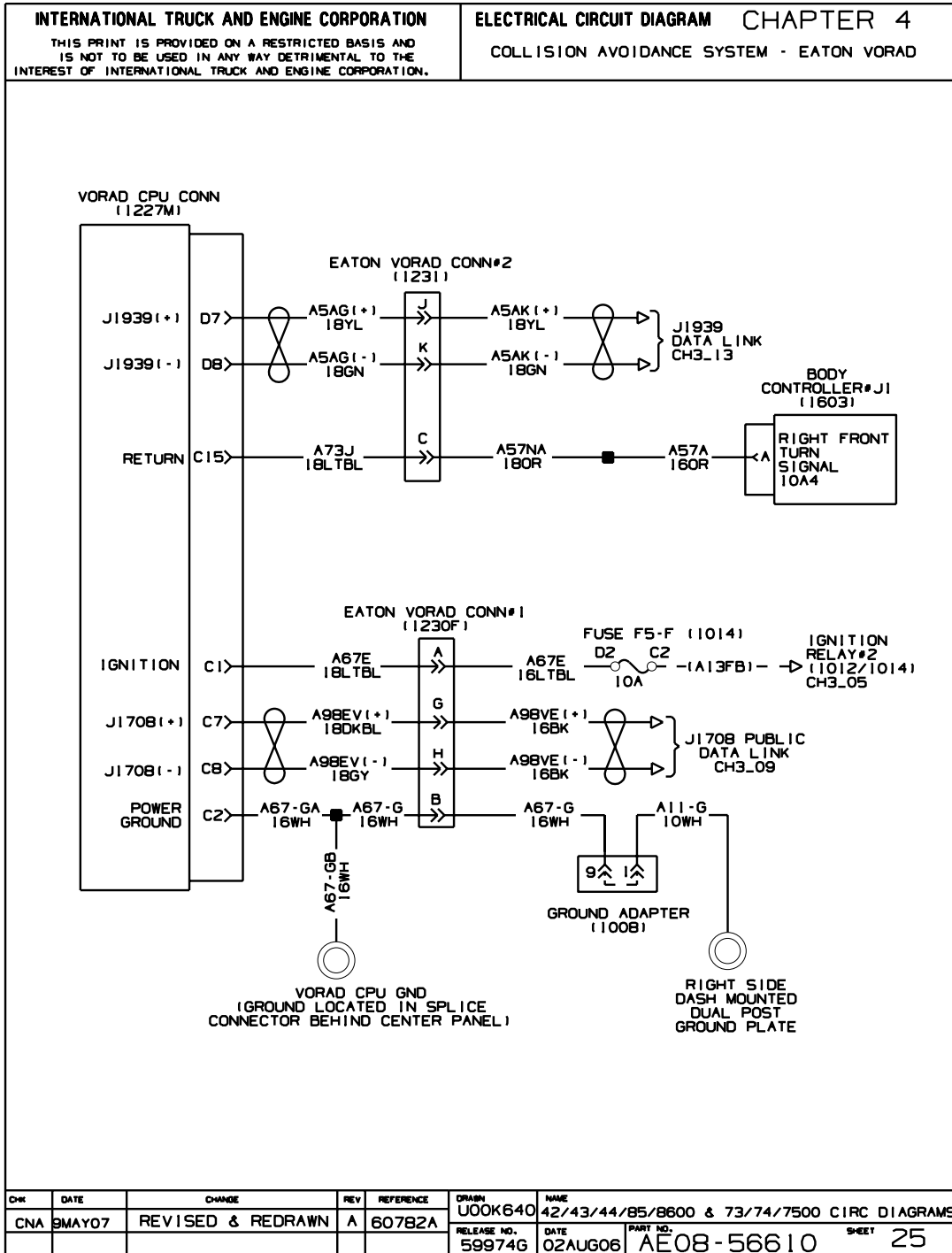

Figure 69 Eaton Vorad Collision Avoidance System

4.28. EATON VORAD COLLISION AVOIDANCE SYSTEM, P. 26

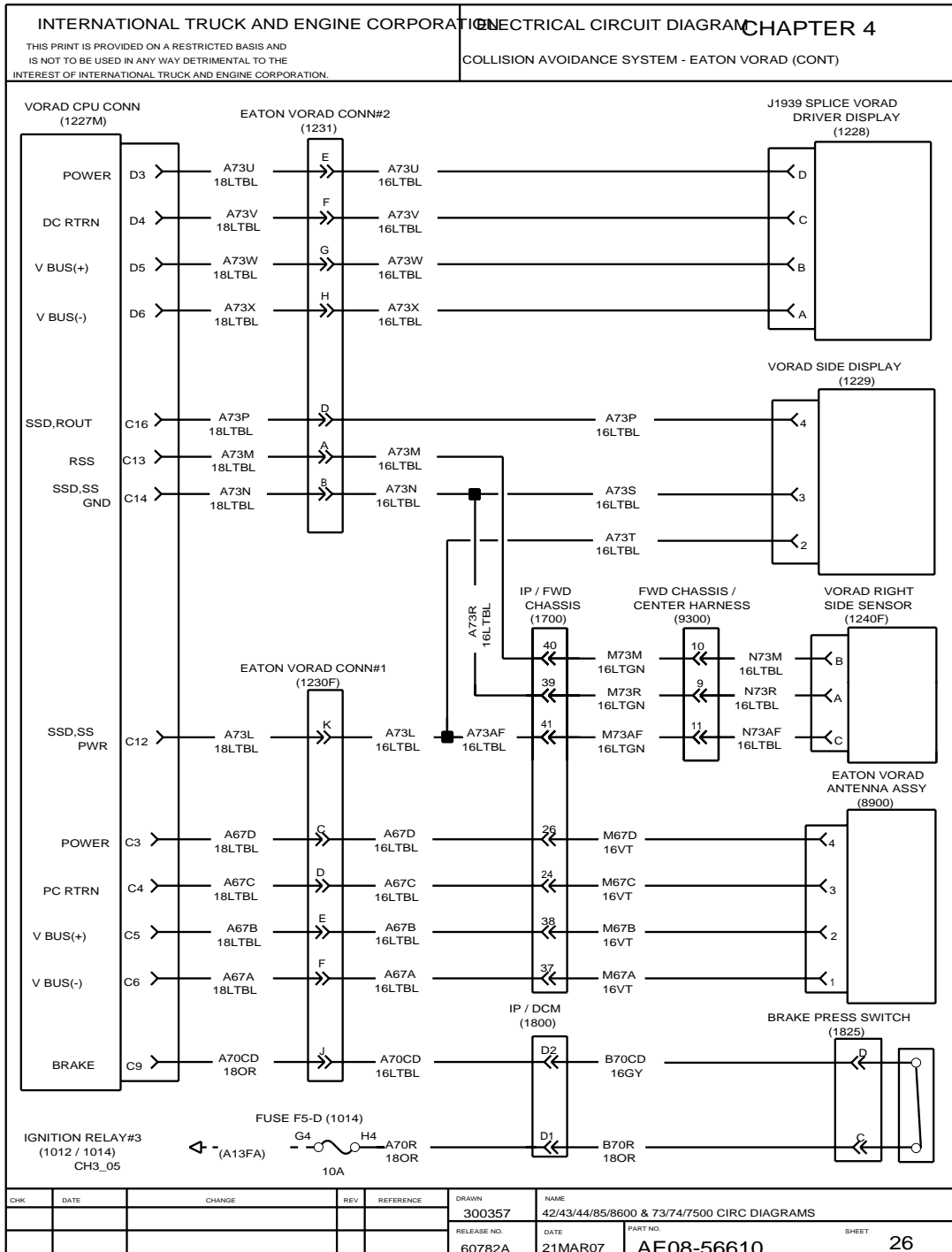

Figure 70 Eaton Vorad Collision Avoidance System

4.29. DRIVER DISPLAY, P. 27

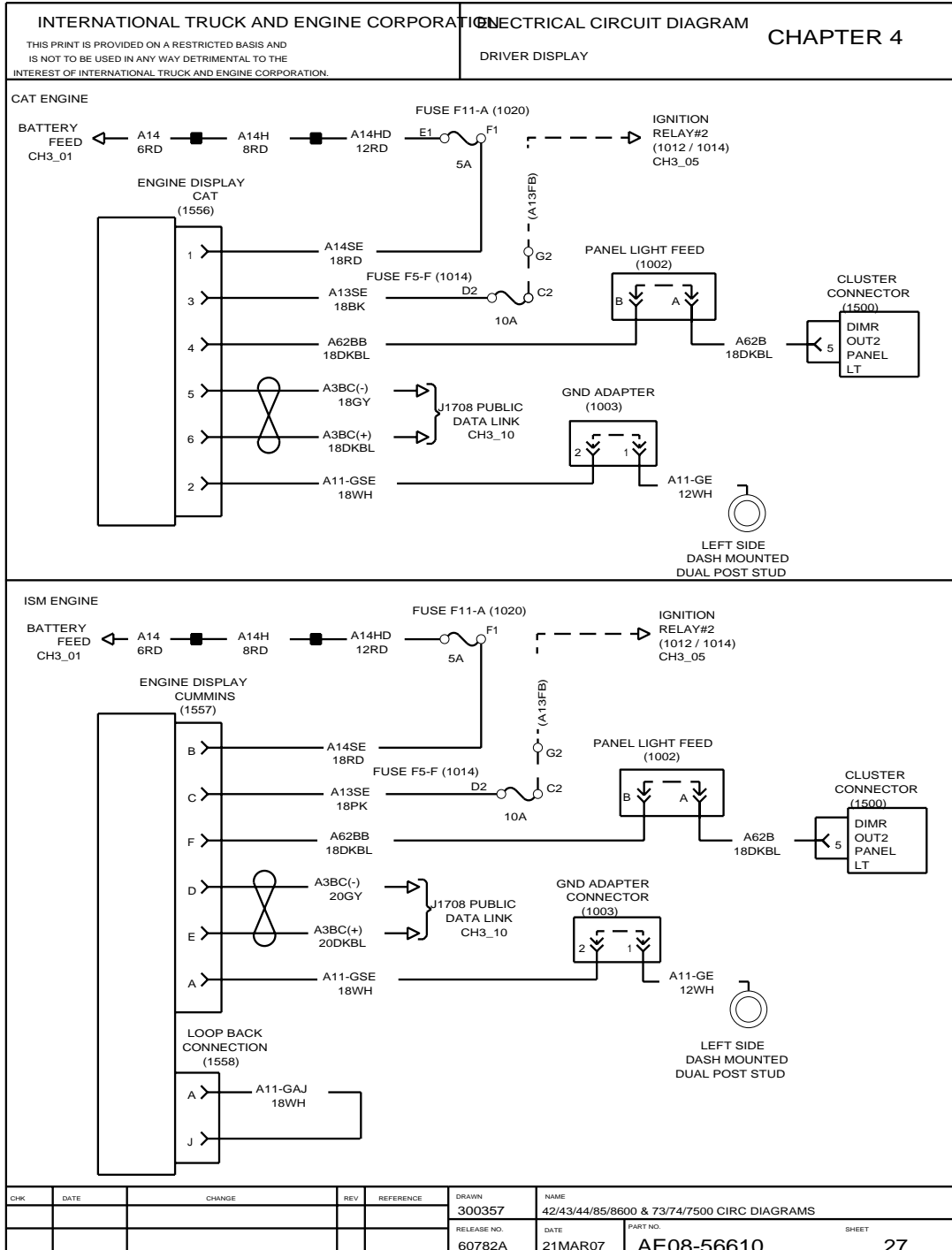

Figure 71 Driver Display

4.30. BACK-UP CAMERA, P. 28

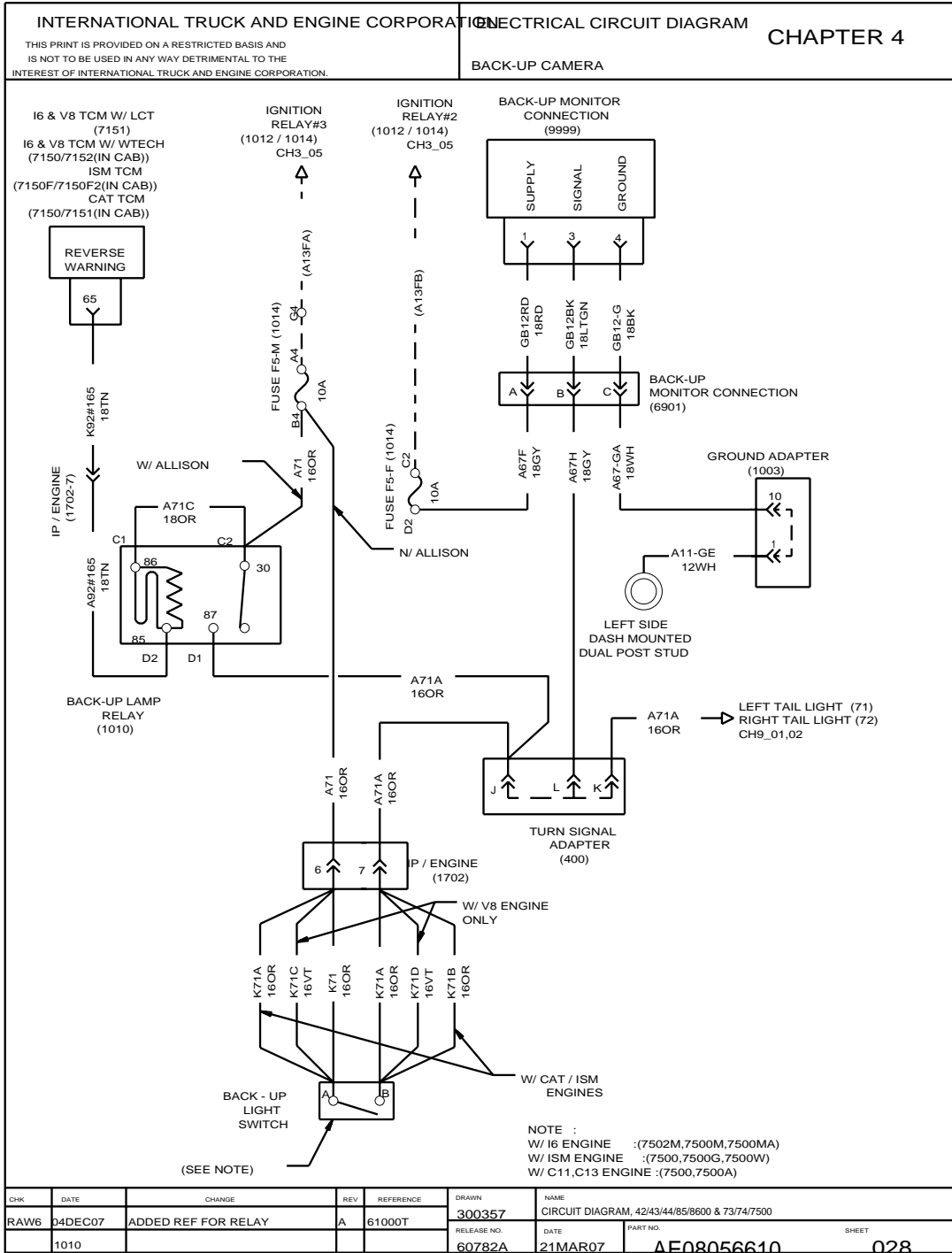

Figure 72 Back-Up Camera

4.31. SATELLITE COMMUNICATION — QUALCOMM MCT, P. 29

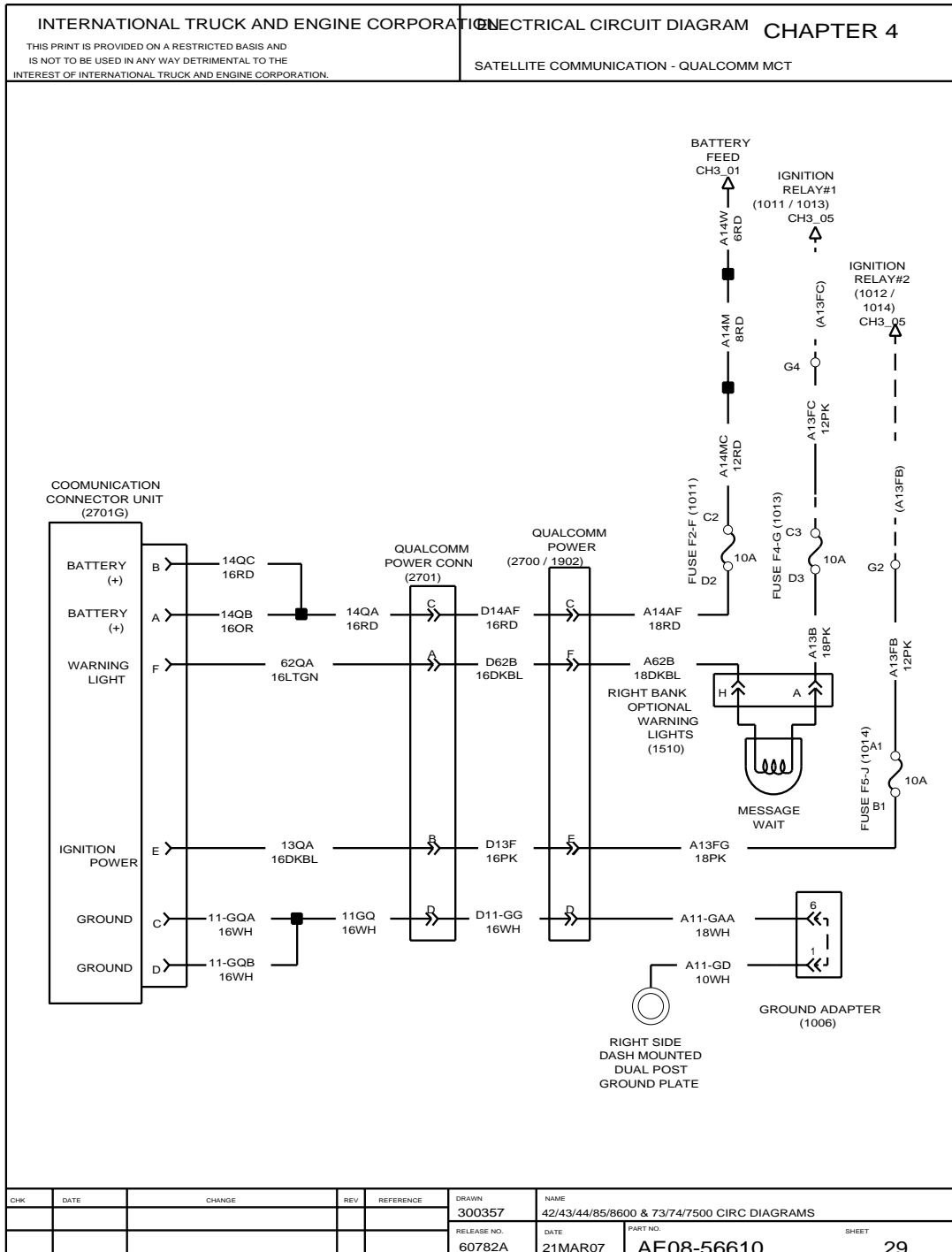

Figure 73 Satellite Communication — Qualcomm MCT

**4.32. SATELLITE COMMUNICATION — QUALCOMM MCT WITH MVPC KEYBOARD,
 P. 30**

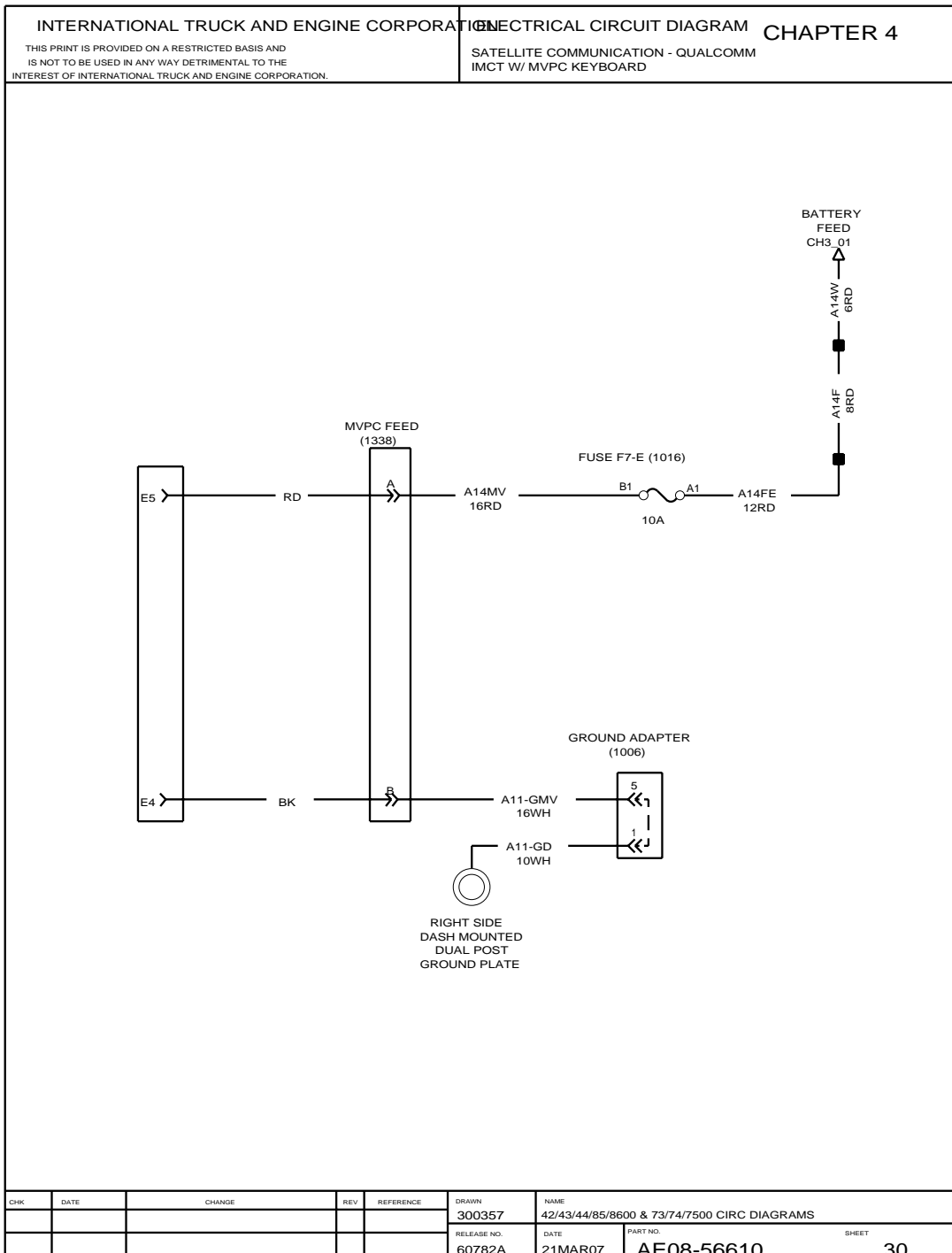

Figure 74 Satellite Communication — Qualcomm MCT with MVPC Keyboard

4.33. SATELLITE COMMUNICATION — QUALCOMM TMCT, P. 31

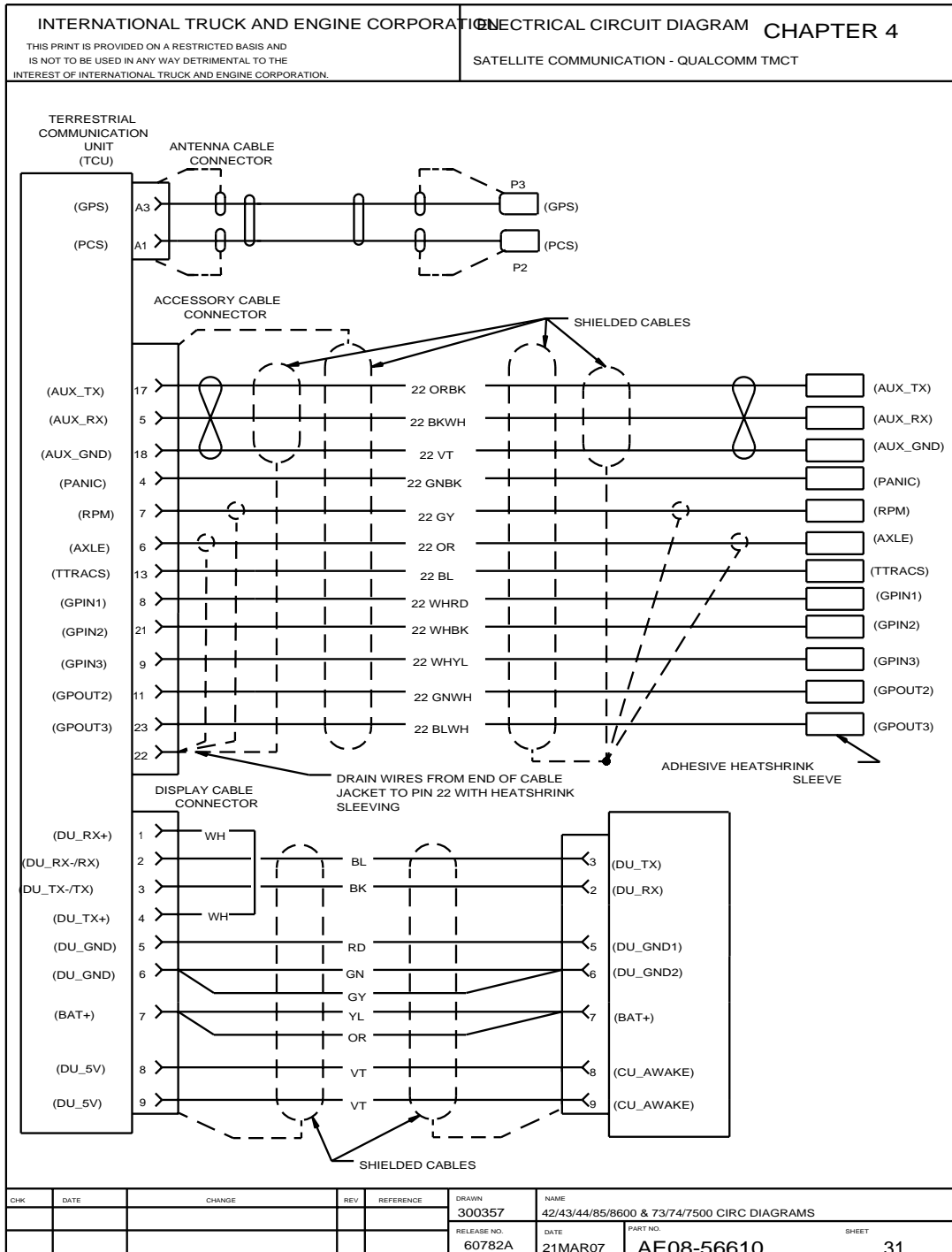

Figure 75 Satellite Communication — Qualcomm TMCT

4.34. SATELLITE COMMUNICATION — QUALCOMM TMCT, P. 32

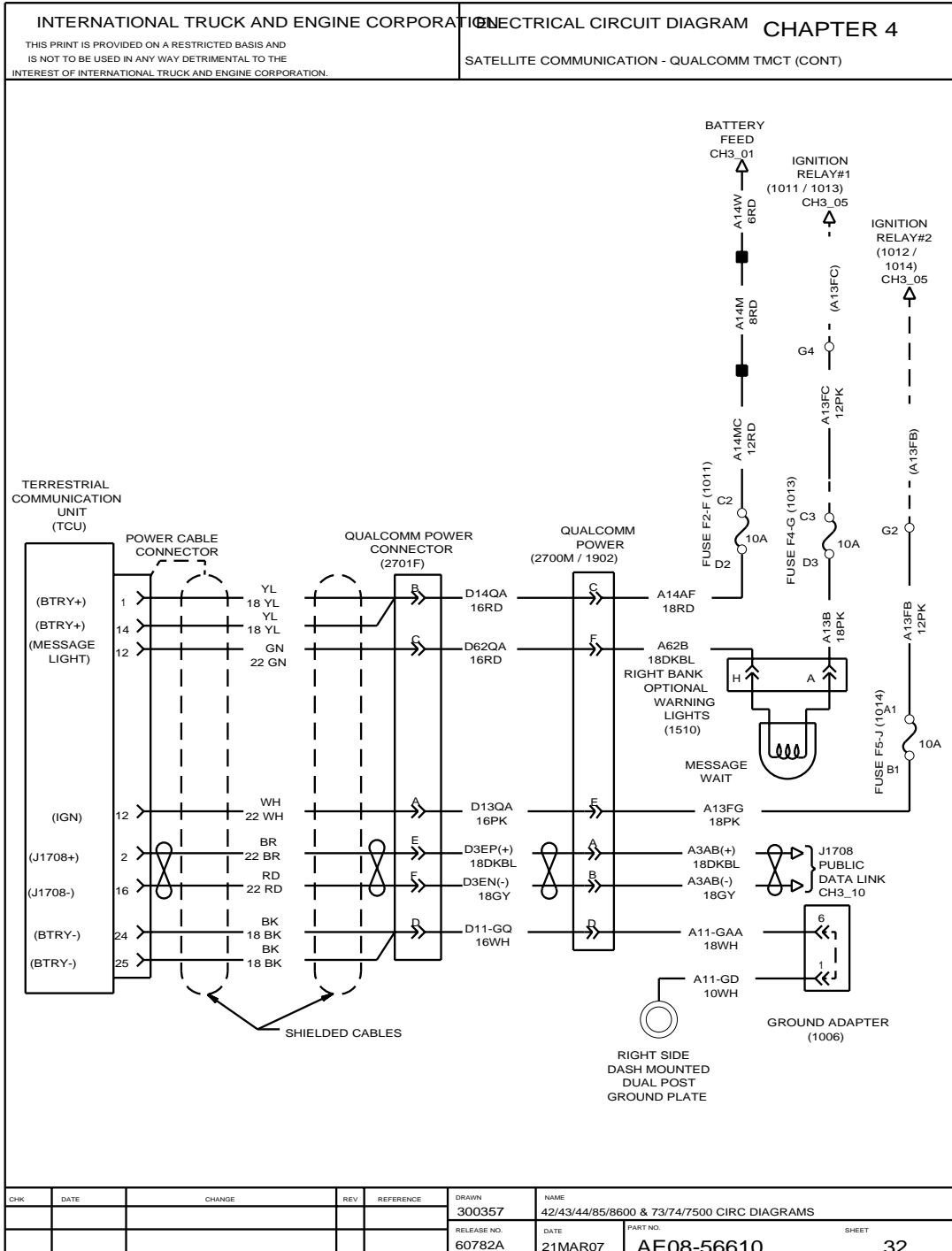

Figure 76 Satellite Communication — Qualcomm TMCT

4.35. AIR SHIELD LIGHT, P. 33

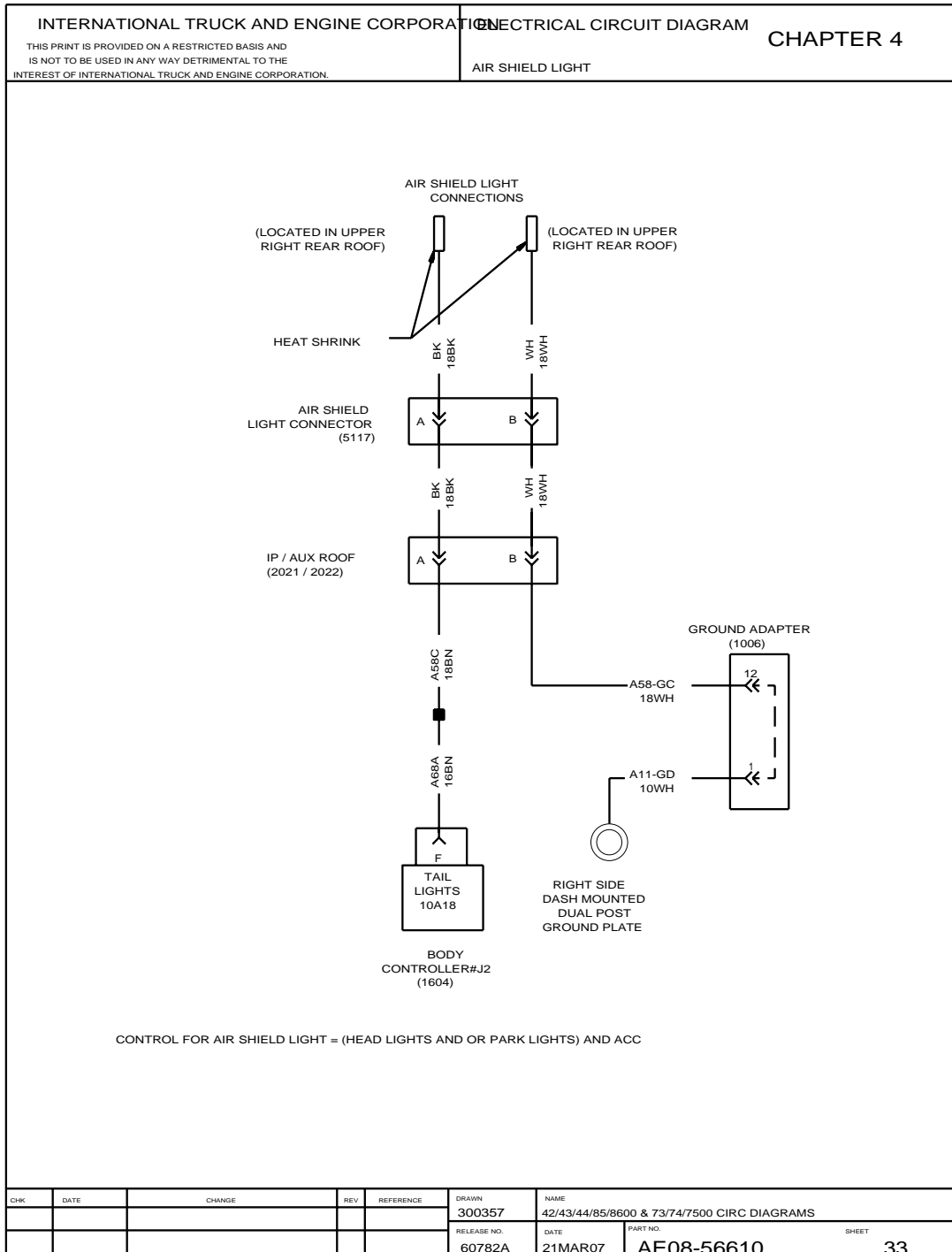

Figure 77 Air Shield Light

5. 12V CHARGING + CRANKING SYSTEM (CHAPTER 5)

5.1. I6 / V8 ENGINES WITH MANUAL TRANSMISSION, P. 1

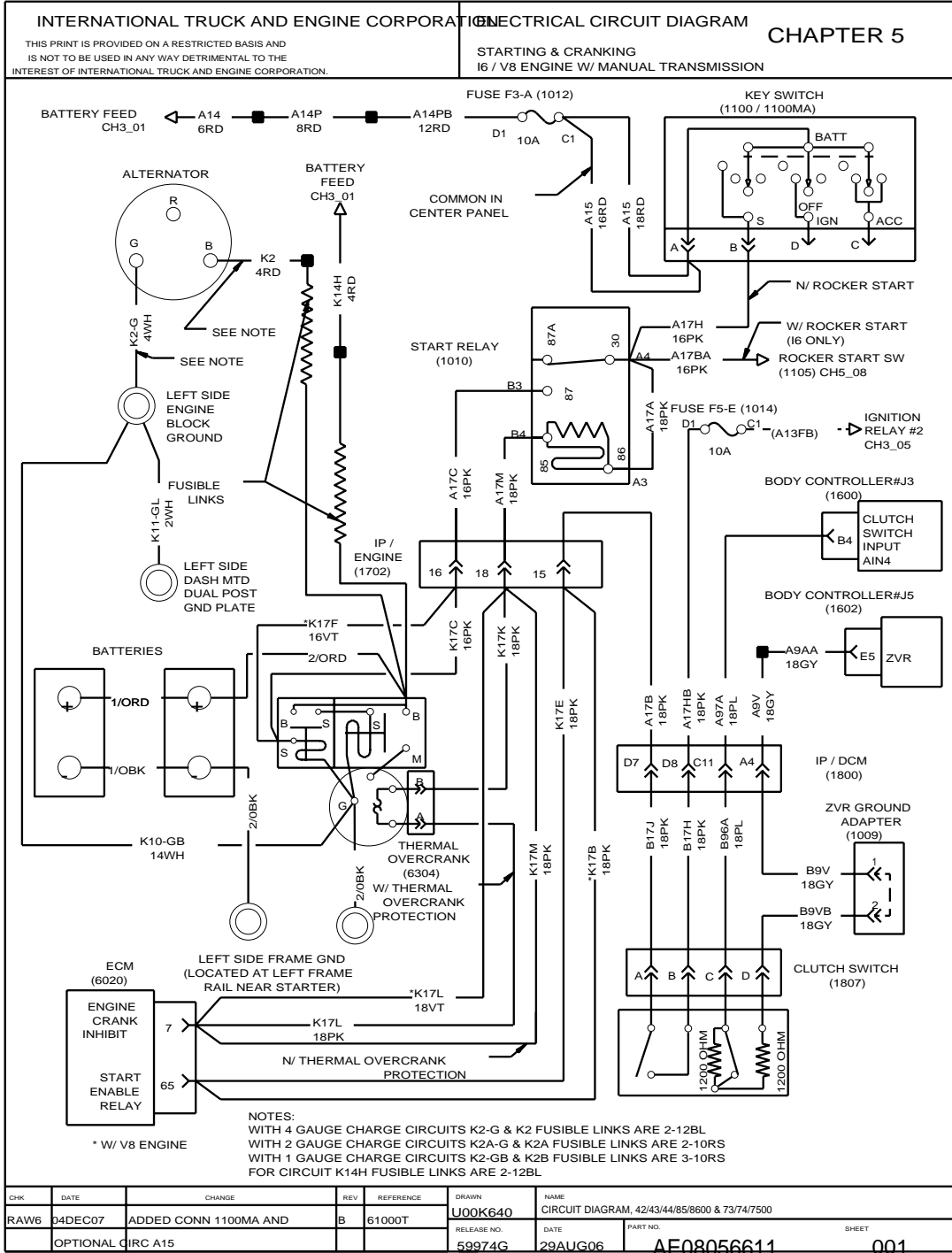

Figure 78 I6 / V8 Engines with Manual Transmission

5.2. CAT — CUMMINS ENGINES WITH MANUAL TRANSMISSION, P. 2

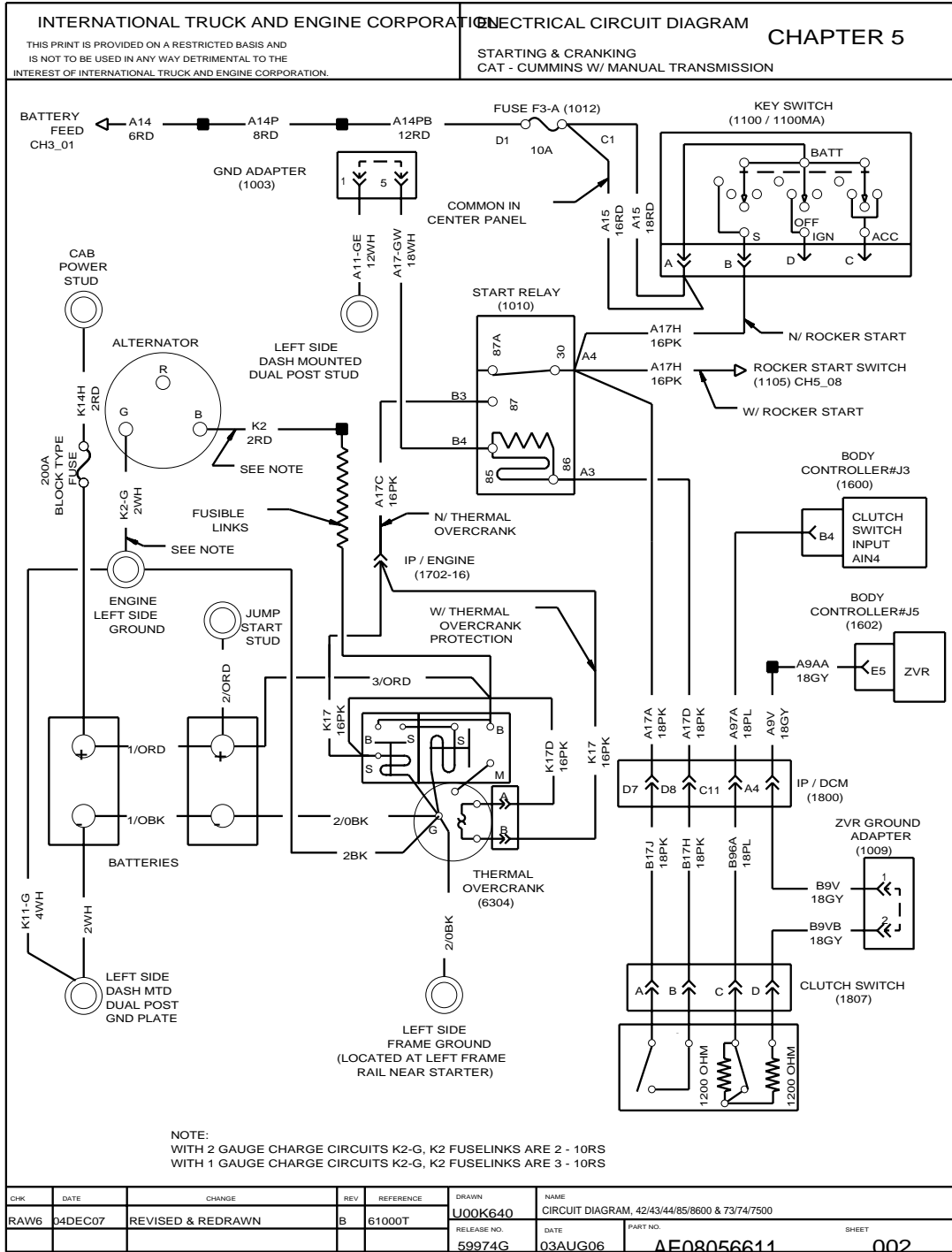

Figure 79 Cat — Cummins Engines with Manual Transmission

5.3. I6 / V8 ENGINES WITH ALLISON TRANSMISSION, P. 3

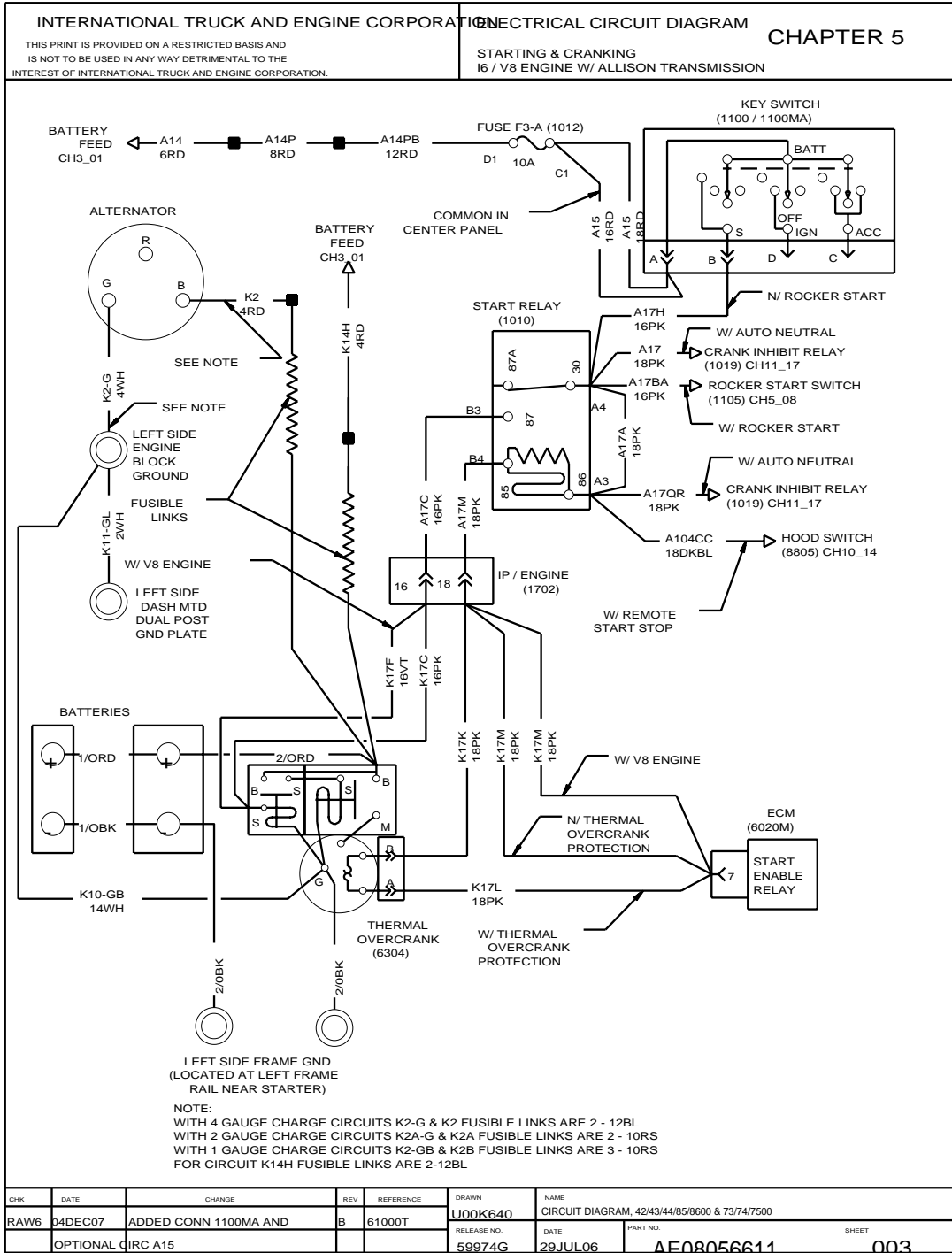

Figure 80 I6 / V8 Engines with Allison Transmission

5.4. CAT — CUMMINS ENGINES WITH ALLISON TRANSMISSION, P. 4

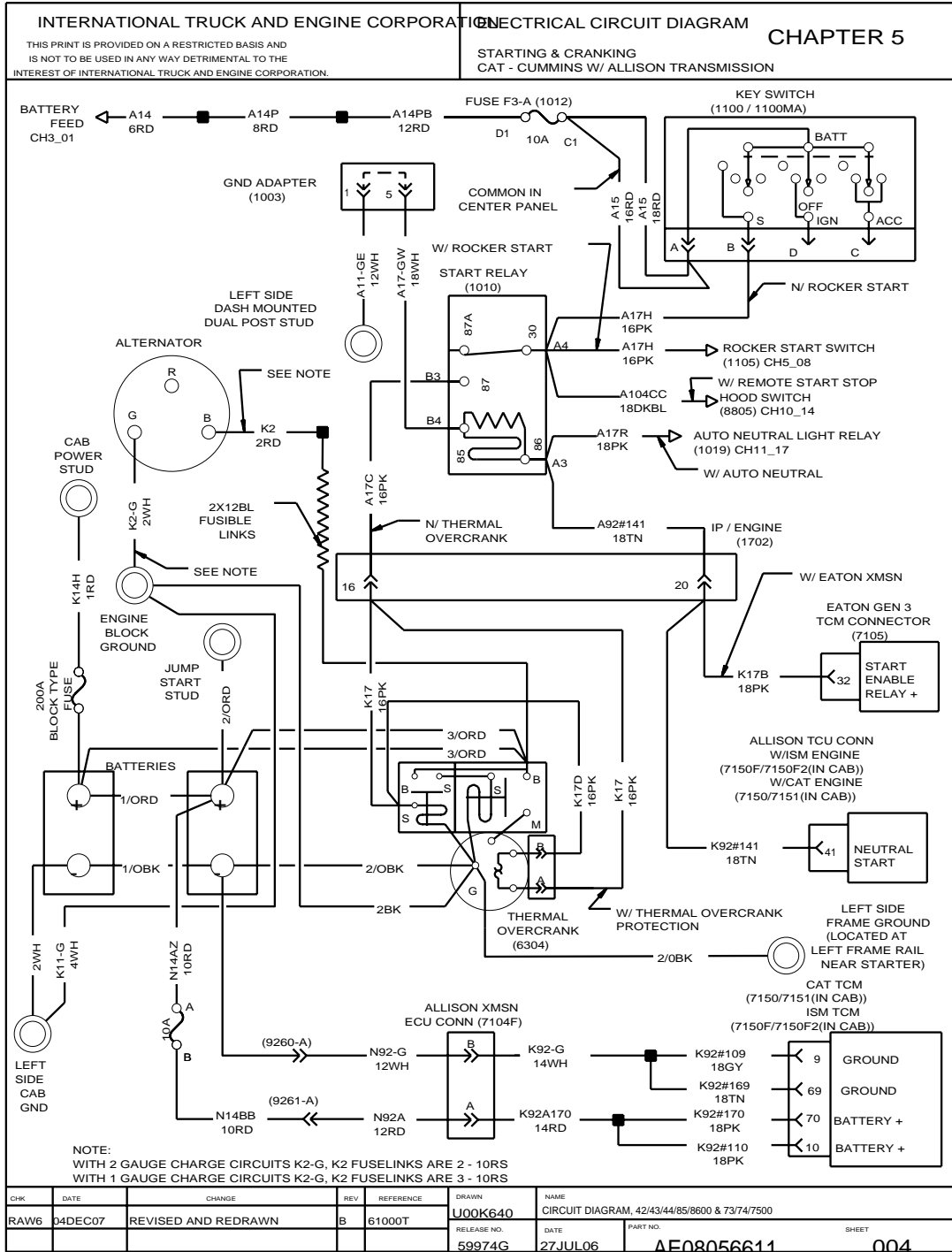

Figure 81 Cat — Cummins Engines with Allison Transmission

5.5. I6 ENGINE WITH AUTOSHIFT, ULTRASHIFT AND EATON HYBRID TRANSMISSION, P. 5

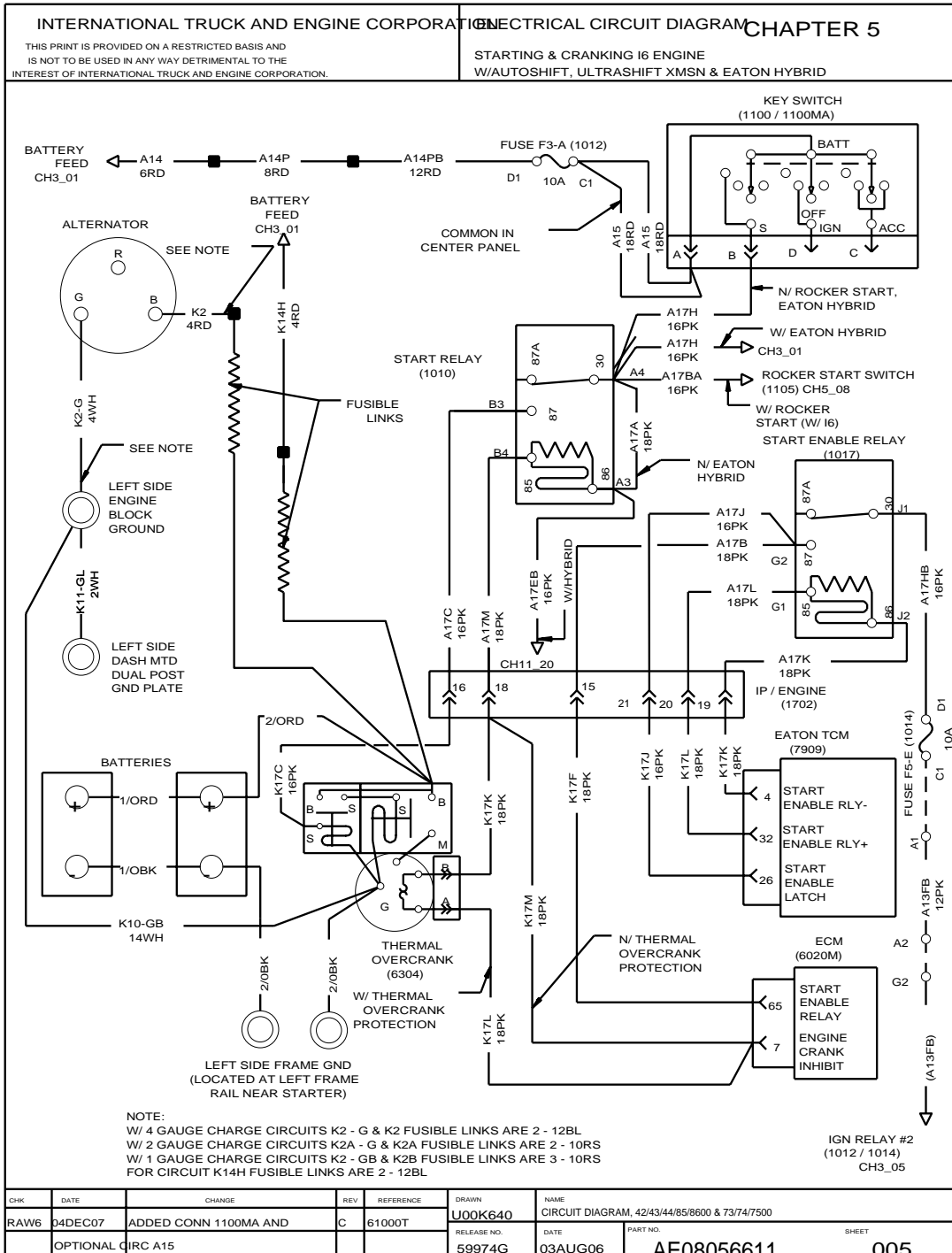

Figure 82 I6 Engine with Autoshift, Ultrashift, and Eaton Hybrid Transmission

5.6. CAT — CUMMINS ENGINES WITH AUTOSHIFT AND ULTRASHIFT TRANSMISSION,
 P. 6

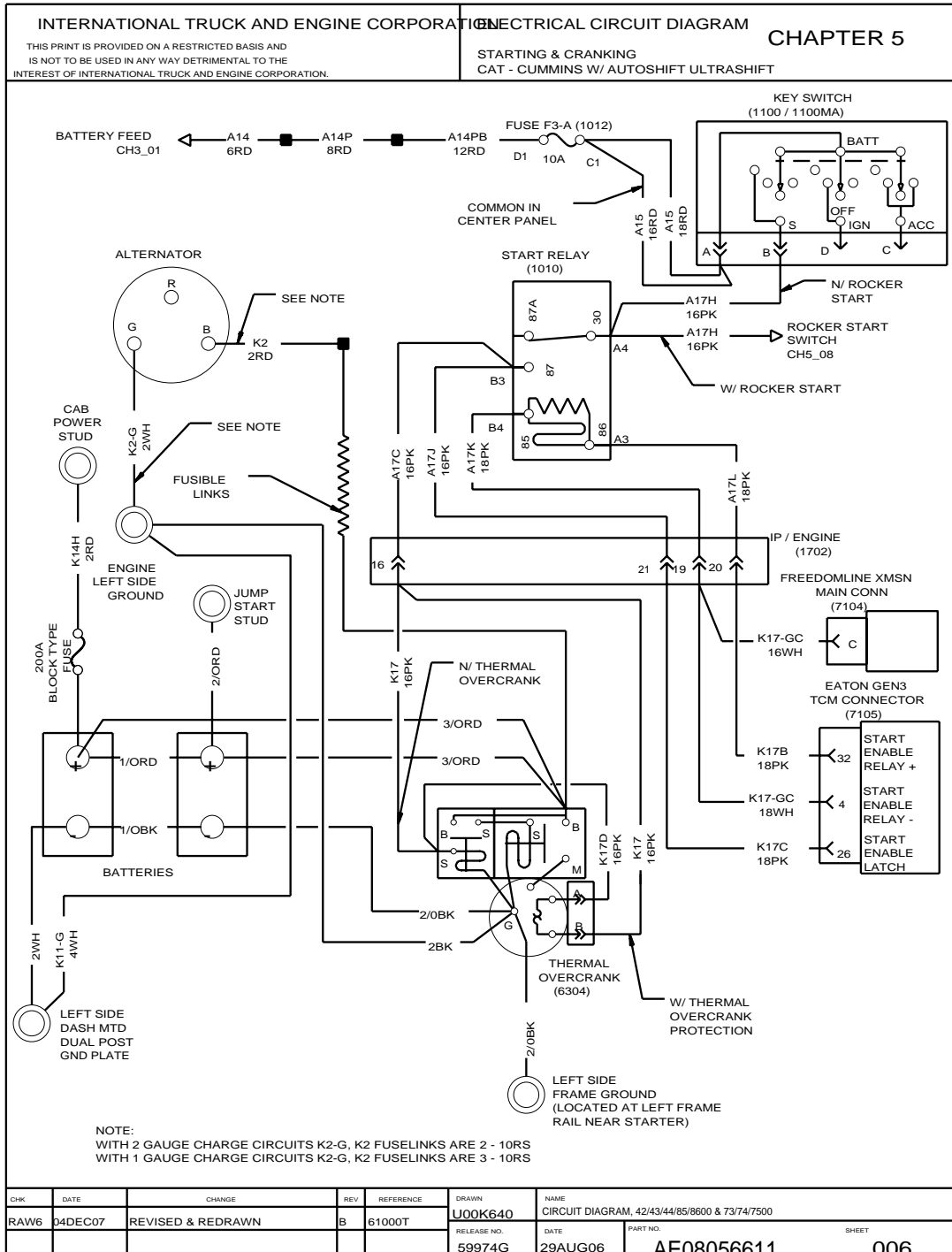

Figure 83 Cat — Cummins Engines with Autoshift and Ultrashift Transmission

5.7. I6 POWER PACK, P. 7

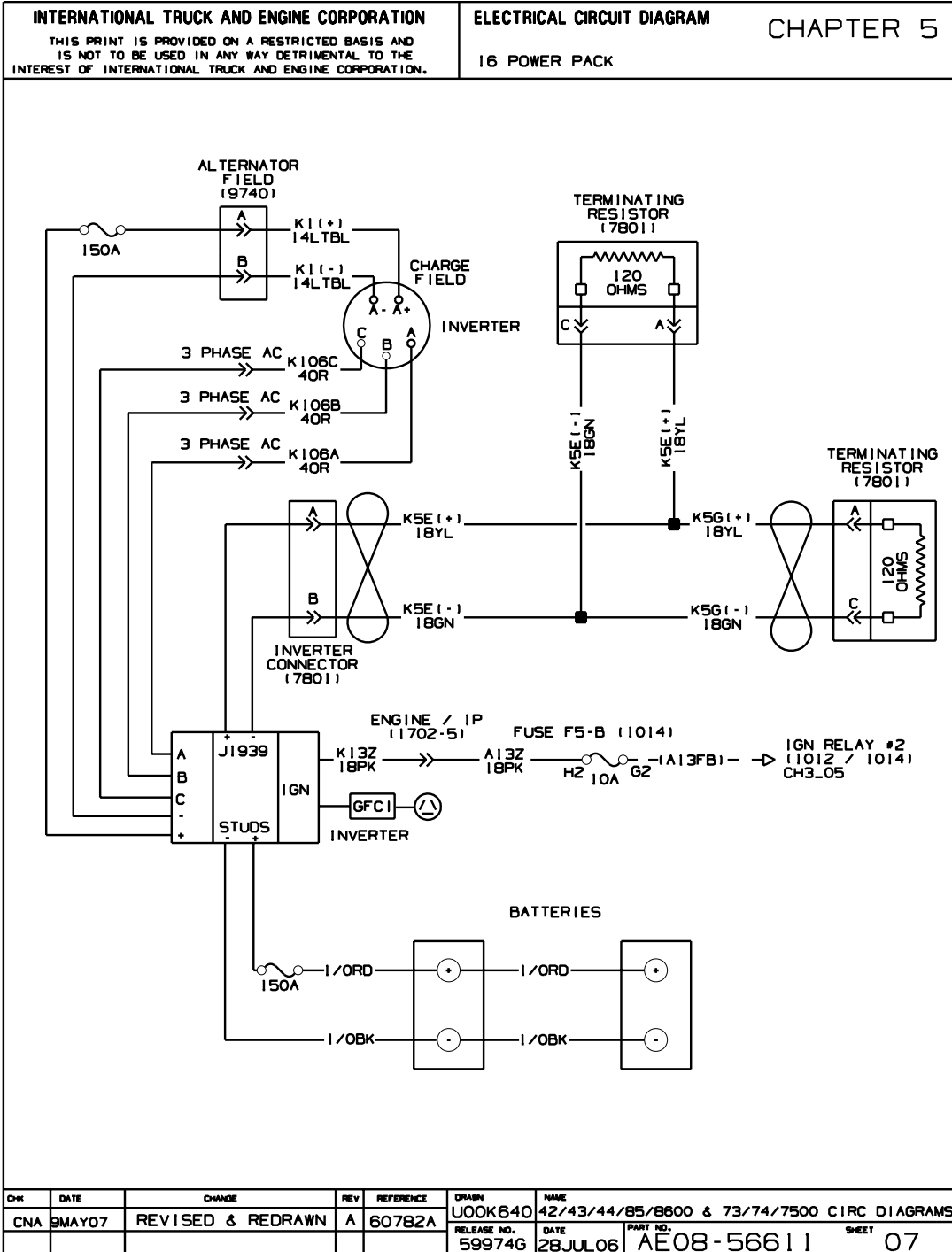

Figure 84 I6 Power Pack

5.8. ROCKER START, P. 8

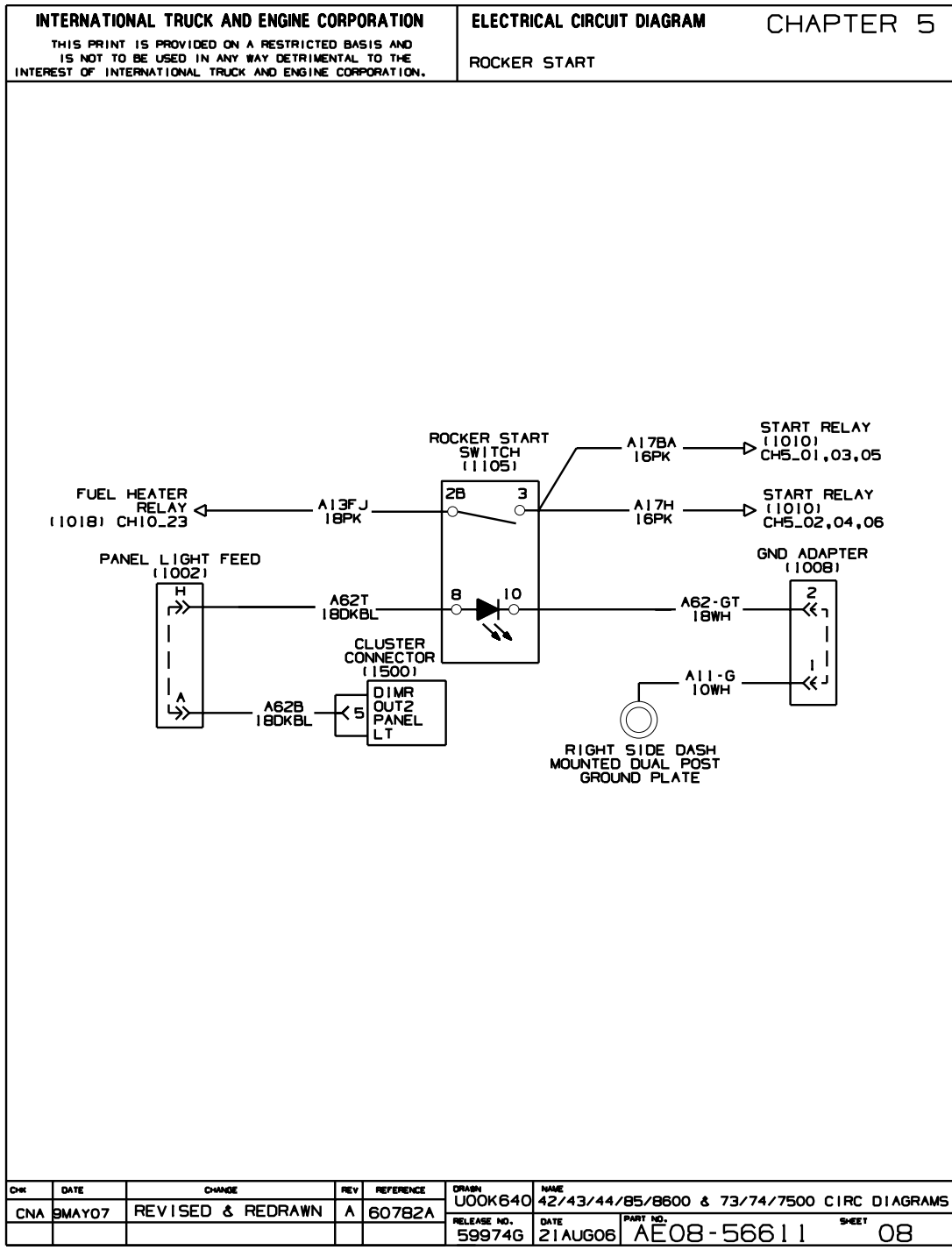

Figure 85 Rocker Start

6. FANS AND ENGINE ACCESSORIES (CHAPTER 6)

6.1. FAN WIRING, I6 / V8 2007 ENGINES, P. 1

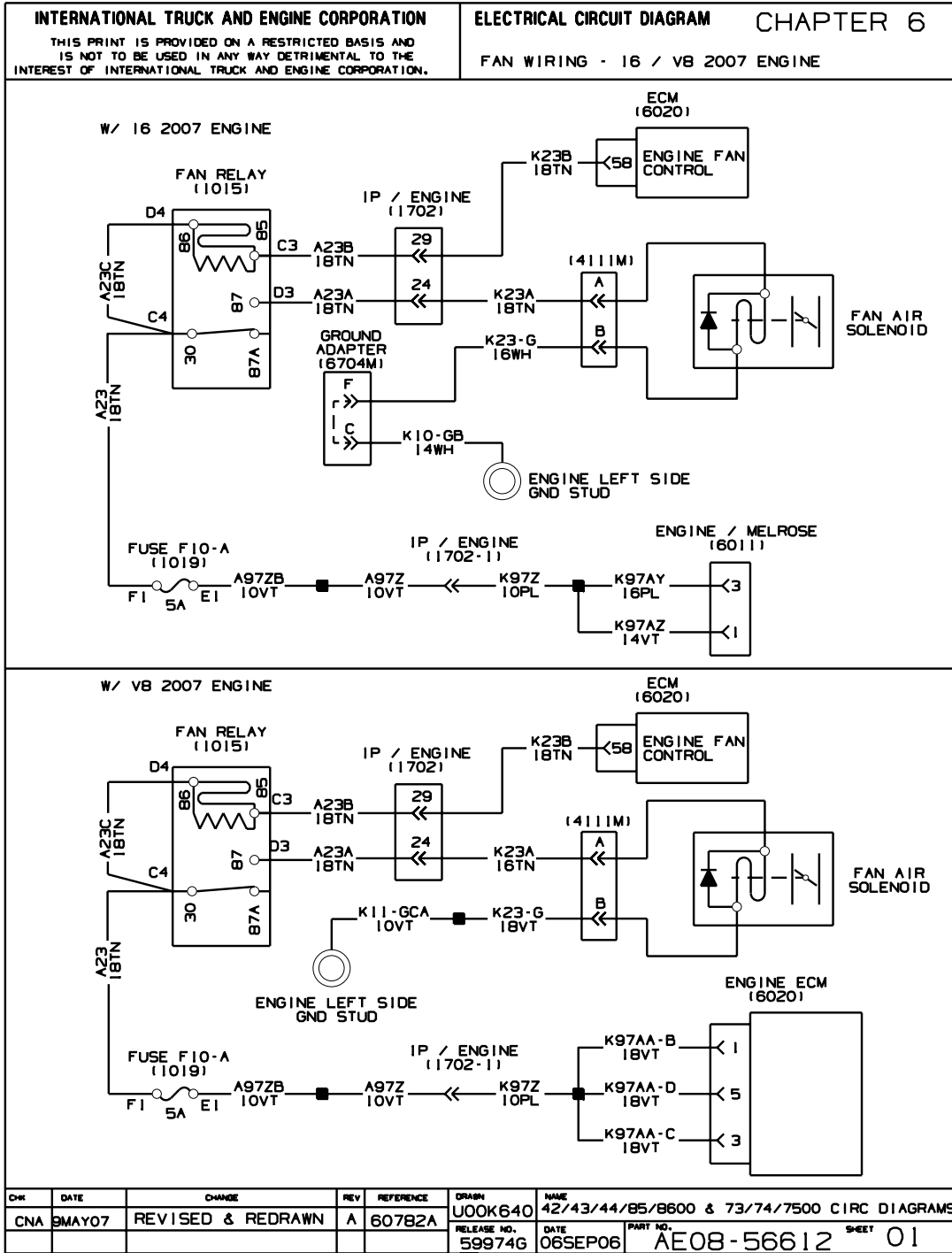

Figure 86 Fan Wiring, I6 / V8 2007 Engines

6.2. FAN WIRING, ISM, C11-C13 2007 ENGINES, P. 2

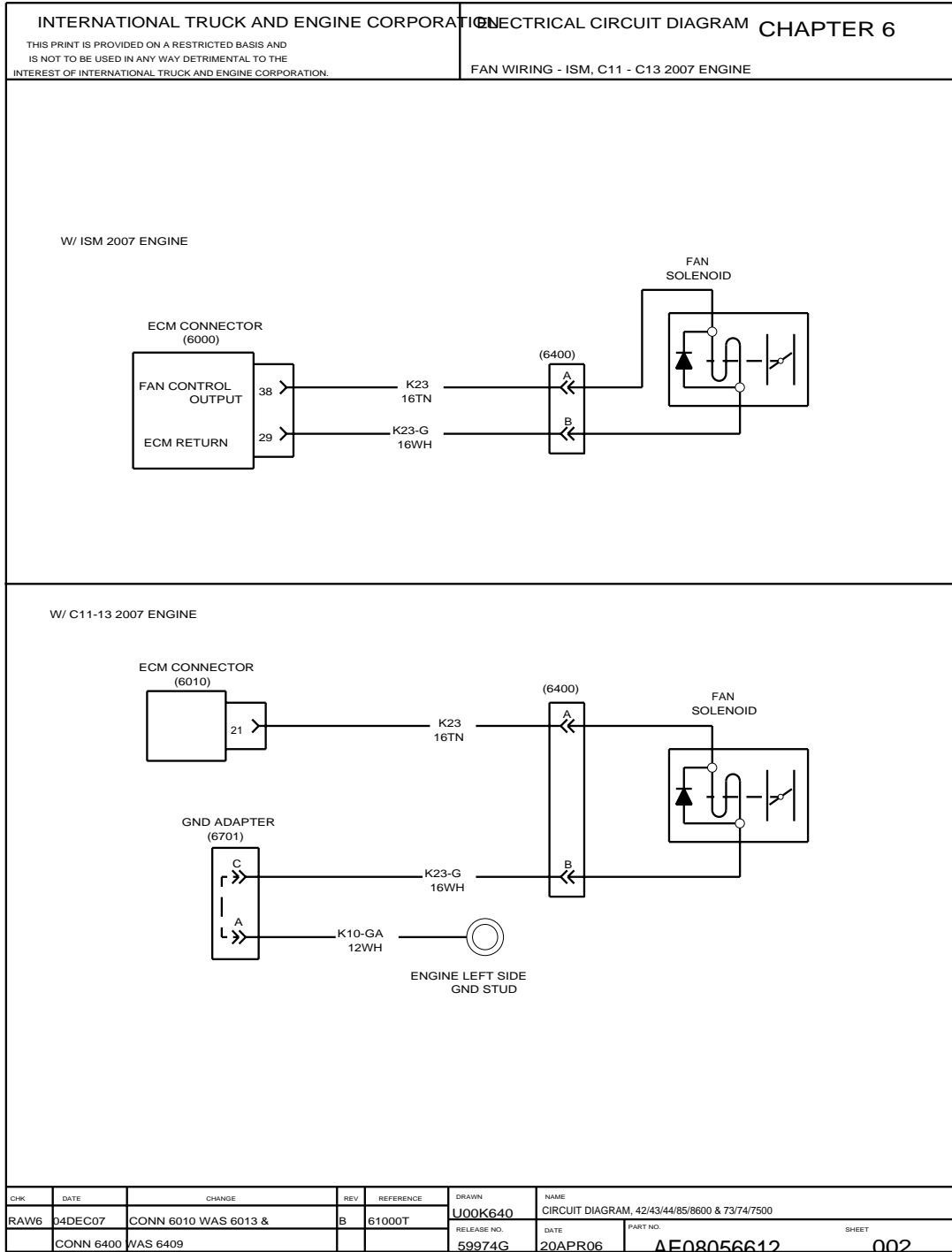

Figure 87 Fan Wiring, ISM, C11-C13 2007 Engines

6.3. STARTING AID — ETHER START, P. 3

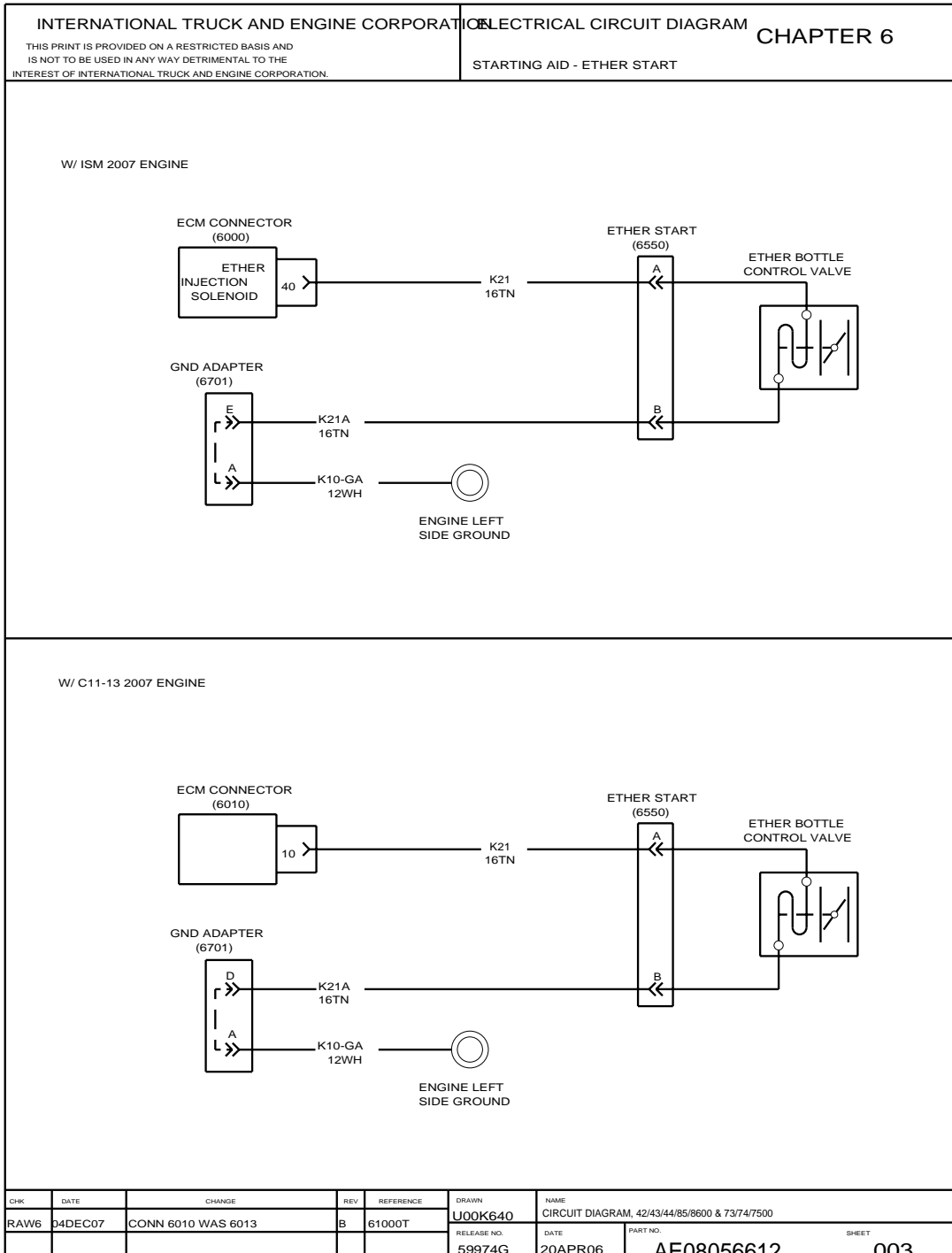

Figure 88 Starting Aid — Ether Start

6.4. SNOW VALVE, P. 4

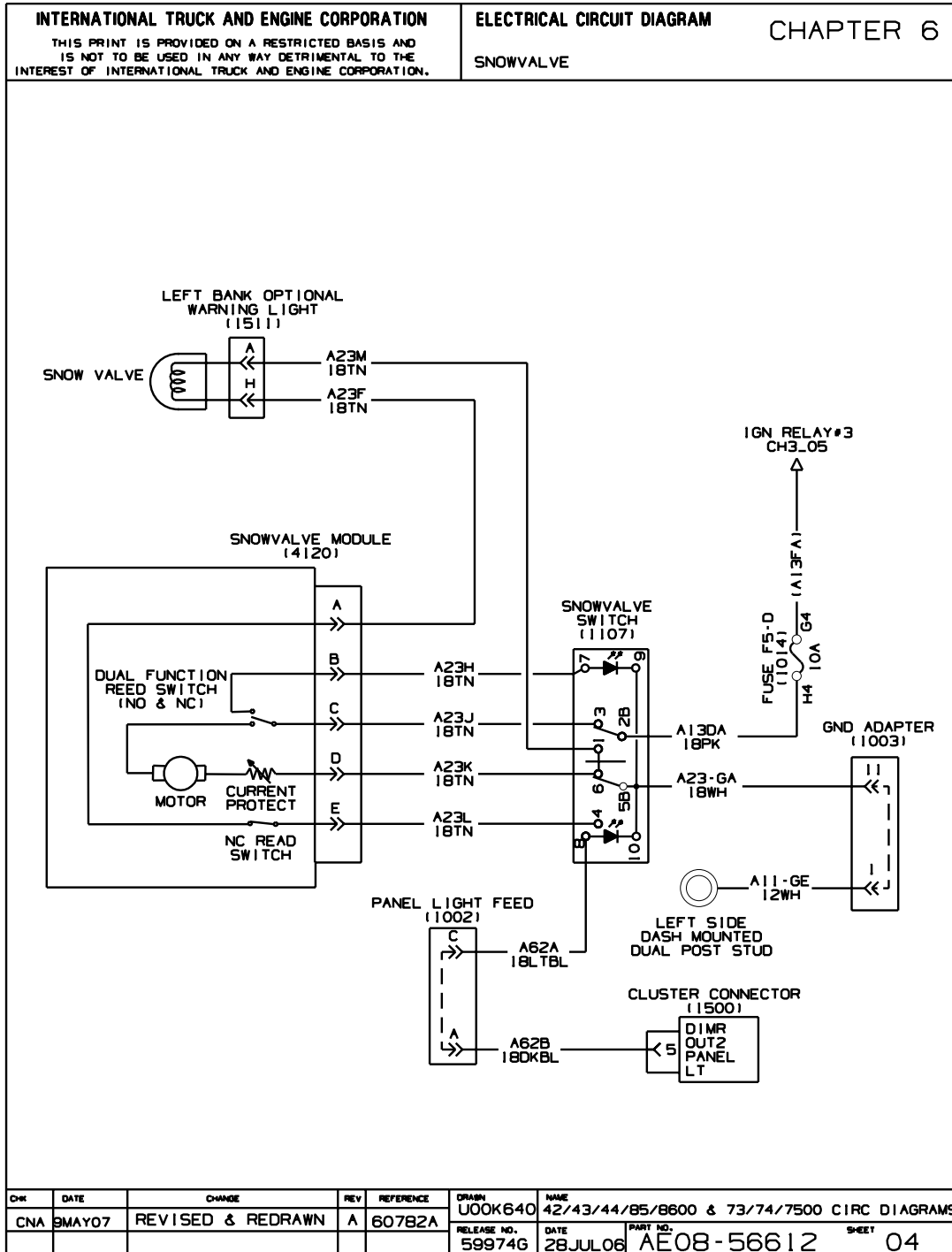

Figure 89 Snow Valve

7. ELECTRONIC ENGINES (CHAPTER 7)

7.1. ELECTRONIC ENGINE CONTROLS, CAT ENGINES, P. 1

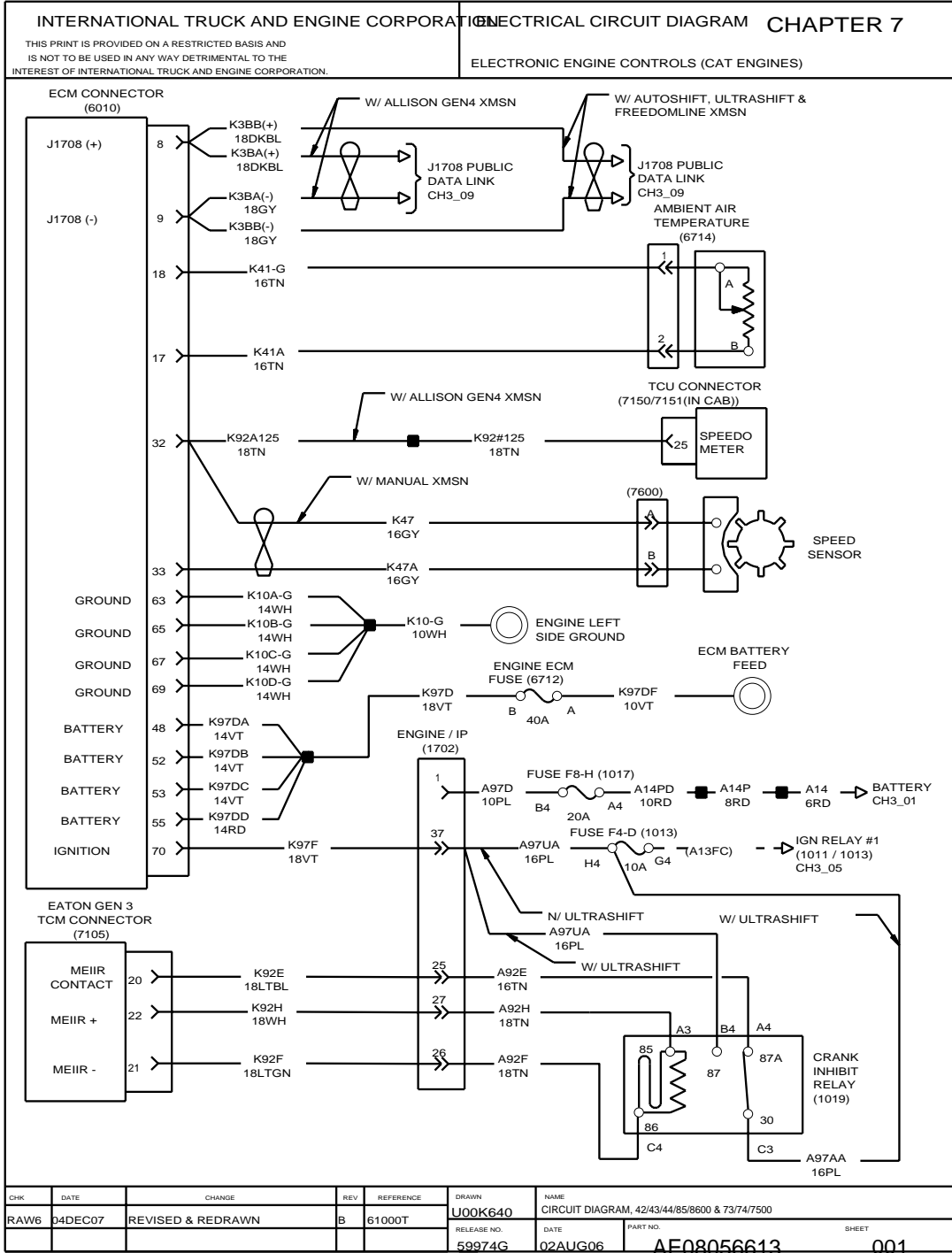

Figure 90 Electronic Engine Controls, Cat Engines

7.2. ELECTRONIC ENGINE CONTROLS, CAT ENGINES, P. 2

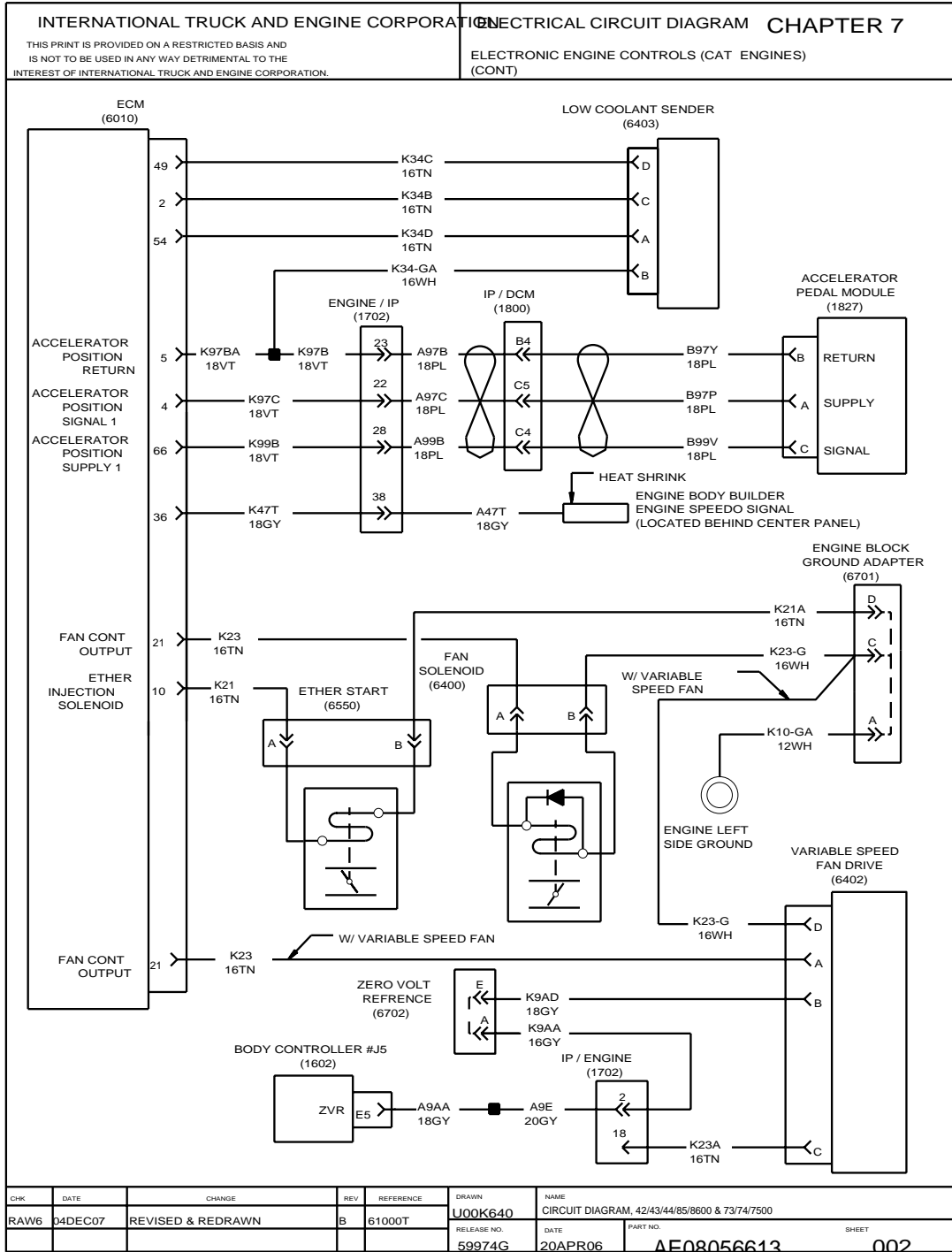

Figure 91 Electronic Engine Controls, Cat Engines (Cont.)

7.3. ENGINE BODY BUILDER — REMOTE ENGINE CONTROL (CAT/IBBE ENGINE), P. 3

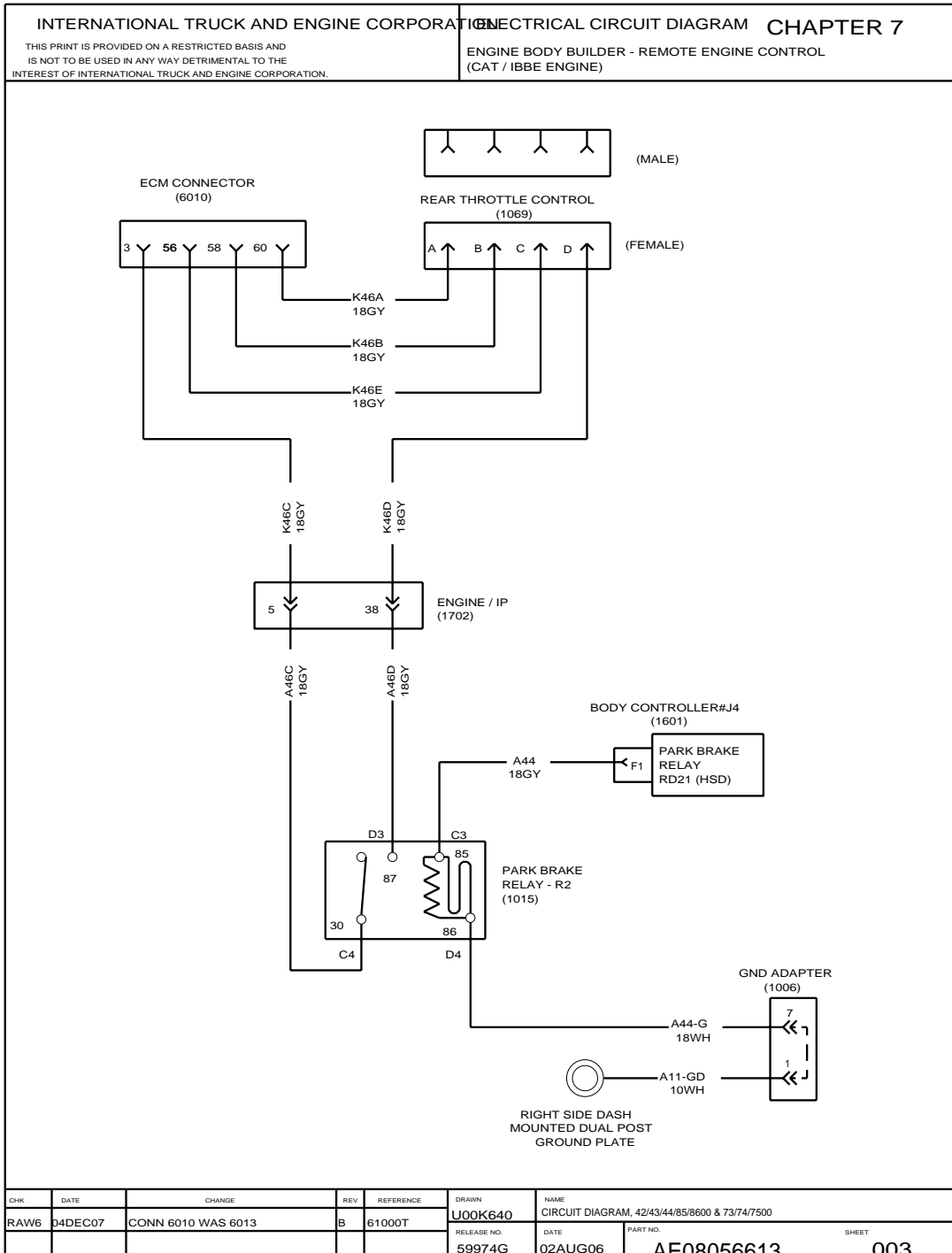

Figure 92 Engine Body Builder — Remote Engine Control (Cat/IBBE Engine)

7.4. ELECTRONIC ENGINE CONTROLS, ISM ENGINES, P. 4

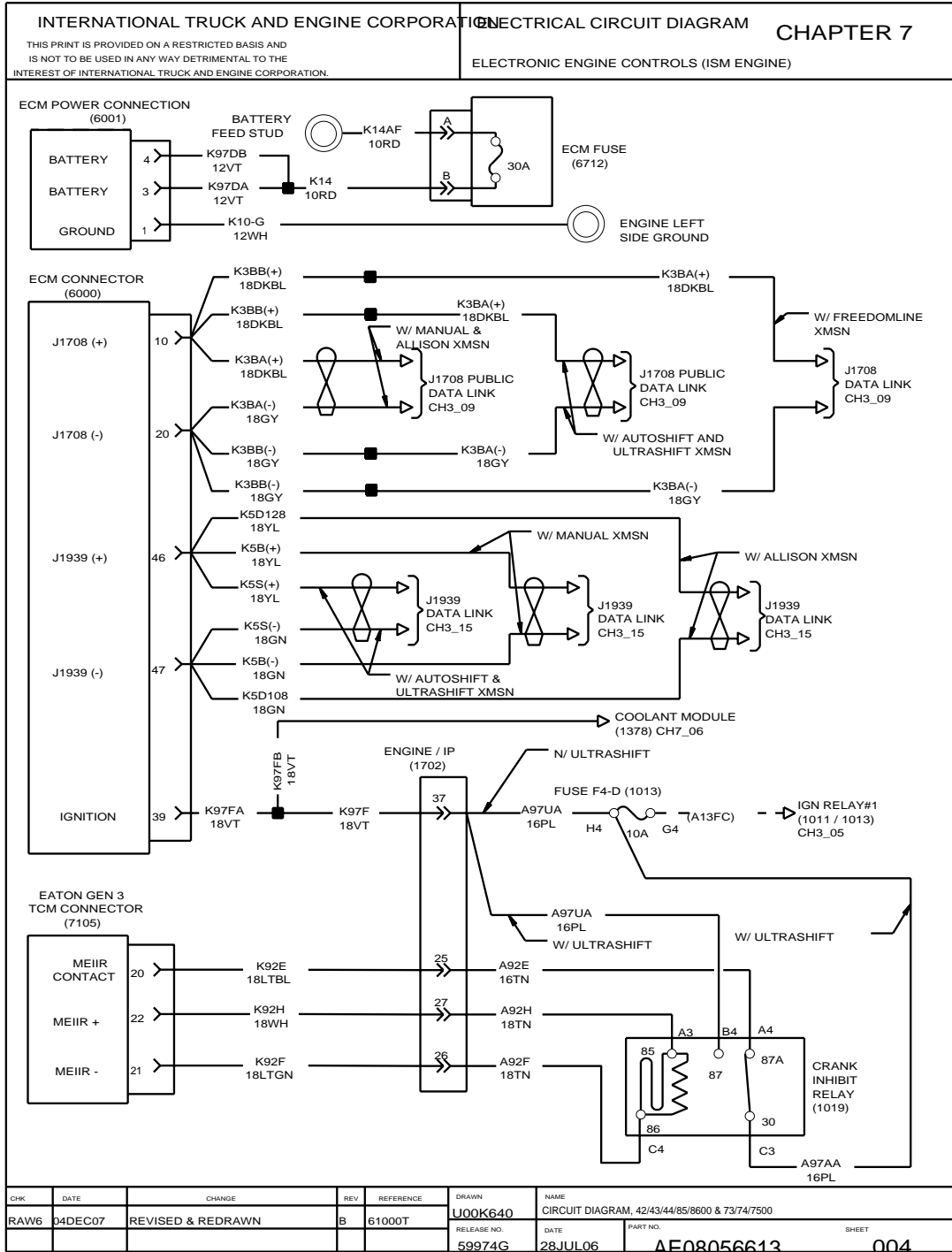

Figure 93 Electronic Engine Controls, ISM Engines

7.5. ELECTRONIC ENGINE CONTROLS, ISM ENGINES, P. 5

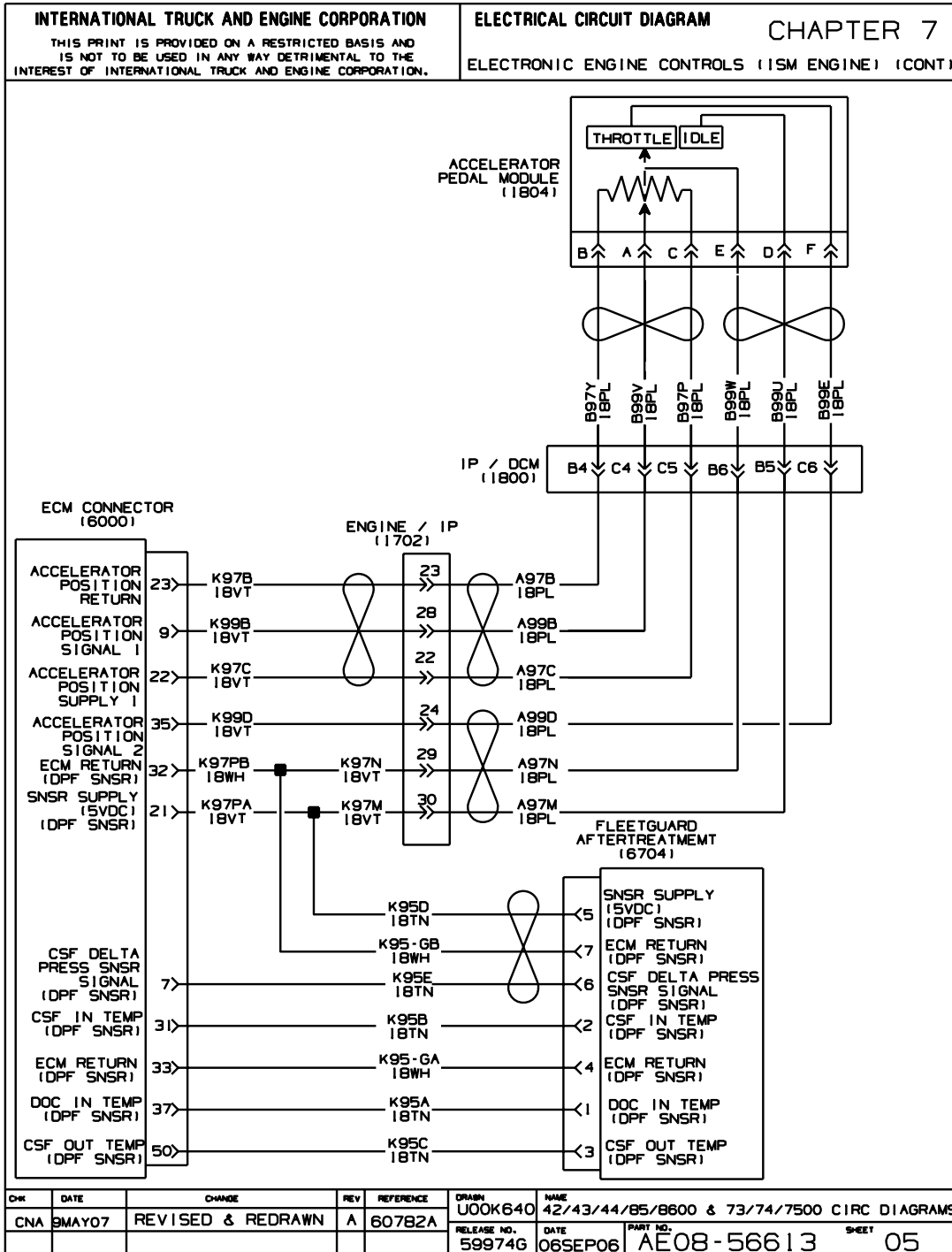

Figure 94 Electronic Engine Controls, ISM Engines (Cont.)

7.6. ELECTRONIC ENGINE CONTROLS, ISM ENGINES, P. 6

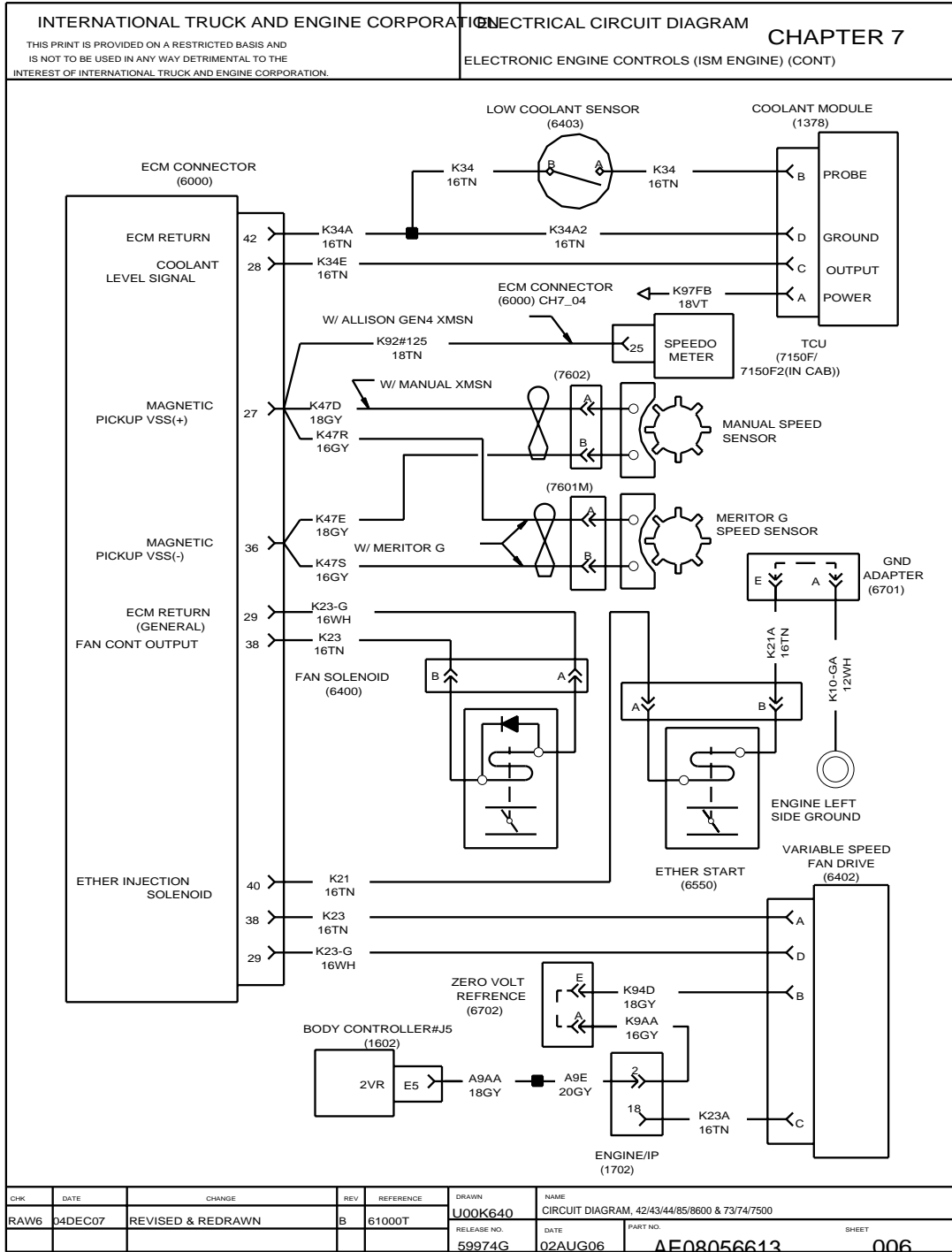

Figure 95 Electronic Engine Controls, ISM Engines (Cont.)

7.7. ELECTRONIC ENGINE CONTROLS, I6 ENGINES, P. 7

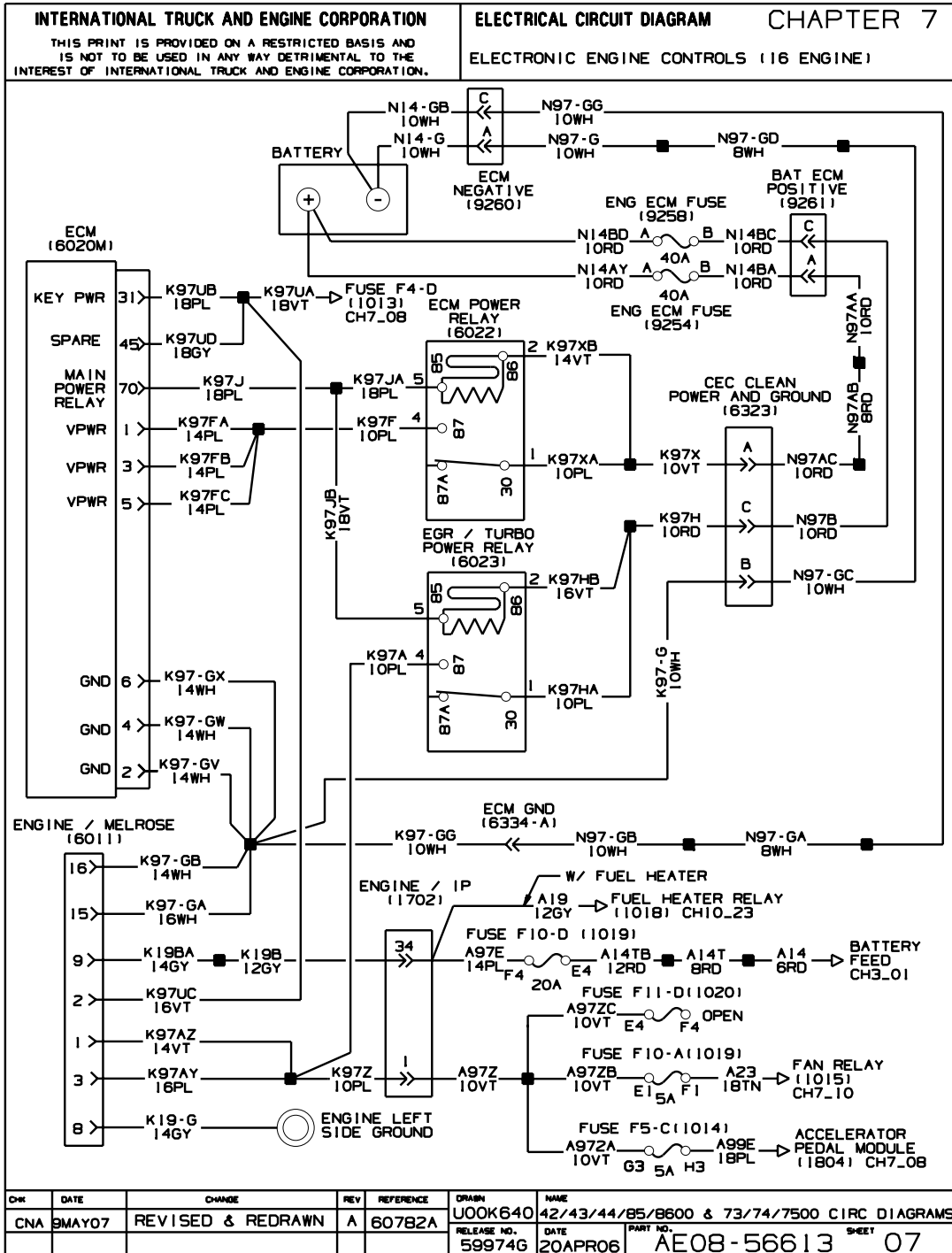

Figure 96 Electronic Engine Controls, I6 Engines

7.8. ELECTRONIC ENGINE CONTROLS, I6 ENGINES, P. 8

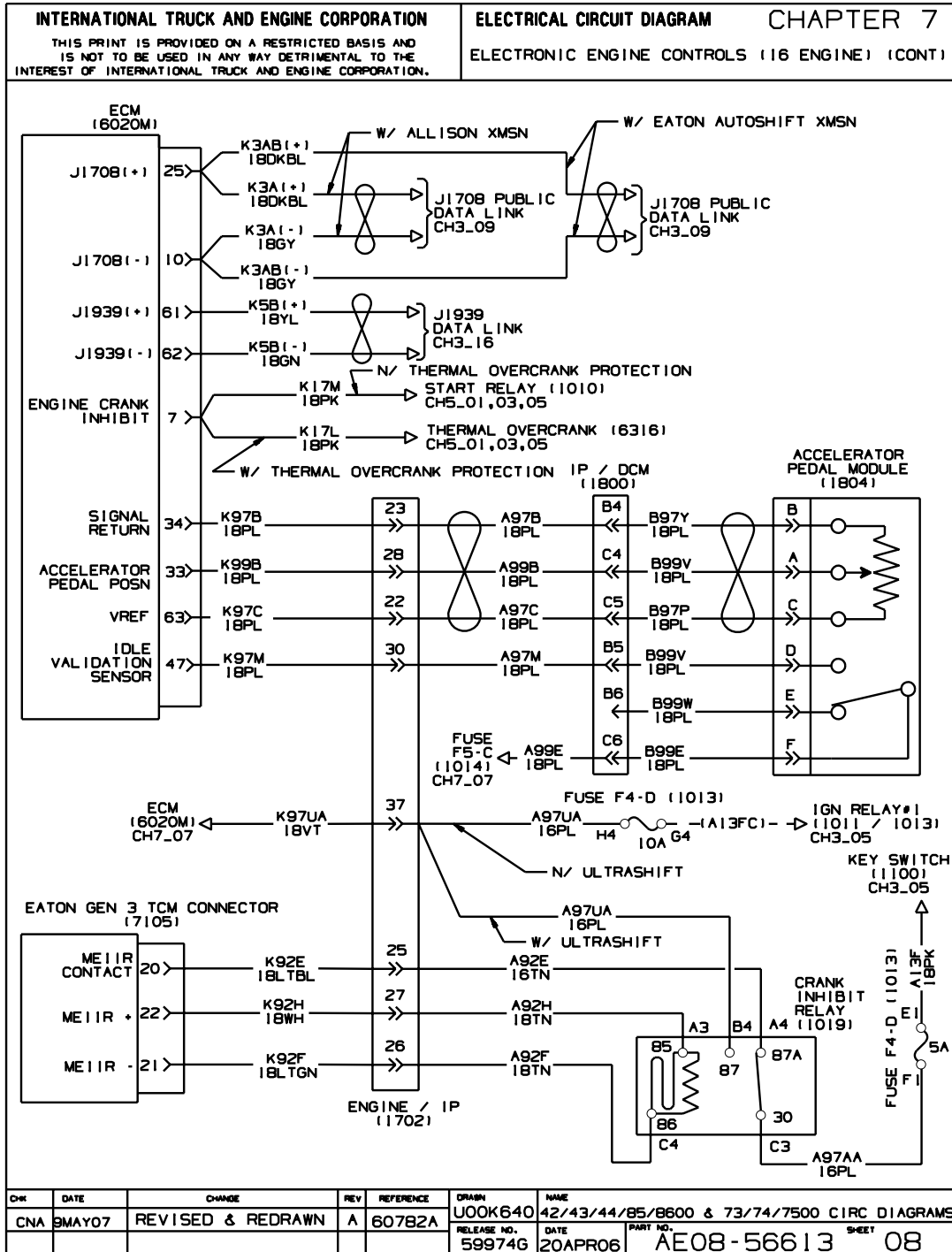

Figure 97 Electronic Engine Controls, I6 Engines (Cont.)

7.9. ELECTRONIC ENGINE CONTROLS, I6 ENGINES, P. 9

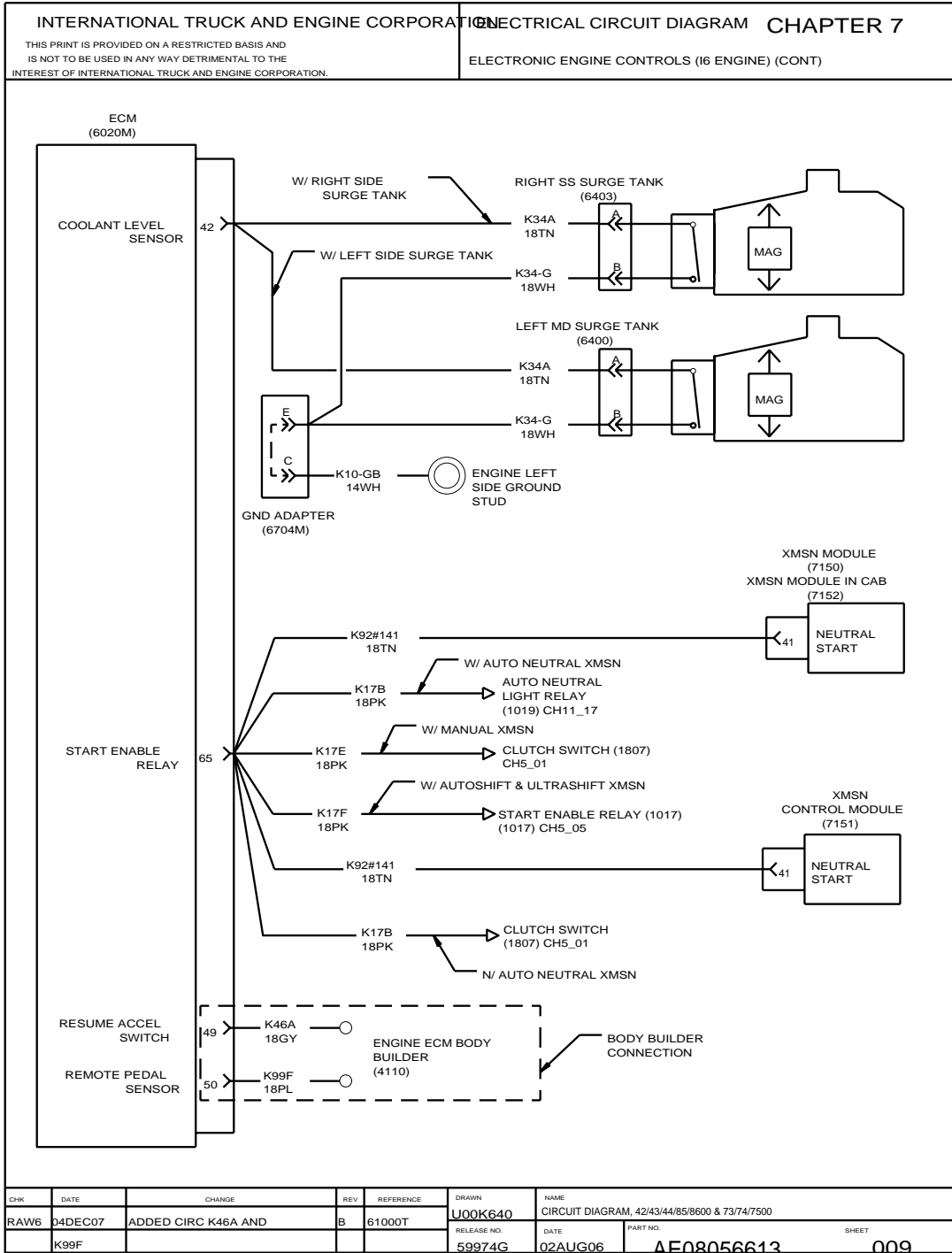

Figure 98 Electronic Engine Controls, I6 Engines (Cont.)

7.10. ELECTRONIC ENGINE CONTROLS, I6 ENGINES, P. 10

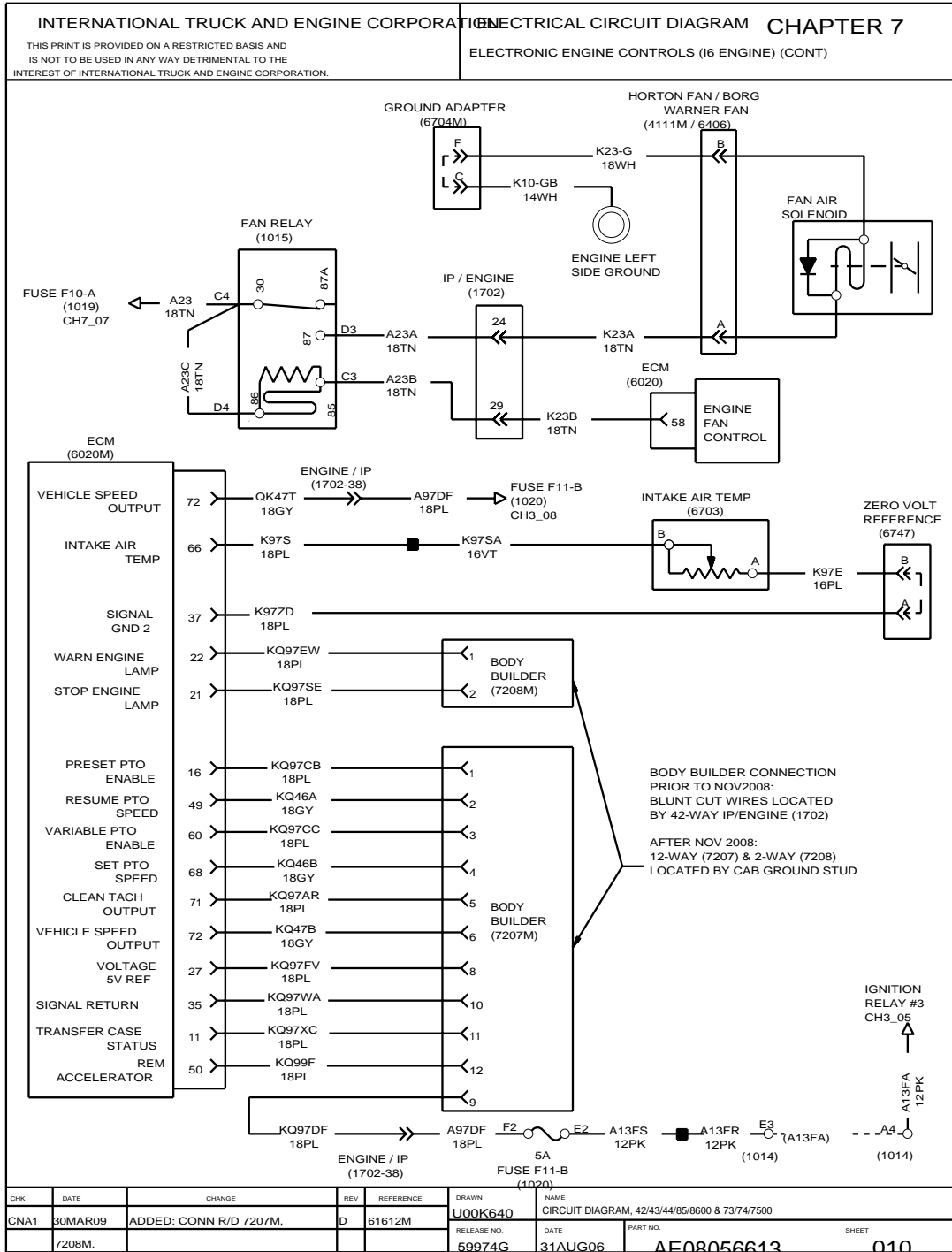

Figure 99 Electronic Engine Controls, I6 Engines (Cont.)

7.11. ELECTRONIC ENGINE CONTROLS, I6 ENGINES, P. 11

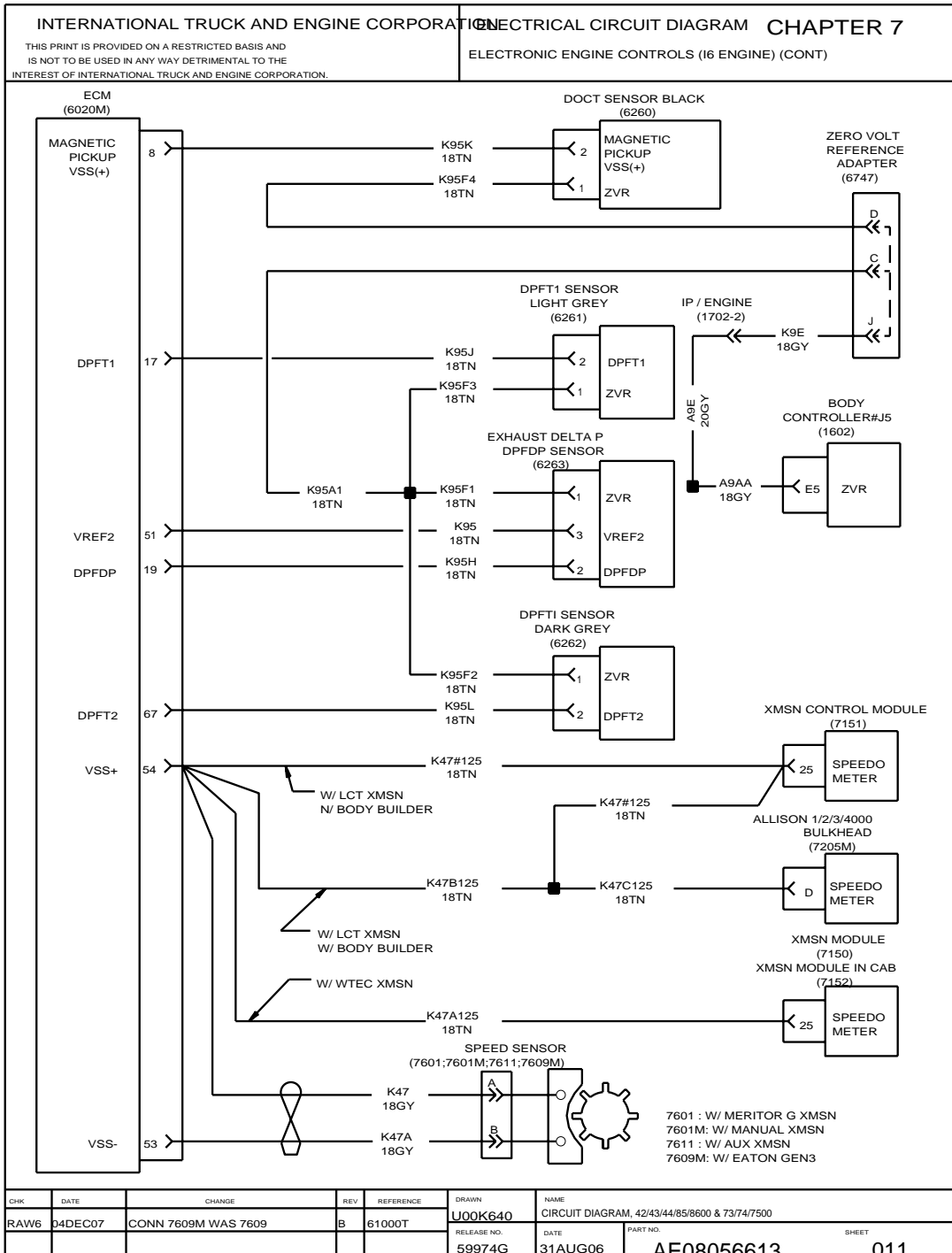

Figure 100 Electronic Engine Controls, I6 Engines (Cont.)

7.12. ELECTRONIC ENGINE CONTROLS — V8 ENGINES, P. 12

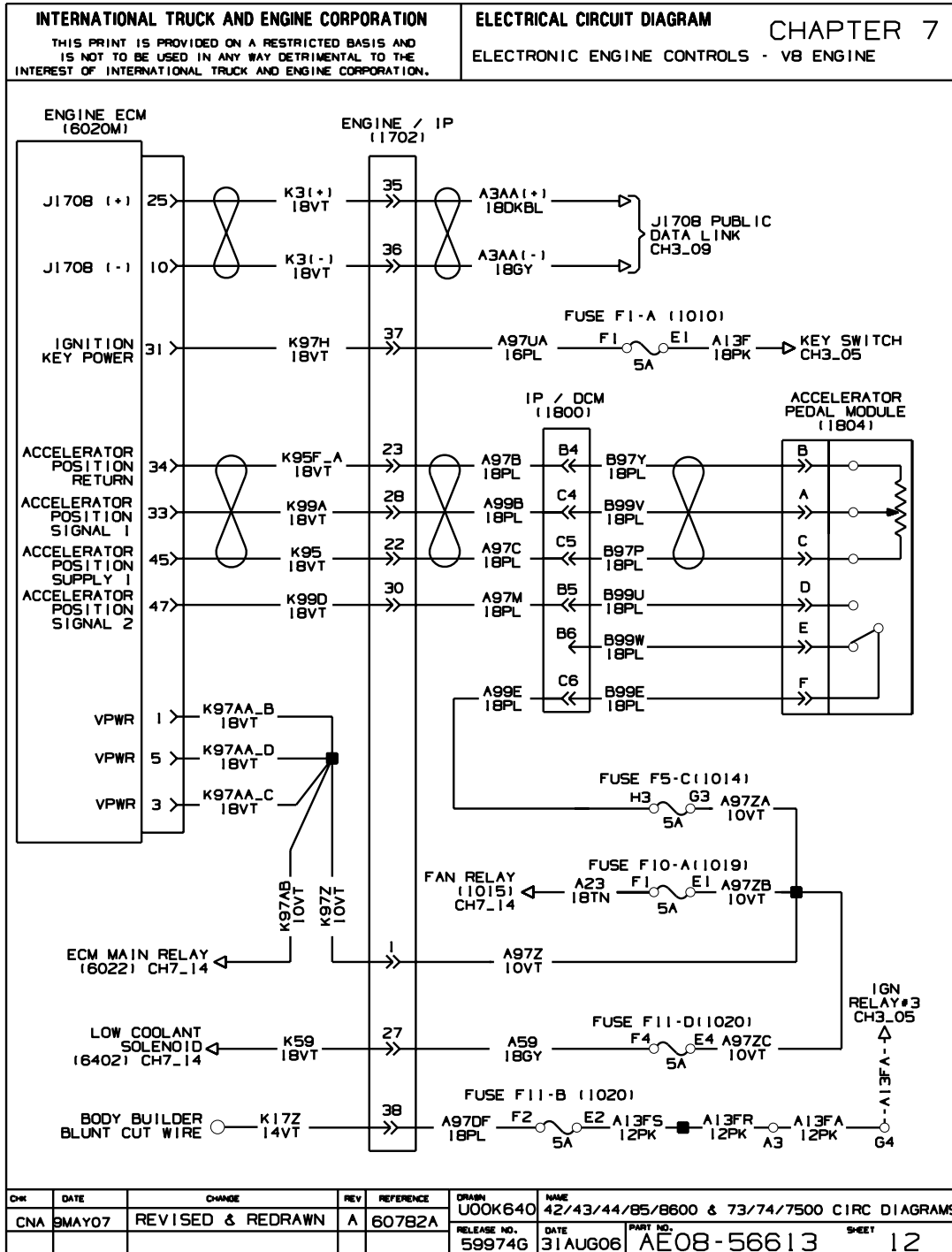

Figure 101 Electronic Engine Controls — V8 Engines

7.13. ELECTRONIC ENGINE CONTROLS — V8 ENGINES, P. 13

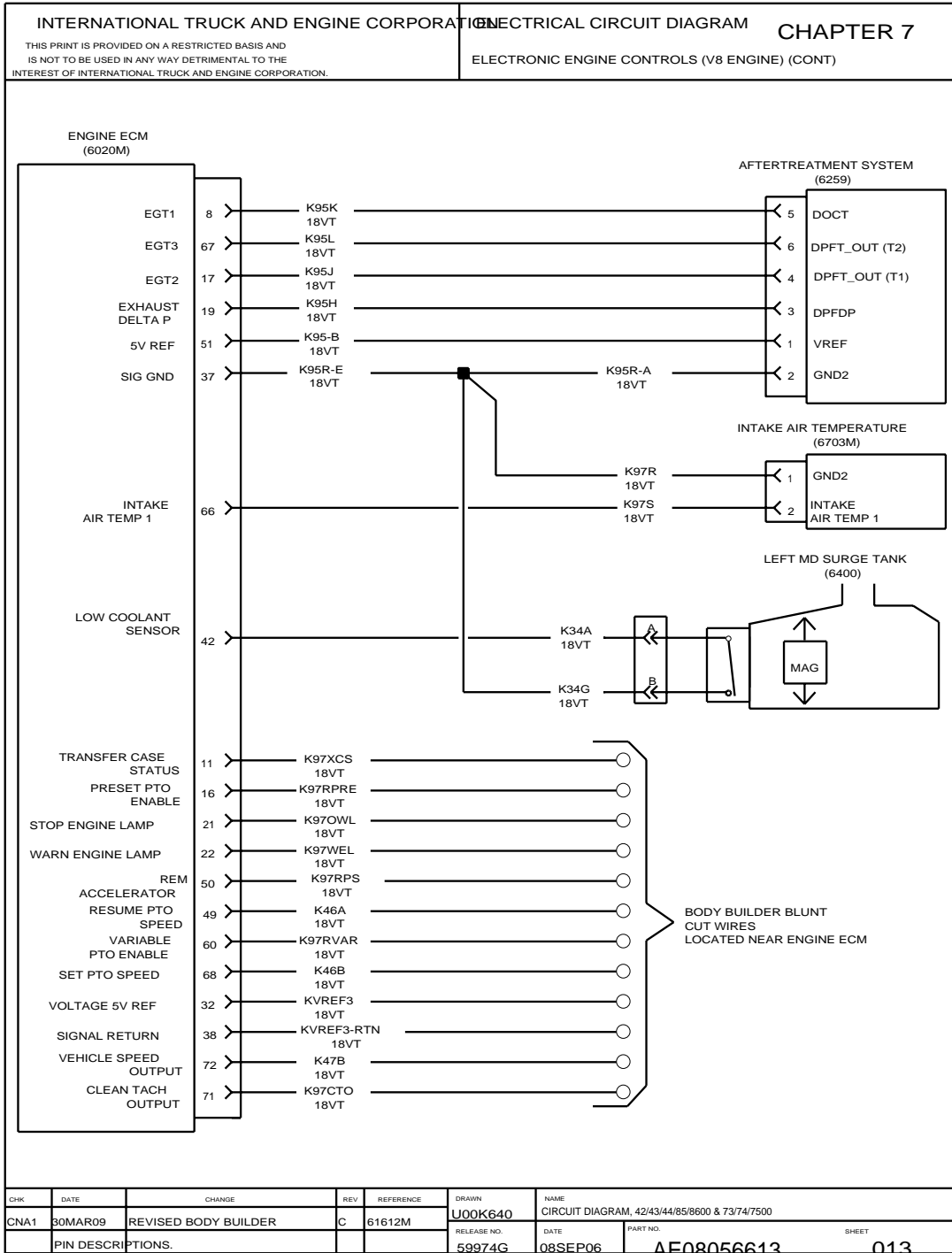

Figure 102 Electronic Engine Controls — V8 Engines

7.14. ELECTRONIC ENGINE CONTROLS — V8 ENGINES, P. 14

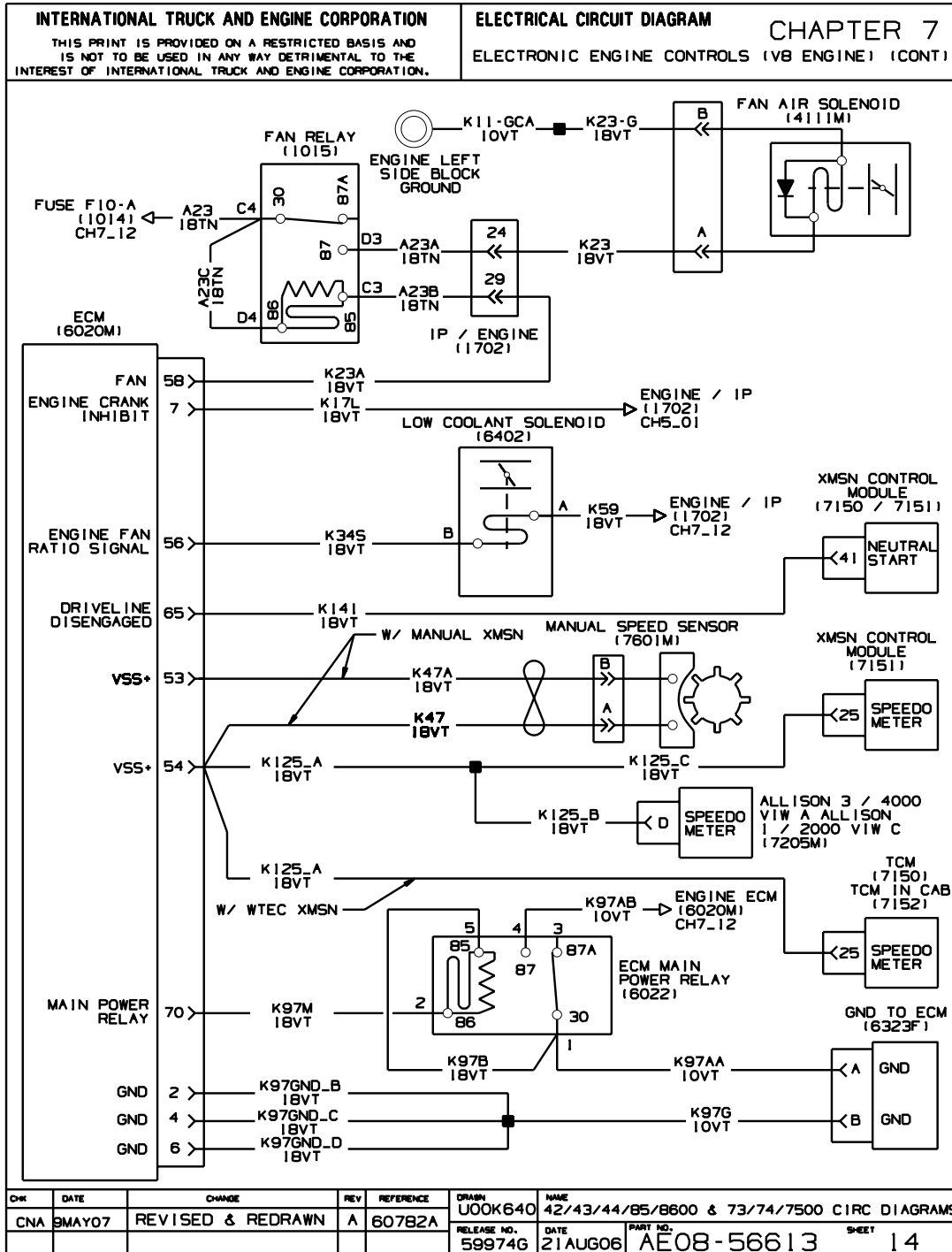

Figure 103 Electronic Engine Controls — V8 Engines

7.15. CRUISE CONTROL, P. 15

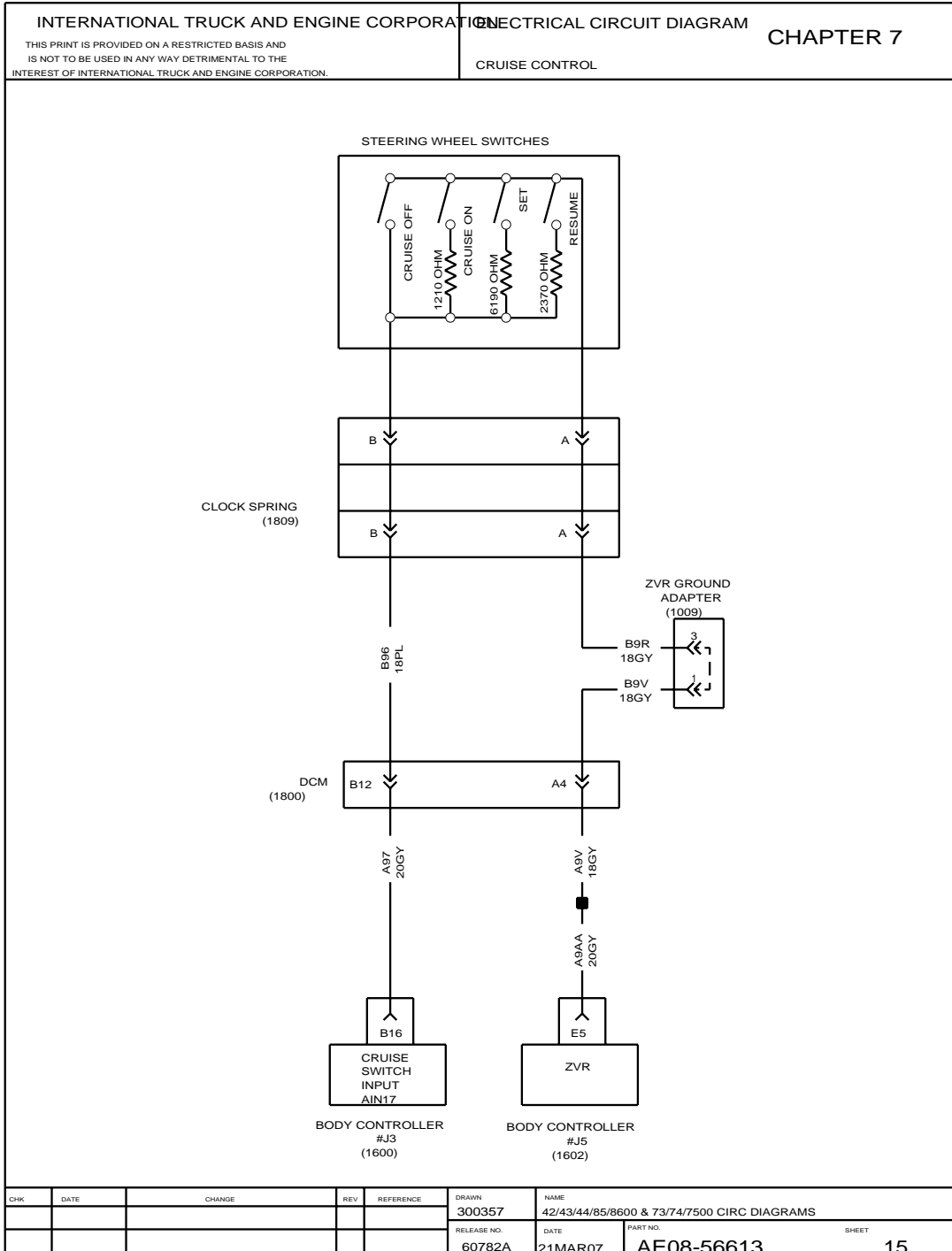

Figure 104 Cruise Control