

SERVICE MANUAL

SERVICE MANUAL SECTION

Bosch Parking Brake: Manual or Power Brake

Vendor: Bosch

Model: 3200

Model: 4200

Model: 4300

Model: 4400

S04044

10/08/2008

Table of Contents

DESCRIPTION.....	1
1. BRAKE SHOE ADJUSTMENT AND INSPECTION.....	1
2. PARK BRAKE CABLE ADJUSTMENT: MANUAL BRAKE	1
3. PARK BRAKE: POWER BRAKE.....	3
3.1. MANUALLY RELEASING POWER PARKING BRAKE.....	4
3.2. ROD STROKE SENSOR: REMOVE	4
3.3. ROD STROKE SENSOR: INSTALL.....	6
3.4. SPRING CHAMBER ASSEMBLY: REMOVE.....	7
3.5. SPRING CHAMBER ASSEMBLY: INSTALL.....	8
SPECIAL SERVICE TOOLS.....	9

DESCRIPTION

This manual addresses the drive-line parking brake. The manual includes information about the actuation of both the manual and power parking brake, brake shoe adjustment of the parking brake both with the drum on and drum off. It also addresses adjustment of the parking brake cable, and the installation and removal of the spring chamber for the air actuated power parking brake.

1. BRAKE SHOE ADJUSTMENT AND INSPECTION

 **WARNING** – To avoid property damage, serious personal injury or possibly death, work on a flat, level surface. Use wheel chocks.

 **WARNING** – To avoid property damage, serious personal injury or possibly death, do not work under or around a vehicle supported by a mechanical or hydraulic jack. Vehicle must be supported by suitable floor stands.

 **WARNING** – Whenever possible, work on brakes in a separate area away from other operations. Always wear a respirator approved by NIOSH or MSHA during all brake service procedures. NEVER use compressed air or dry brushing to clean brake parts or assemblies. OSHA recommends that you use cylinders that enclose the brake. These cylinders have vacuums with high efficiency (HEPA) filters and worker's arm sleeves. But, if such equipment is not available, carefully clean parts and assemblies in the open air.

Clean brake parts and assemblies in the open air. During disassembly, carefully place all parts on the floor to avoid getting dust into the air. Use an industrial vacuum cleaner with a HEPA filter system to clean dust from the brake drums, backing plates and other brake parts. After using the vacuum, remove any remaining dust with a rag soaked in water and wrung until nearly dry.

CAUTION – Keep grease and other foreign materials away from the shoe lining and drum surfaces. Contamination of shoe linings or drum may result in degradation of brake linings.

For complete adjustment and inspection service procedures, go to the Bosch USA website from the ISIS Suppliers listing and refer to the 305 x 76 Park Brake Service Manual.

http://rb-kwin.bosch.com/us//pool/usa/pdfs/Park_Brake_Service_Manual.pdf

2. PARK BRAKE CABLE ADJUSTMENT: MANUAL BRAKE

CAUTION – Do not let the handle snap back when the tool is off the cable. The tool will be damaged.

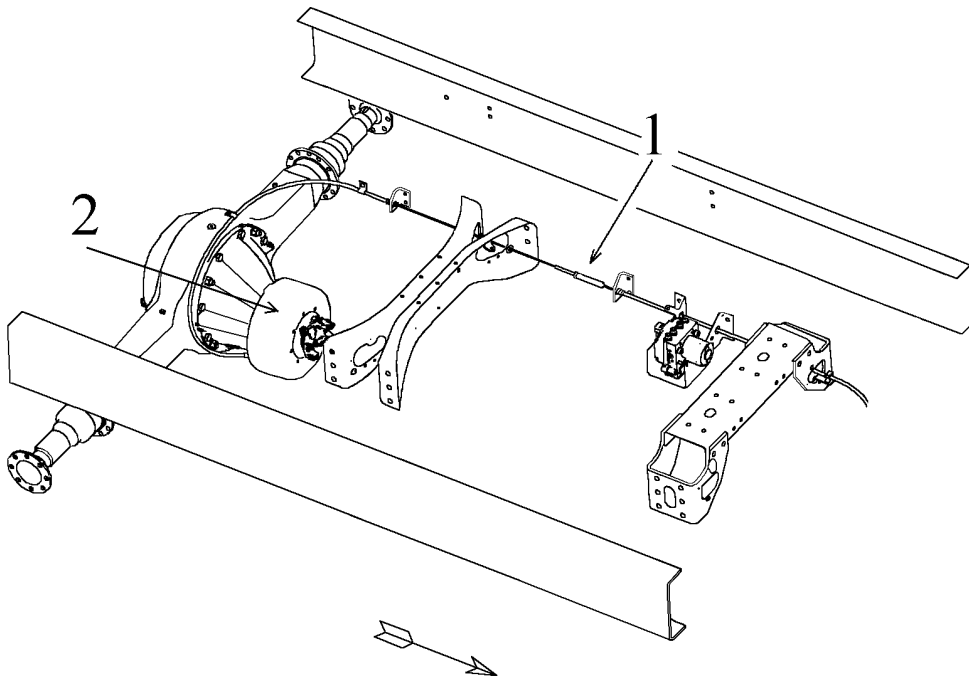

Figure 1 Parking Brake System Overview: Manual Brake

1. BRAKE CABLE ADJUSTMENT TURNBUCKLE
2. PARKING BRAKE

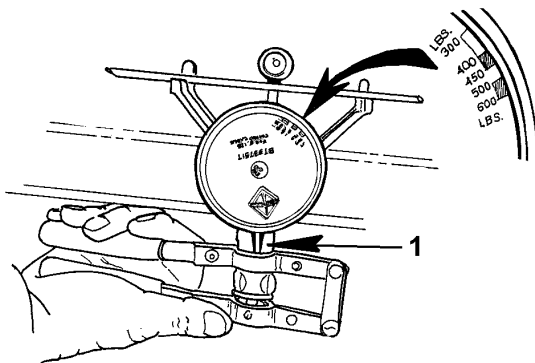

Figure 2 Tension Measuring Tool

1. INDICATING BAR

1. Set parking brake.
2. Locate the park brake cable adjustment turnbuckle in the left frame rail (Figure 1).

NOTE – Check cable tension immediately forward of the turnbuckle (Figure 1).

3. Depress the tool handle fully so that the wheel will engage the far side of the cable (Figure 3).

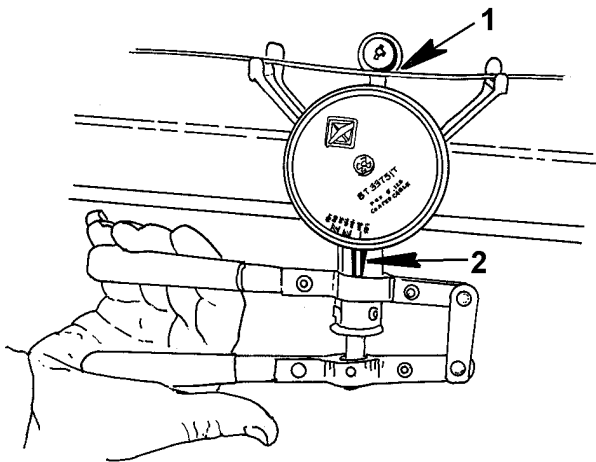

Figure 3 Tension Measuring Tool Handles Depressed

1. WHEEL
2. INDICATING BAR

NOTE – Correct cable tension for adjustment of a new (replacement) cable is 500 ± 25 lb.

NOTE – Correct cable tension for adjustment of existing cable is 390 ± 25 lb.

4. Release the handle quickly but smoothly and read the direct tension units on the dial face next to the indicating bar (Figure 3).

If tension is incorrect, remove tool, release park brake, and re-adjust tension using the park brake cable turnbuckle (Figure 1). Recheck cable tension. Repeat steps 1–4 until tension is within correct limits.

5. Set and release the park brake five times then check tension. If tension is within correct limits the operation is complete. If the tension is not within correct limits repeat steps 1–5.

3. PARK BRAKE: POWER BRAKE

Please review the following general information.

- The air actuated parking brake is equipped with an air gauge and warning light. When the air pressure in the parking brake air storage system has been reduced to approximately 70 psi (483 kPa), the light will activate.
- If air pressure is reduced to approximately 30 psi (207 kPa), the parking brake control knob will automatically pop out and apply the parking brake.
- Upon loss of air pressure, partial parking brake application will occur prior to automatic application of the control valve.
- If the parking brake will not release and the vehicle must be moved, the spring chamber must be manually caged by turning the cable adjustment rod counter-clockwise until the spring is caged in the chamber.

! **WARNING** – To avoid property damage, serious personal injury or possibly death, when manually releasing the spring chamber assembly, be sure to block the wheels so that the vehicle cannot move when the parking brake is released.

! **WARNING** – To avoid property damage, serious personal injury or possibly death, never attempt to disassemble the power park brake spring chamber assembly. This part is not serviceable.

3.1. MANUALLY RELEASING POWER PARKING BRAKE

To manually release the power parking brake follow Step One (1), and Step Four (4) of the instruction section SPRING CHAMBER ASSEMBLY: REMOVE. When the cable adjustment rod is sufficiently un-threaded, tension on the brake cable will be relaxed and the brake will release.

3.2. ROD STROKE SENSOR: REMOVE

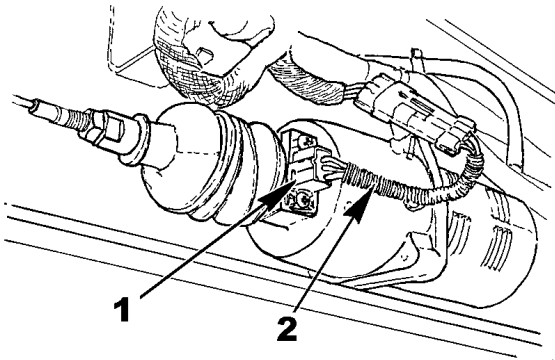

Figure 4 Rod Stroke Sensor Overview

1. ROD STROKE SENSOR
2. SENSOR HARNESS

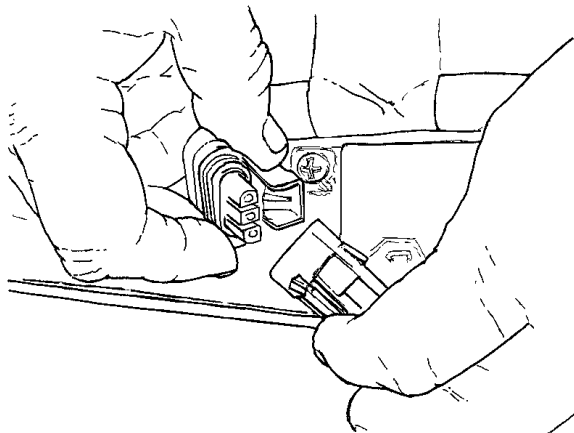

Figure 5 Disconnect Harness

1. Disconnect rod stroke sensor harness (Figure 5).

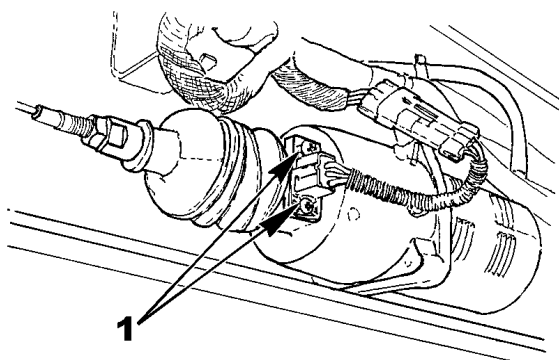

Figure 6 Rod Stroke Sensor Retaining Screws

1. TWO RETAINING SCREWS
2. Remove the two retaining screws (Figure 6).

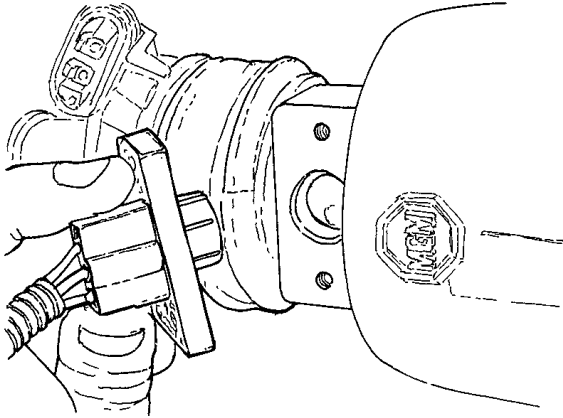

Figure 7 Rod Stroke Sensor

3. Remove rod stroke sensor (Figure 7).

CAUTION – Sensor aperture must be protected from debris. If no appropriate size caps are available, the aperture can be covered with electrical tape, or suitable alternative.

3.3. ROD STROKE SENSOR: INSTALL

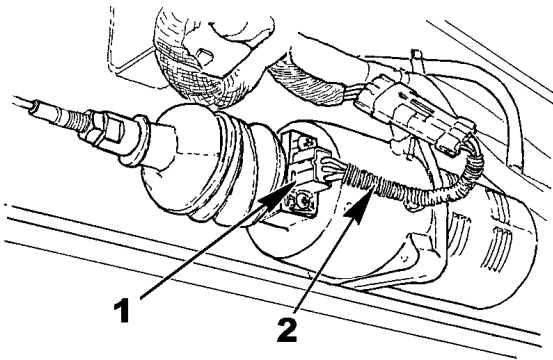

Figure 8 Rod Stroke Sensor and Harness

1. ROD STROKE SENSOR
2. SENSOR HARNESS

1. Connect harness (Figure 8).
2. Install sensor (Figure 7 and Figure 8).
3. Install retaining screws (Figure 6 and Figure 8).

3.4. SPRING CHAMBER ASSEMBLY: REMOVE

1. Dump air from the system with the dash panel park brake knob. Do not bleed the air tank.

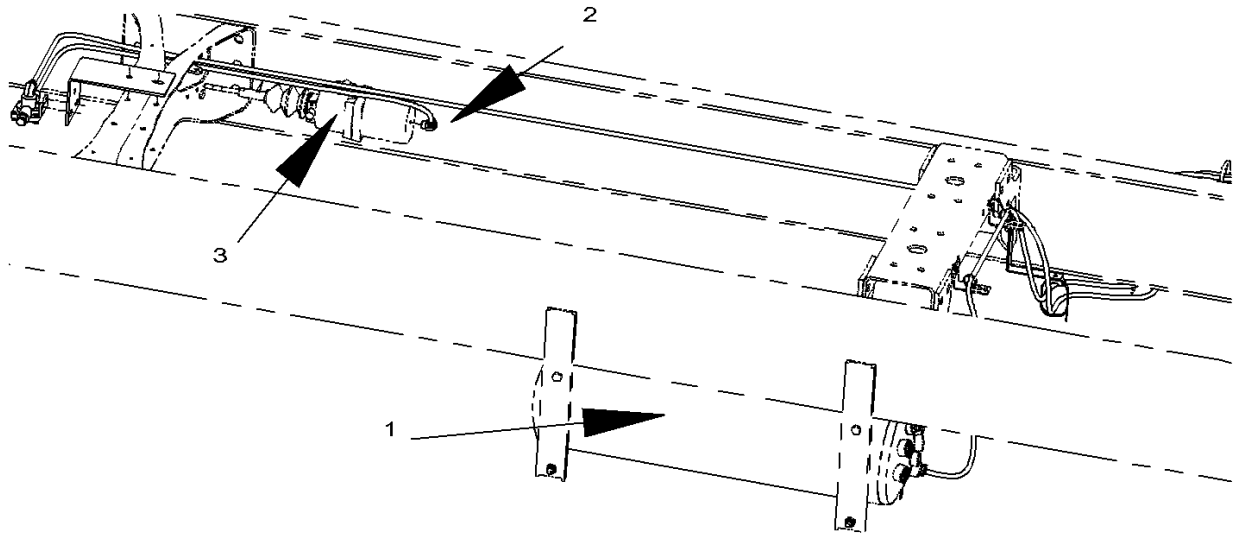

Figure 9 Air Brake Overview

1. AIR TANK
2. AIR LINE
3. SPRING CHAMBER ASSEMBLY

2. Disconnect air line from the spring chamber (Item 3, Figure 9).
3. Disconnect rod stroke sensor wire harnesses (Figure 8).

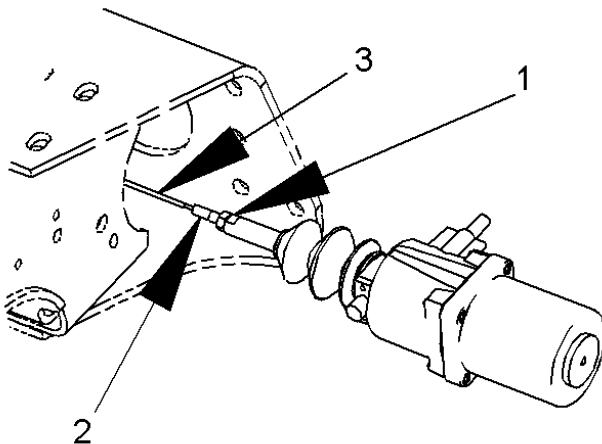

Figure 10 Spring Chamber Assembly

1. JAM NUT
2. CABLE ADJUSTMENT ROD
3. CABLE

- Loosen jam nut and un-thread adjustment rod from chamber to reduce tension on the cable. Continue to un-thread adjustment rod all the way and remove from chamber (Figure 10). **Nut and shaft are metric.**

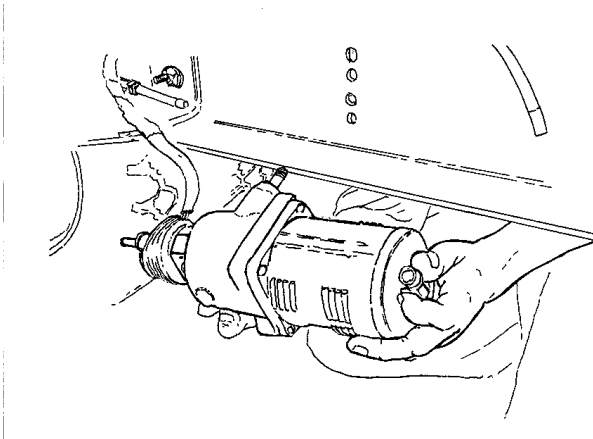

Figure 11 Spring Brake Chamber

- Remove (2) brake chamber mounting nuts from frame rail.
- Remove brake chamber.

3.5. SPRING CHAMBER ASSEMBLY: INSTALL

- If the rod stroke sensor has been removed, install it before installing the spring chamber.
- Start threads of cable adjustment rod before installing the chamber on the frame rail.
- Mount chamber on frame rail. Tighten mounting nuts 55 to 60 lbf-ft. (75 to 81 Nm) of torque.
- Connect stroke sensor harness.
- Reconnect the airline to front of the spring chamber and charge the spring chamber by moving the dash panel park brake knob to the 'out' or released position. This will extend the cable adjustment rod and ease threading the cable.

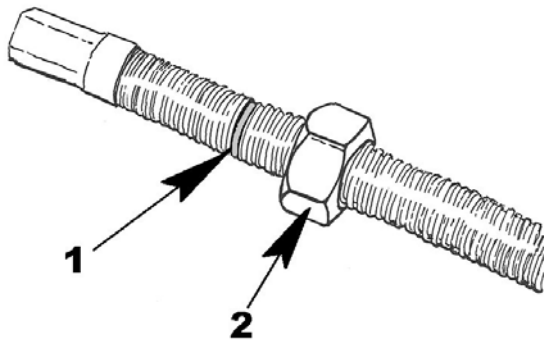

Figure 12 Threaded Adjustment Rod With Groove

- 1. GROOVE ON CABLE ADJUSTMENT ROD
- 2. JAM NUT

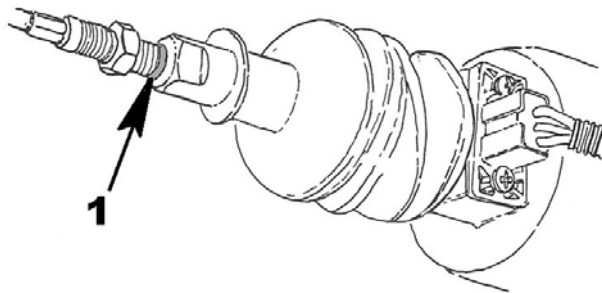

Figure 13 Adjustment Rod With Groove

- 1. GROOVE ALIGNED WITH SHAFT

6. Thread the cable adjustment rod into the cylinder until the groove lines up with the cylinder (Figure 12 and Figure 13).

7. Tighten the jam nut.

SPECIAL SERVICE TOOLS

Table 1

Part Number	Description
ZTSE4569	Parking Brake Cable Tension Gauge